

CONFIDENTIAL

Avery Weigh-Tronix

ZM401/405

Weight Indicators



Service Manual

original instructions

Avery Weigh-Tronix is a trademark of the Illinois Tool Works group of companies whose ultimate parent company is Illinois Tool Works Inc (“Illinois Tool Works”). Copyright © 2018 Illinois Tool Works. All rights reserved.

No part of this publication may be reproduced by making a facsimile copy, by the making of a copy in three dimensions of a two-dimensional work and the making of a copy in two dimensions of a three-dimensional work, stored in any medium by electronic means, or transmitted in any form or by any means, including electronic, mechanical, broadcasting, recording or otherwise without the prior written consent of the copyright owner, under license, or as permitted by law.

This publication was correct at the time of going to print, however Avery Weigh-Tronix reserves the right to alter without notice the specification, design, price or conditions of supply of any product or service at any time.

Table of Contents

	<i>page</i>
Manual revision history	7
Chapter 1 General information and warnings	9
About this manual	9
Text conventions	9
Special messages	9
Installation	10
Torque specifications	10
Proper grounding of cables	10
Panel mount scale interface cable installation	11
Safe handling of equipment with batteries	12
Wet conditions	12
Routine maintenance	12
Cleaning the machine	13
Training	13
Sharp objects	13
FCC and EMC declarations of compliance	13
Chapter 2 Introduction	14
Front panel	14
Front Display	16
Powering up the ZM400	17
Alphanumeric entry procedure (ZM401 only)	17
Using the alphanumeric keypad (ZM405 only)	18
Entering negative numbers or decimal point	18
String index/character data entry	18
Chapter 3 Introduction to the menus	20
Accessing the menus	21
Exiting the menus	21
Menu annunciators	22
Quick Code parameter entry	23
Chapter 4 User level menus	24
User menu	24
Time	25
Date	25
Site ID	26
Seal	26
Archive	26
About menu	27
Boot (Bootloader)	28
Firmware	28
App	28
Serial	28
Option	29
Enet	29
Download	30
BSQ	30
Audit menu	31
Counter	31
Print	32

Chapter 5 Diagnostics level menus	33
Diag menu	33
Scale	34
Current Zero	34
Display	35
Buttons	35
Ports	35
Inputs	36
Outputs	36
Options	37
Logs	37
BSQ	38
Chapter 6 ADMIN level menus	39
Setup menu	39
Calibration Procedure	40
Scale 1-2	40
Zero Procedure	41
Span Procedure	42
Linearity Procedure	42
Input procedure	43
Gravity Factor Procedure	44
Display	45
Calibration Unit	45
Print calibration report	45
Scale	46
Scale 1-2	47
Capacity	47
Division	47
Units	48
Stable	49
AZT	49
Filter	50
Ranges	51
2,3,Range	52
Type	53
ROC	54
System	55
Default Values	56
Site	57
Display	57
Buttons	58
Display values	58
Tare	61
Config	62
Archive	62
Serial	63
Update	63
Password	64
Z-Lock	64
Beeper	65
Number of Scales	65
Ports	66
Serial	67
Ethernet	68
Protocol	71
P.F.Edit	74

PLC	74
Printer	76
File	77
Options	79
Chapter 7 Communication port protocols	82
SMA Protocol	82
Level 1 and 2 Commands	82
Standard Scale Response Message	83
Unrecognized Command Response	83
About Command Response	83
Scale Information Command Response	84
Avery Weigh-Tronix Extended SMA Commands	85
ENQ & B-Cast commands	87
NCI commands	88
R-Disp commands	89
PLC Configuration information	90
ModBus/TCP	90
Ethernet/IP Implicit Messaging:	92
Ethernet/IP Explicit Messaging:	92
Chapter 8 Option cards	93
Analog output card	94
Current Loop/RS485/RS422 card	95
USB Device option card	96
Wireless Ethernet communication (802.11g) card	97
Internal 120 VAC relay card (for IP69K only)	98
Specifications	98
Installing the option card	99
2nd Scale Input 5VDC Excitation card	100
2nd Scale Input 10 VDC Excitation w/STVS card	101
External I/O Interface card	102
AC input, 4 Inputs (120-240VAC) card	103
DC input, 4 inputs(4-30VDC) card	104
AC output, 4 relays (20-240VAC) card	105
DC output, 4 relays (3-60VDC) card	106
Chapter 9 Printed reports	107
Configuration report	107
Calibration report	107
Audit report	108
Chapter 10 Print formatting	109
Print Format Editor	109
Editing an existing print string	110
Inserting characters	111
Deleting characters	112
Inserting tokens, etc.	114
Other scale tokens	116
Transmitting leading zeroes	117
Print format errors	118
Chapter 11 Print tokens, parameters and default print formats	119
Notes on width syntax	119
Explanation of width syntax for WEIGHT (integers)	119
Explanation of width syntax for WEIGHT (strings)	119
Explanation of width syntax for UNITS OF MEASURE (strings)	119
Firmware tokens	120

Additional token tables	126
Network tokens	127
ASCII characters	129
Control codes	130
Default print formats	131
Chapter 12 Complete menu structures	133
Chapter 13 Technical illustrations	139
Stainless steel enclosure assembly	139
Stainless steel enclosure parts kits	140
Panel mount enclosure parts and assembly	141
Panel mount enclosure parts lists	142
System block diagram	143
ZM jumper and switch settings	144
ZM remote inputs and outputs, Opto-22 module	145
STVS (Severe Transient Voltage Suppressor) installation	146
Outline dimensions (stainless steel)	147
Outline dimensions (panel mount)	148
Panel mount assembly	149
D-cell Battery pack option (AWT05-505852) and external battery circuitry	150
Keypad overlay replacement procedure	151
To change the keypad you will need these tools:	151
Process to remove and replace the keypad overlay	151
Index	153

Manual revision history

Current Issue	Date Created	Details of Changes
AA	Sept. 2015	New manual
AB	June 2016	Changed file name and title. Fixes to section 7.5.3. Correction to 13.6 title. Fixed index error. Updated to new firmware level. Updated diagrams on page 104. Fixed error in section 8.8.
AC	May 2018	Fixed a PN on page 140. Waiting for more changes before releasing. Removed incorrect item # from common parts list on page 140. Fixed 7.5.1.
AD	October 2023	Updated part numbers for Main Board and Gasket Kit.
AE	November 2023	Added in Panel Mount Bracket Kit information.

1 General information and warnings

1.1 About this manual

This manual is divided into chapters by the chapter number and the large text at the top of a page. Subsections are labeled using the 1.1 and 1.1.1 convention. The names of the chapter and the next subsection level appear at the top of alternating pages of the manual to remind you of where you are in the manual. The manual name and page numbers appear at the bottom of the pages.

1.1.1 Text conventions

Key names are shown in **bold** and reflect the case of the key being described. If a key has dual functions, the function is shown first followed by the key name in parentheses and in bold, such as in these examples: **F1, SELECT, PRINT**, etc.

Displayed messages appear in ***bold italic*** type and reflect the case of the displayed message.

1.1.2 Special messages

Examples of special messages you will see in this manual are defined below. The heading words have specific meanings to alert you to additional information or the relative level of hazard.



ELECTRICAL WARNING!
THIS IS AN ELECTRICAL WARNING SYMBOL.
ELECTRICAL WARNINGS MEAN THAT FAILURE TO FOLLOW SPECIFIC PRACTICES OR PROCEDURES MAY RESULT IN ELECTROCUTION, ARC BURNS, EXPLOSIONS OR OTHER HAZARDS THAT MAY CAUSE INJURY OR DEATH.



WARNING!
This is a Warning symbol.
Warnings mean that failure to follow specific practices and procedures may have major consequences such as injury or death.



CAUTION!
This is a Caution symbol.
Cautions give information about procedures that, if not observed, could result in damage to equipment or corruption to and loss of data.



NOTE: This is a Note symbol. Notes give additional and important information, hints and tips that help you to use your product.

1.2 Installation



NO USER SERVICEABLE PARTS. REFER TO QUALIFIED SERVICE PERSONNEL FOR SERVICE.

1.2.1 Torque specifications



CAUTION: The acorn nuts holding the back plate of the indicator in place must each be tightened, in multiple passes, in the following pattern to a final torque of 0.68 N-m (approximately 6 in-lbs) to ensure proper gasket sealing.

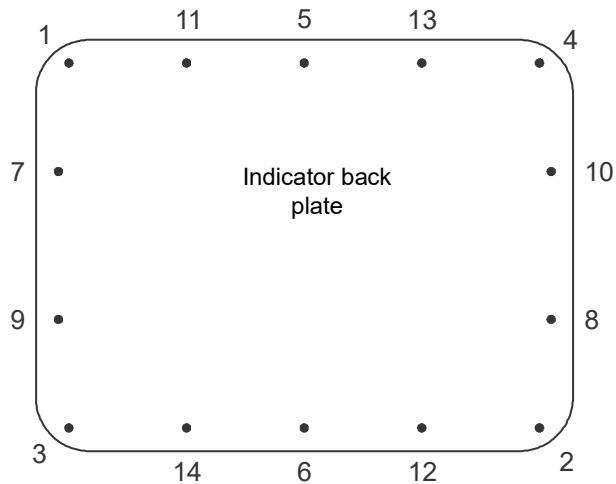

There are four sizes of strain reliefs exiting the indicator: PG11, PG7, PG13.5 and NPT 3/4". The torque specifications for the locknuts which hold the strain reliefs to the indicator housing and the specs for the dome nuts which seal the cable that passes through the strain relief are shown in the table below.

	3/4" NPT Strain Relief	PG13.5 Strain Relief	PG11 Strain Relief	PG7 Strain Relief
Dome Nut	66.4 lb-in 7.5 N-m	33.2 lb-in 3.75 N-m	33.2 lb-in 3.75 N-m	22.1 lb-in 2.5 N-m
Lock Nut	44.2 lb-in 5 N-m	22.1 lb-in 2.5 N-m	22.1 lb-in 2.5 N-m	14.4 lb-in 1.62 N-m

1.2.2 Proper grounding of cables

On the stainless steel desktop models, cable shield wires should be grounded directly to the studs provided at the bottom of the enclosure, close to the strain relief entry point, with wire lengths at a minimum. On the aluminum and panel mount models the shield wires should be connected to the SHLD connection on the corresponding terminal block connectors.

1.2.3 Panel mount scale interface cable installation

The ZM401 & ZM405 Panel Mount assemblies include the AWT25-501388 Ferrite. Installing the Ferrite on the Scale Interface Cable on the Panel Mount models assists with eliminating potential noise captured by the scale interface cable.

Attach the ferrite onto the scale interface cable by wrapping the unshielded wires once around the ferrite as shown below. Leave the Shield drain wire outside the ferrite and connect to the SHLD connection on the terminal block, as shown in the photos below.

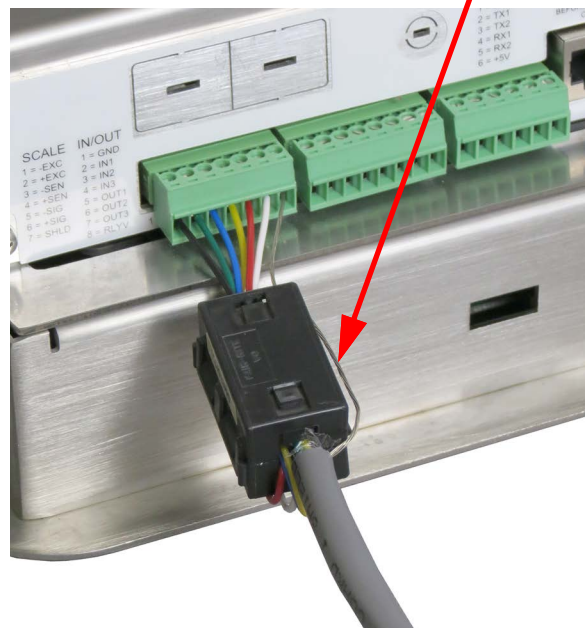
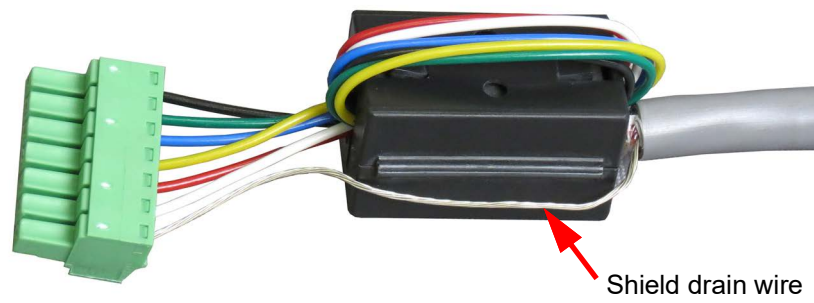

The optional 2nd Scale Input 5VDC & 10VDC Excitation Modules also include the AWT25-501388 Ferrite for use on the ZM401 & ZM405 Panel Mount Models. The Ferrites are not needed on the stainless steel desktop models as the Shield of the Scale Interface cable terminates directly to the studs on the bottom of the enclosure.

1.2.4 Safe handling of equipment with batteries



CAUTION: *Danger of explosion if battery is incorrectly replaced. Replace only with the same or equivalent type recommended by the manufacturer. Dispose of used batteries according to the manufacturer's instructions.*

ATTENTION: *Il y a danger d'explosion s'il y a remplacement incorrect de la batterie, remplacer uniquement avec une batterie du même type ou d'un type équivalent recommandé par le constructeur. Mettre au rebut les batteries usagées conformément aux instructions du fabricant.*

1.2.5 Wet conditions

Under wet conditions, the plug must be connected to the final branch circuit via an appropriate socket / receptacle designed for washdown use.

Installations within the USA should use a cover that meets NEMA 3R specifications as required by the National Electrical Code under section 410-57. This allows the unit to be plugged in with a rain tight cover fitted over the plug.

Installations within Europe must use a socket which provides a minimum of IP56 protection to the plug / cable assembly. Care must be taken to make sure that the degree of protection provided by the socket is suitable for the environment.

1.3 Routine maintenance



IMPORTANT: *This equipment must be routinely checked for proper operation and calibration. Application and usage will determine the frequency of calibration required for safe operation.*

Always turn off the machine and isolate from the power supply before starting any routine maintenance to avoid the possibility of electric shock.

1.4 Cleaning the machine

Table 1.1 Cleaning DOs and DON'Ts



DO	DO NOT
Wipe down the outside of standard products with a clean cloth, moistened with water and a small amount of mild detergent	Attempt to clean the inside of the machine
	Use harsh abrasives, solvents, scouring cleaners or alkaline cleaning solutions
Spray the cloth when using a proprietary cleaning fluid	Spray any liquid directly on to the display windows

1.5 Training

Do not attempt to operate or complete any procedure on a machine unless you have received the appropriate training or read the instruction books.

To avoid the risk of RSI (Repetitive Strain Injury), place the machine on a surface which is ergonomically satisfactory to the user. Take frequent breaks during prolonged usage.

1.6 Sharp objects

Do not use sharp objects such as screwdrivers to operate the keys.

1.7 FCC and EMC declarations of compliance

United States

This equipment has been tested and found to comply with the limits for a Class A digital device, pursuant to Part 15 of the FCC Rules. These limits are designed to provide reasonable protection against harmful interference when the equipment is operated in a commercial environment. This equipment generates, uses, and can radiate radio frequency energy and, if not installed and used in accordance with the instruction manual, may cause harmful interference to radio communications. Operation of this equipment in a residential area is likely to cause harmful interference in which case the user will be required to correct the interference at his own expense.

Canada

This digital apparatus does not exceed the Class A limits for radio noise emissions from digital apparatus set out in the Radio Interference Regulations of the Canadian Department of Communications.

Le présent appareil numérique n'émet pas de bruits radioélectriques dépassant les limites applicables aux appareils numériques de la Classe A prescrites dans le Règlement sur le brouillage radioélectrique édicté par le ministère des Communications du Canada.

European Countries

WARNING: This is a Class A product. In a domestic environment, this product may cause radio interference in which the user may be required to take adequate measures.

2 Introduction

This manual covers the installation, connections, configuration and servicing of the ZM400 series indicators, shown in [Figure 2.1](#). The ZM401 and ZM405 come in stainless steel panel mount and desktop models. The ZM400 indicator will support up to two scales with a maximum total of 16 x 350 ohm load cells. The standard indicator can connect to a single analog scale, an analog and digital scale or two digital scales. With an option card they can support 2 analog scale inputs. The standard indicator connectivity includes a USB Host, two RS232 ports and an Ethernet port. The following internal module cards are available as options:

- 1 Analog Output
- 1 Current Loop/RS485/RS422
- 1 USB Device
- 1 Wireless 802.11g
- 1 Internal 120 VAC relay
- 1 2nd Scale Input 5VDC Excitation
- 1 2nd Scale Input 10 VDC Excitation
- 1 External I/O Interface (for existing GSE or 1310 I/O cards)
- 1 AC input, 4 Inputs (120-240VAC)
- 1 DC input, 4 inputs (4-30VDC)
- 1 AC output, 4 relays (20-240VAC)
- 1 DC output, 4 relays (3-60VDC)

The indicators also have three logic level inputs with configurable functions and three set point outputs and can interface with remote analog or digital scales, PLC's and scoreboards. See the Specification literature for a full list of specifications.



Figure 2.1 Front panels of the ZM401 and ZM405 indicators

The ZM400 can connect to USB flash drives, printers, remote displays, computers and other peripheral devices.







2.1 Front panel

The front panels for the ZM400 series are shown in [Figure 2.1](#) and consists of the keys and the display.















Never press a key with anything but your finger. Damage to the overlay may result if sharp or rough objects are used.

The normal function of the keys on the front panel of the ZM401 are listed below.

	Press the TARE key to perform a pushbutton tare function. Acts as an up arrow key for menu navigation. Allows entry of numeric values.
	Press the SELECT key to toggle between the active display values. Press and hold to enter the setpoint editor. Acts as a down arrow key for menu navigation. Allows entry of numeric values.
	Press the ZERO key to zero the display. Acts as an ENTER key to accept a displayed value or function.
	Press the PRINT key to send information to a peripheral device through a configured communications port. Acts as a left arrow key for menu navigation and removes last digit during numeric entry.
	Press the UNITS key to scroll through the available units of measure while in normal operating mode. Acts as a right arrow key for menu navigation and inserts new digit during numeric entry.
	Press the F1 key to select application specific choices. Aborts a numeric entry and acts as an ESCAPE key in the menu navigation. Press and hold to view the password entry screen for menu access.

The normal function of the keys on the front panel of the ZM405 are listed below.

	Press the TARE key for pushbutton, key entry or preset Tare functions. Acts as an up arrow key for menu navigation. Allows entry of numeric values.
	Press the SELECT key to toggle between the active display values. Press and hold to enter the setpoint editor. Acts as a down arrow key for menu navigation. Allows entry of numeric values.
	Press the PRINT key to send information to a peripheral device through a configured communications port. Acts as a left arrow key for menu navigation and removes last digit during numeric entry.
	Press the UNITS key to scroll through the available units of measure while in normal operating mode. Acts as a right arrow key for menu navigation and inserts new digit during numeric entry.
	Press the ZERO key to zero the display. Acts as an ENTER key to accept a displayed value or function.
	The SAMPLE key can be used to perform custom application functions.
	The START key can be used to perform custom application functions.

	<p>The STOP key can be used to perform custom application functions.</p>
	<p>The F1/ID key can be used to perform custom application functions. It can also be used to abort a numeric entry and it acts as an ESCAPE key in the menu navigation.</p>
	<p>The SCALE key can be used to perform custom application functions. It can also be used to select the active scale when more than one scale is enabled.</p>
	<p>The SETUP key can be used to perform custom application functions. It can also be used to view the password entry screen for menu access.</p>
	<p>The TARGET key can be used to perform custom application functions.</p>
	<p>Use the numeric keypad to enter numbers in the appropriate screens. Press the C (CLEAR) key to clear the last entry.</p>

2.1.1 Front Display

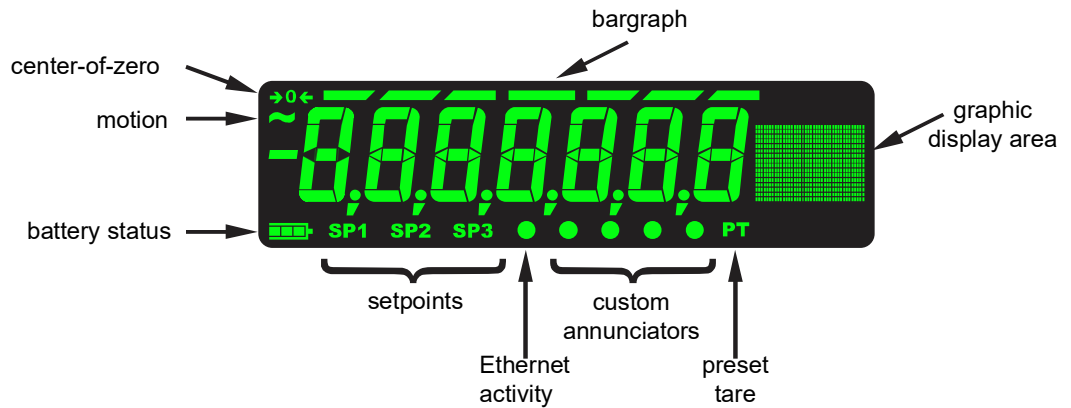

2.2 Powering up the ZM400

The indicator is always active as long as power is received. Power can be supplied by:

- 1 AC power cord connected to a properly grounded outlet (100 VAC - 240 VAC, 50 or 60 Hz)
- 1 External 12VDC @ 1.2 Amps up to 36VDC @400mA (14.4 Watts). These are the power requirements for a fully loaded unit (16 x 350 load cell, 500mA out the 5V COM port terminal block, 500mA load on USB Host, and Wireless option card installed).
- 1 AC to 24VDC power converter (optional accessory for panel mount version)
- 1 Optional external battery pack with 4 D cells:
 - 1 x 350 ohm load cell = 6 hours battery life
 - 4 x 350 ohm load cell = 4 hours battery life
 - 8 x 350 ohm load cell = 1 hour battery life
 (See [D-cell Battery pack option \(AWT05-505852\)](#) and [external battery circuitry on page 150](#) for more information.)

2.3 Alphanumeric entry procedure (ZM401 only)

The keys in [Figure 2.2](#) have alternate functions in alphanumeric entry screens.

	These segments flash in alphanumeric entry mode
TARE / ▲ -	Press to increment the flashing number
SELECT / ▼ -	Press to decrement the flashing number
PRINT / ◀ -	Press to backspace cursor in a number
UNITS / ▶ -	Press to advance cursor in a number
ZERO / ↵ -	Press to accept a value
F1 / ESC -	Press to escape an entry screen

Figure 2.2 Key function during numeric entry



*When the graphic display is present you can scroll through numbers, alpha characters and symbols by repeatedly pressing the **TARE** or **SELECT** keys.*

Use the keys, as described in [Figure 2.2](#), to enter an alphanumeric value on the display. For alphanumeric menu entries the graphics display will only show the last six characters entered. Following is an example:

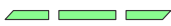
Example: To key in ZM4:

Repeatedly press the **TARE(▲)** or **SELECT(▼)** key until **Z** appears on the display.

Press the **UNITS(→)** key once to move cursor one space to the right.

Repeatedly press the **TARE(▲)** or **SELECT(▼)** key until **M** appears on the display.

Press the **UNITS(→)** key once to move cursor one space to the right.

Repeatedly press the **TARE(▲)** or **SELECT(▼)** key until **4** appears on the display.

Press the **ZERO** key to enter or accept the value.

Press the **PRINT(◀)** key to move the entry function one digit to the left. This effectively deletes the current value in that position and allows you to enter a new value in that position.

2.4 Using the alphanumeric keypad (ZM405 only)

Use the alphanumeric keypad to enter numbers and words when prompted by the indicator. For alphanumeric menu entries the graphics display will only show the last six characters entered.

The action is similar to using a cell phone to select the number or letter. A rapid succession of presses will scroll through the number on the key and then the letters, starting with upper case and then lower case. The decimal key scrolls through the negative sign, pound sign, colon, comma and percent sign. The **0** key toggles between 0 and a space.

2.5 Entering negative numbers or decimal point

To enter a minus sign for a negative number or a decimal point (or comma), press the **C** key (or **PRINT** key) to clear the current value from the display.

Then to enter a negative number, with a single **0** displayed press **SELECT**. The first character will then change to a (-) negative sign. Enter the rest of the digits normally.

To enter a decimal point (or comma), on a ZM405 use the decimal point key. On a ZM401 when the flashing digit is a 0 press the **SELECT** key and a decimal point (or comma) will appear. Then press the **UNITS** key to scroll in the next digit to follow the decimal and enter the rest of the digits normally. To enter a value less than 1 requires the entry of the leading 0 before a decimal point is allowed.

2.6 String index/character data entry

Below are guidelines to create or edit text and scale information for print formats. This is a sample of a string entry display.

When these segments are flashing, you are in the string index select mode. In this mode you select the index character you want to edit or add/delete a character.

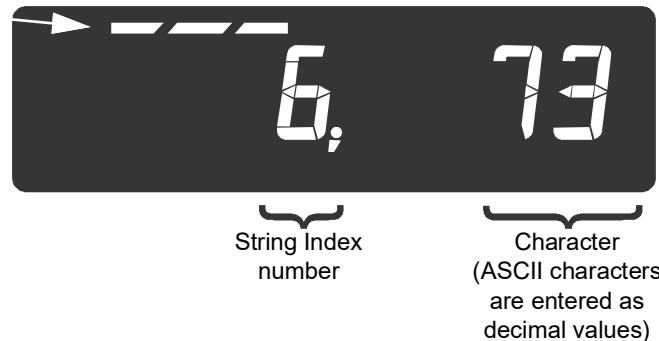

Left-flashing bar graph segments indicate you are in the String Index select mode. Use the Table 1 key legend to:

- 1 move to the index number you want to edit
- 1 add a new index number

- 1 delete an existing index number.

Table 1: Key Action When In The String Index Select Mode						
Action	TARE	SELECT	ZERO	PRINT	UNITS	F1
Momentary Key Press	Deletes current character	Selects the index character for editing using the key actions in Table 2	EXIT	Moves left one position in the index	Moves right one position in the index	Escape Edit mode and Abort all changes
Long Key Press	Deletes current character	Inserts new character before this point. Default character added is 32 (space)	EXIT	Page Up (Decrements index by 10)	Page Down (Increments index by 10)	Escape Edit mode and Abort all changes

- 1 After you select the index number, use the Table 2 key actions to edit the character for that index number.

Table 2: Key Action When In The Character Edit Mode						
Action	TARE	SELECT	ZERO	PRINT	UNITS	F1
Single Key Press	Increments the flashing digit by 1	Decrements the flashing digit by 1	Enter	Delete flashing digit	Add Digit	ESC/Abort
Long Key Press	Move flashing digit left	Move flashing digit right	Enter	Delete the entire entry	Does nothing	ESC/Abort

3 Introduction to the menus

Menus, accessed through passwords, are available in the indicator to customize and configure the indicator for your purposes. The menu levels and their passwords are shown below:

Password	Menu Level	Accessed Menus
111	USER	User, About, Audit
3570	DIAGNOSTICS	Diag, User, About, Audit
3088	ADMIN	Setup, Diag, User, About, Audit
2580	CALIBRATE	Calib
1793	SUPER	Application specific items. See User manual.



The CALIBRATE menu level accesses the calibration procedure only. You can also access the calibration menu through the Setup menu using the ADMIN password.

Some menus appear in more than one menu level. As you can see in the table above, the 111 password gives you access to three menus; User, About and Audit. The 3570 password gives you access to those three plus the Diagnostics menu. The 3088 password gives you access to those four plus the Setup menu.

This allows the supervisor to control access to some or all of the menus based on the passwords shared. The menus are the same no matter which menu level you access them from.



The menus are always explained in a sequential manner to cover all information in a logical fashion. You will probably never access all the menu items in this manner. You can navigate to the area of the menu that needs to be changed by using the menu maps and key navigation legends which are inserted as a reminder with most menus.

See [Alphanumeric entry procedure \(ZM401 only\) on page 17](#) for instructions on how to enter a password to get to the menus. Key functions in the menus are shown below.

Menu Navigation Keys:

Press SELECT/ ▼ to move down in a menu
Press TARE/ ▲ to move up in a menu, except at the bottom item in a menu, then use ZERO/ ↵ or F1
Press PRINT/ ◀ to move left in a menu
Press UNITS/ ▶ to move right in a menu
Press ZERO/ ↵ to accept a value or choice and move up in the menu.
Press F1 to escape and move up in the menu

3.1 Accessing the menus

Follow these steps to access the various menus in the indicator.

1. With the indicator powered up and in normal operating mode, press and hold the **SETUP** key ...

Pass is briefly displayed, then a flashing **0**, prompting you to enter the password.



*When the **0** is flashing, press **F1** and the application name is briefly displayed, then the indicator returns to normal operating mode.*

2. Key in the password for the menu you want to access and press the **ZERO** key to accept it ...

The first item in the top level of the menu you accessed is displayed.

3. Use the navigation keys, shown below, to navigate through the menu structure. The symbols appear on the bottom of the keys.

Menu Navigation Keys:

Press **SELECT**/ ▼ to move down in a menu

Press **TARE**/ ▲ to move up in a menu, except at the bottom item in a menu, then use **ZERO**/ ↵ or **F1**

Press **PRINT**/ ◀ to move left in a menu

Press **UNITS**/ ▶ to move right in a menu

Press **ZERO**/ ↵ to accept a value or choice and move up in the menu.

Press **F1** to escape and move up in the menu

3.2 Exiting the menus

1. If you are at the bottom item in a menu use **ZERO** to accept a choice or value and move up a level, or use **F1** to escape and move up one level without accepting the choice or value. From that point, press the **TARE** key repeatedly until ...

SAVE no is displayed. This means “Do not save changes. “

2. Use the **PRINT** or **UNITS** key to scroll through the choices: **SAVE no**, **SAVEYES** and **CAnCEL**. Press **ZERO** to accept the displayed choice.

If you choose **SAVE no** or **SAVEYES** the indicator exits the menu and returns to normal weighing mode.

OR

If you choose **CAnCEL**, the indicator remains in the menu.

3.3 Menu annunciators

The menu structure is made up of menu items, parameters, value entry screens and lists from which you choose one item. To help you know where you are in the menu, the bar graph at the top of the display is on while the indicator is in the menus and will change appearance according to the following rules:

All segments flashing

This means you are in the menu structure but not in any of the following screens.



Center flashing / others off

This means you are in a numeric entry screen or the Quick Code prompt screen. See [Quick Code parameter entry on page 23](#). Enter a number and press **ZERO** to accept.



Right flashing / others off

This means you are in a list. Scroll through the choices with the **PRINT** and **UNITS** keys and press **ZERO** to accept.



Left flashing / others off

This means you are in a data entry. See [String index/character data entry on page 18](#) for more information.



Every alternate segment flashing

This means you are in octet entry for IP, Subnet or Gateway address.



3.4 Quick Code parameter entry

The Quick Code parameter entry lets you quickly jump to sections of the menu. Here's how it works:

1. Access the 3088 ADMIN menu. Press and hold the **ZERO** key for one second. When you release the key ...

P- 0 is displayed and the three center bargraph segments flash.

2. Refer to the Quick Code table in [Figure 3.1](#), find the parameter you want to access, key in that number and press **ZERO** ...

The screen will show the associated menu item.

3. Use the normal procedures to set the menu item and to save the changes you make.

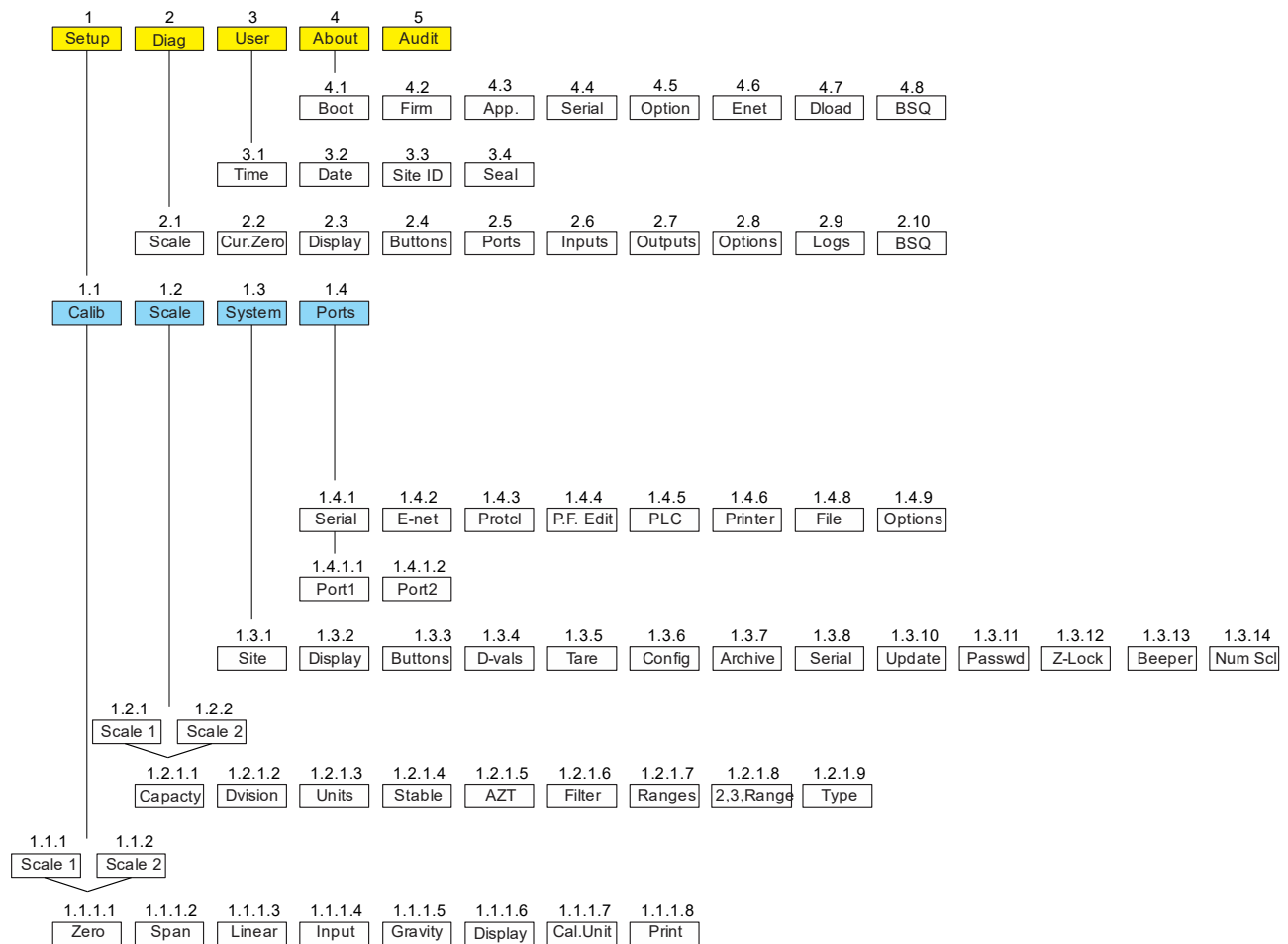

Figure 3.1 Quick Code table

4 User level menus

The USER level (password 111) contains the User, About, and Audit menus arranged as shown in [Figure 4.1](#).

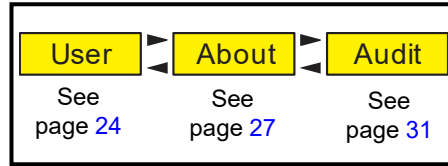

Figure 4.1 USER level (password 111) menus

To access the USER level, from normal weighing mode, press and hold the **F1** key. Enter password 111 and press the **ZERO** key.

4.1 User menu

The User menu is shown in [Figure 4.2](#).

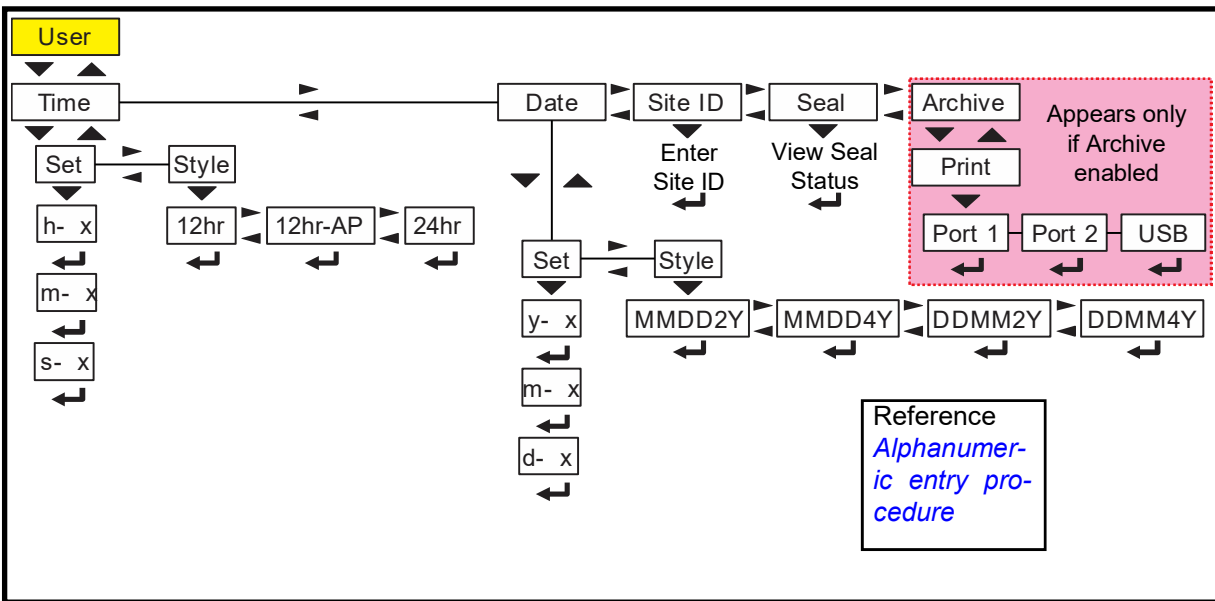
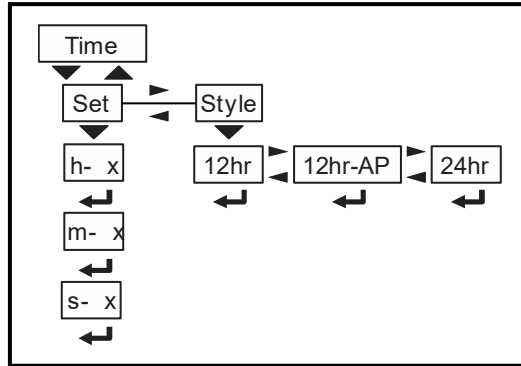

Figure 4.2 User menu

Use this menu to set the time, date, site ID, to see the physical seal status and print archive information. Each is explained below:

4.1.1 Time



Use the **tiME** menu item to set the clock (**SEt**) and to choose the style of the time display (**StYLE**) 12 hr, 12 hr AM/PM or 24 hr.



The Time and Date can be used in print formats.

SEt Use this to enter values for the time.
h- x, = Hour
m- x = Minute
s- x = Seconds

StYLE Choose the style of the time display. Choices are:
12hr, = 12 hour clock
12hr-AP = 12 hour clock with AM/PM
24hr = 24 hour military time

4.1.2 Date

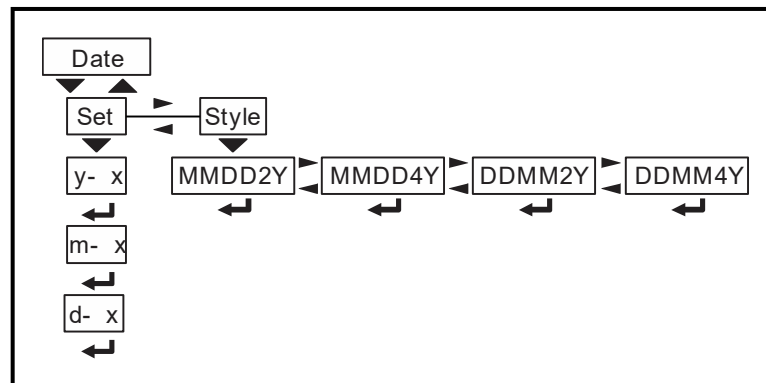

Use the **dAtE** item to set the year, month and day and the style of the displayed date.

SEt Enter values for the date.
y- x = Year
m- x = Month
d- x = Day

StYLE Choose the style of the date display. Choices are:
MMdd2Y = Month, Day, 2-digit Year
MMdd4Y = Month, Day, 4-digit Year
ddMM2Y = Day, Month, 2-digit Year
ddMM4Y = Day, Month, 4-digit Year

4.1.3 Site ID

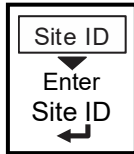

SitE Use this to enter a Site ID.

The Site ID can be used in a print format. Use the alphanumeric entry methods described in 2.3 and 2.4 to enter a Site ID. (maximum 6 digits)

4.1.4 Seal

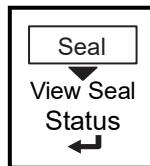

SEAL Use this to view the seal status of the indicator.

This is the status of the physical seal jumper inside the indicator. If the unit is sealed, no changes can be made to the configuration of the indicator. See the note below.



*The seal switch jumper, E7, is located in the top left quadrant of the main PCB. See [ZM jumper and switch settings on page 144](#). If the jumper is installed, the indicator is sealed. This means the only the Diagnostic, User, About, Audit and Supervisor menus can be accessed. Other menus cannot be accessed - the display will flash **SEALEd**.*

4.1.5 Archive

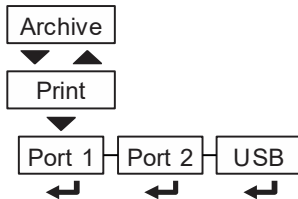

ArchivE Allows you to print the archived transaction information. **This item appears only if so configured in the ADMIN menu.**

To exit the menu, see [Exiting the menus on page 21](#).

4.2 About menu

The About menu is shown in [Figure 4.3](#).

Reference [Alphanumeric entry procedure](#)

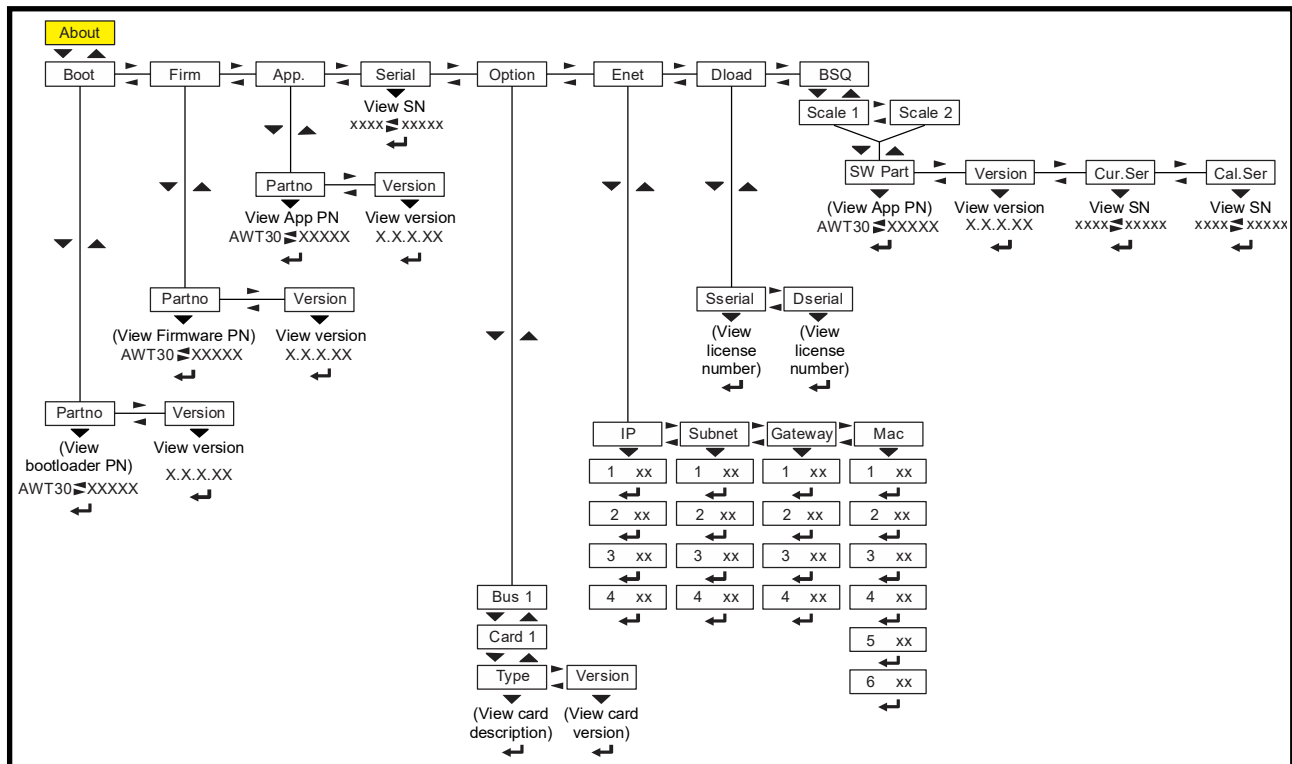

Figure 4.3 About menu

Use this menu to display information about the various items shown in [Figure 4.3](#). Each is explained below:



Definitions:

Bootloader Software that makes the electronics run.

Firmware Embedded system software that creates core functions of the product.

App Specific software that controls the behaviour for a given installation.

4.2.1 Boot (Bootloader)

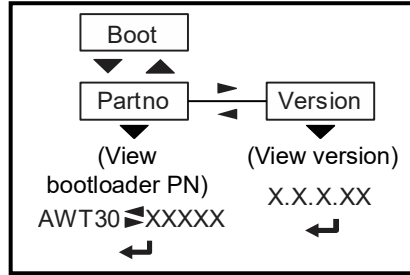

Partno Use this to view the bootloader part number. The part number is displayed in two parts. Press **RIGHT arrow** key or **LEFT arrow** key to toggle the display between the first and second parts of the part number.

VERsion Use this to view the version of the bootloader.

4.2.2 Firmware

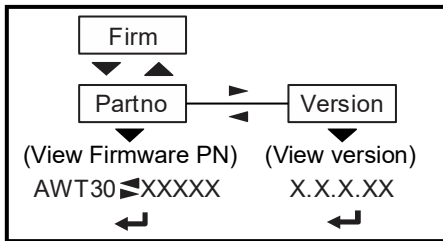

Partno Use this to view the firmware part number. The part number is displayed in two parts. Press **RIGHT arrow** key or **LEFT arrow** key to toggle the display between the first and second parts of the part number.

VERsion Use this to view the version of the firmware.

4.2.3 App

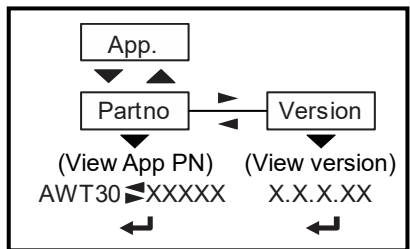

Partno Use this to view the App part number. The part number is displayed in two parts. Press **RIGHT arrow** key or **LEFT arrow** key to toggle the display between the first and second parts of the part number.

VERsion Use this to view the version of the App.

4.2.4 Serial

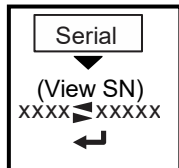

SERIAL Use this to view the Serial Number of the indicator. The number is displayed in two parts. Press **RIGHT arrow** key or **LEFT arrow** key to toggle the display between the first and second parts of the serial number.

4.2.5 Option

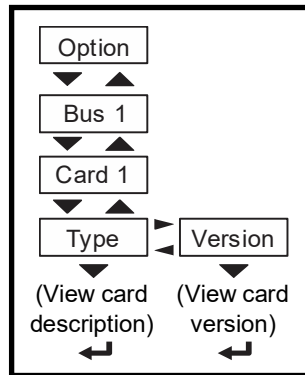

Bus 1 There is only 1 Bus in the ZM400.

Card 1 There is only 1 Card in the ZM400.

oPtion Use this to view the description and version of an installed option card.

4.2.6 Enet

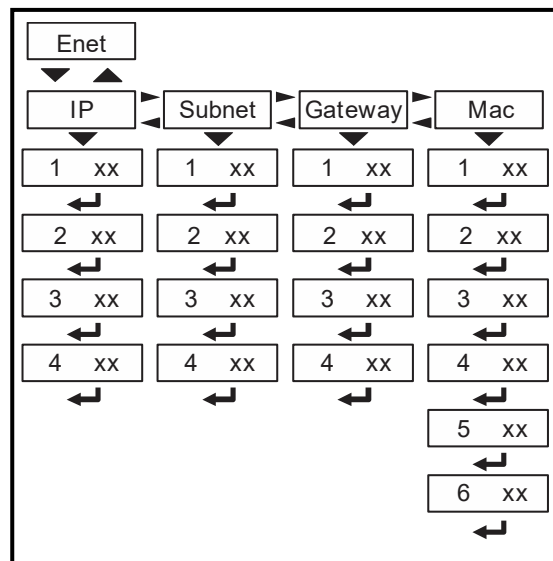

EnEt This stands for Ethernet. Use this to view the network addresses.



If the indicator is connected to an Ethernet network, the values displayed will be the current assigned addresses.

iP Use this to view the IP address.

SubnEt Use this to view the Subnet address.

gAtEWAY Use this to view the Gateway address.

MAc Use this to view the Mac address.



The IP, Subnet and Gateway addresses are a series of four double digit values.

The MAC address is a series of six double digit values: 1 XX, 2 XX, 3 XX, etc.

4.2.7 Download

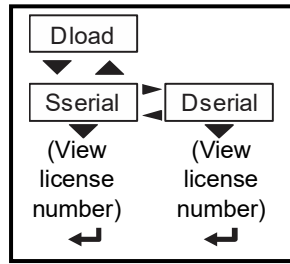

dLoAd

This stands for download. Use this to view these items:

SSEriAL View the license number that created the configuration file.

dSSEriAL View the license number that downloaded the configuration file.

This is used for security and licensing purposes.



To upload a configuration file, the license number of the Configurator (Ztools) software must match one of the license numbers in the indicator Contact AWTX Technical Support for assistance.

4.2.8 BSQ

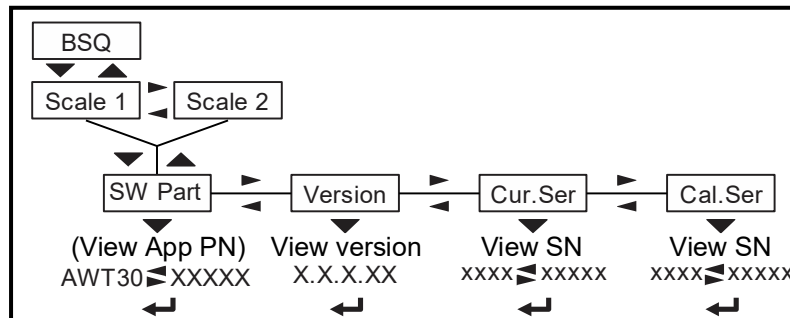

This stands for Bench Scale - Quartzell.

SW Part View the firmware part number of the cell that is connected.

VerSion View the firmware version of the cell that is connected.

cur.SER View the serial number of the cell that is connected.

cAL.SER View the serial number of the cell that **WAS** connected at the time of calibration.

To exit the menu, see [Exiting the menus on page 21](#).

4.3 Audit menu

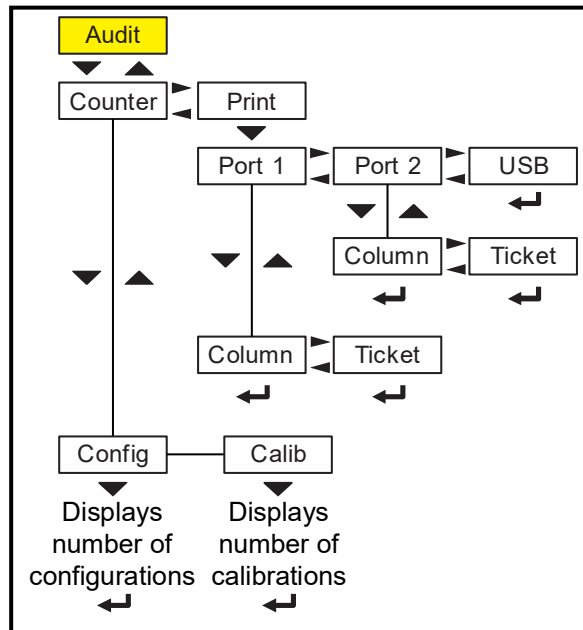
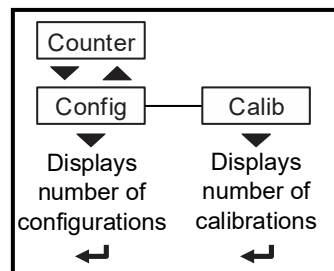

Figure 4.4 Audit menu

Use this menu to display audit counters for configuration and calibration and to print the information. Each is explained below:

4.3.1 Counter



countEr Use this to view these items:

conFig View how many times the indicator has been configured.

cALib View how many times the indicator has been calibrated.

4.3.2 Print

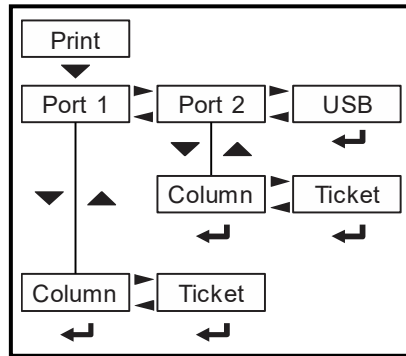

Print Use these to select which port to print the audit report through. Choices are:

Port 1 Under **Port 1** choose to print to a column or ticket printer.

Port 2 Under **Port 2** choose to print to a column or ticket printer.

uSb Printing to USB requires that a USB flash drive is connected to the indicator host USB. Printing to USB will create a folder on the flash drive and a comma separated file with the data.

To exit the menu, see [Exiting the menus on page 21](#).

5 Diagnostics level menus

The DIAGNOSTICS level (password 3570) is the same as the USER level except it adds the Diag menu. The DIAGNOSTICS level is shown in [Figure 5.1](#).

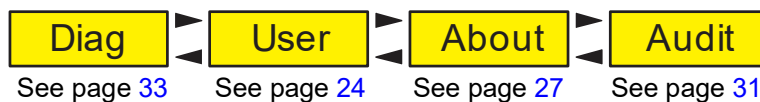

Figure 5.1 DIAGNOSTICS level (password 3570) menus

5.1 Diag menu

Use the Diag menu to check or verify the performance of the indicator. The diagnostic tests available include: Scale A to D to view output from the connected scale base or load device, the current zero offset from calibration zero, a display segment test, a front panel keypad or button test, serial Com ports and USB host port test, remote inputs and outputs test, and an option card test if installed. You can print an error log report that provides information on previous error conditions such as overloads or underloads. The Diag menu is shown in [Figure 5.2](#).

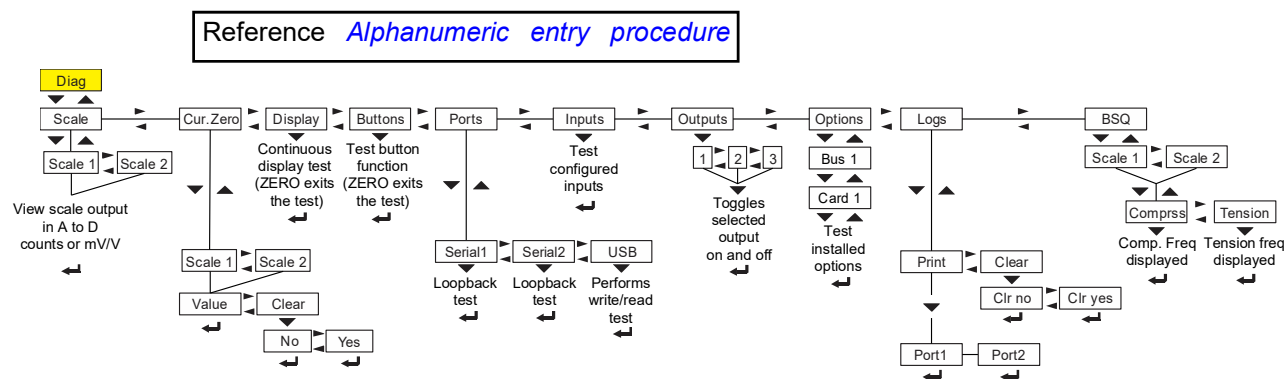

Figure 5.2 Diag menu



The \downarrow and \rightarrow symbols stand for direction moved in the menu. So **Diag** \downarrow **Scale** illustrates that you move down from **Diag** to **Scale**. This will help you keep track of where you are in the menu structure.

Each of the items in the Diag menu is explained below:

5.1.1 Scale

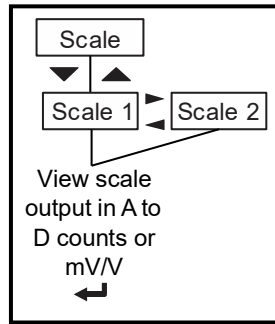

ScALE

Select to view values for Scale 1 or Scale 2, if installed. Use this to view a number representing the A to D counts. The value is only for diagnostic purposes. The value should increase as weight on the scale increases and decrease as weight decreases.

Press **SELECT** to toggle to a mV/V display. This is an approximate value for the mV/V value output by the loadcell. If the scale is a BSQ then you can only view counts, not mV/V.

5.1.2 Current Zero

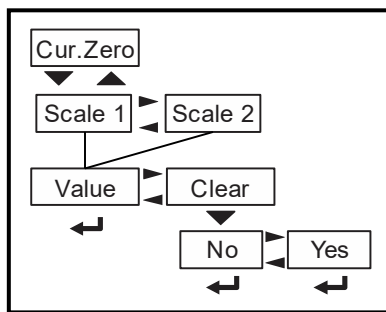

cur.Zero This stands for current zero and represents the weight offset between the calibration zero setting and the current zero setting due to pushbutton zero or Auto-Zero Tracking (AZT) adjustments.

Select to view values for Scale 1 or Scale 2, if installed.

VALuE View the zero offset.

cLEAR Clear the zero offset to return the indicator to calibration zero. Choose Yes or No.



*This can restore the original calibration zero point if the **ZERO** key is accidentally pressed when a tank or vessel contains product that cannot be emptied.*

5.1.3 Display

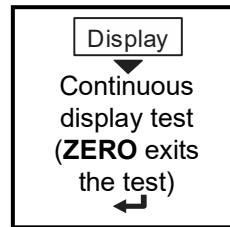

diSPLAY Use to test the segments of the display. Each digit area lights up in progression and continues until you press **ZERO**.

5.1.4 Buttons

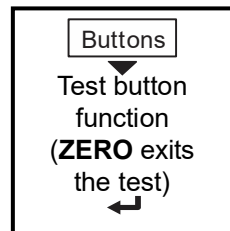

buttonS Use to test the keys. When you begin the test **tESting** is briefly displayed followed by dashes.

Press any key to test if it is functioning and its name or value will be displayed.

Press **ZERO** to stop the test.

5.1.5 Ports

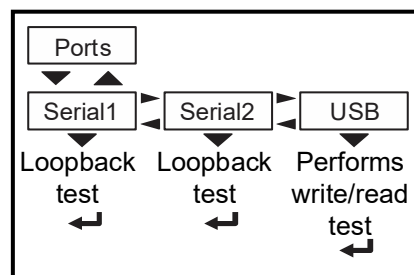

PortS Use this to do a loopback test for serial port 1 or 2 or to perform a write/read test on the USB port.

SEriAL1 or **2** When you pick a serial port to test, **tESting** is briefly displayed and then **PASS** or **FAiL**, depending on if the send and receive lines are jumpered (pass) or not (fail). Add a jumper or wire between the transmit output and receive input. On an external 9 pin connector the transmit line is pin 2 and the receive line is pin 3.



It is recommended that you insert the jumper (a paper clip works) into the external cable connector to validate the wiring and not just the internal ports. See [System block diagram on page 143](#) for I/O configuration of the serial ports TB3.

uSb Use this to test a connected USB flash drive.

oPEn is briefly displayed, then **WritE** is briefly displayed, then **rEAd** is briefly displayed, then **PASS** or **FAiL**, depending on if the USB device is working correctly or not.

If no USB device is plugged in when you begin the test, **oPEn** is briefly displayed, then **no uSb** is briefly displayed, then **uSb**.

5.1.6 Inputs

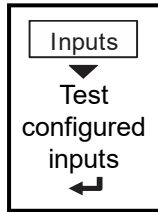

inPutS

The input test is used to verify if external switches wired to the input ports on TB2 are functioning properly.

Follow the steps below to perform the inputs test.

1. Press **SELECT** ...
in 000 is displayed, if no inputs are jumpered.
2. To test input 1, jumper pins 1 and 2 of the I/O connector on the indicator ...
The first digit becomes **1** until the jumper is removed.
3. To test input 2, jumper pins 1 and 3 of the I/O connector on the indicator ...
The second digit becomes **2** until the jumper is removed.
4. To test input 3, jumper pins 1 and 4 of the I/O connector on the indicator
The third digit becomes **3** until the jumper is removed.
5. Press **ZERO** ...
inPutS is displayed.

5.1.7 Outputs

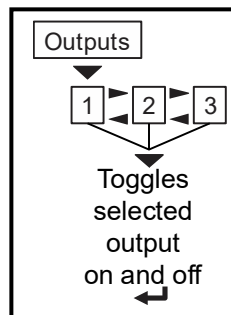

outPutS

The output test is used to verify if external relays or lights (etc.) connected to TB2 are properly wired and functioning properly.

Follow the steps below to perform the output test.



CAUTION: Be sure to take proper precautions to ensure material controlled by the scale outputs will not create a hazardous condition during an output test.

1. Without **PutS** is displayed, press **SELECT** ...
outPut1 is displayed.
2. Press **SELECT** ...
o.1-oFF is displayed.

- Press **PRINT** or **UNITS** to toggle the output **on (o.1-on)** and repeat to turn it **off**.

Output 1 will be toggled on and off as you press the keys. This is shown by the annunciator (*SP1*) on the display turning on and off.

- Press **ZERO** or **F1** to stop the test ...
outPut1 is displayed.
- Press **UNITS** to go to the next output. Repeat the steps to test output 2 and 3.
- When finished, press **TARE** ...
outPutS is displayed.

5.1.8 Options

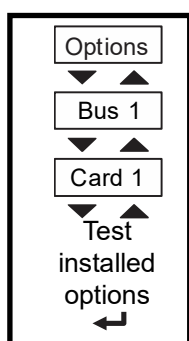

outPutS Use this to test the various installed option cards.

buS 1 Refers to Bus 1, where the option card is attached.

cArd 1 Refers to the option card that is installed.

5.1.9 Logs

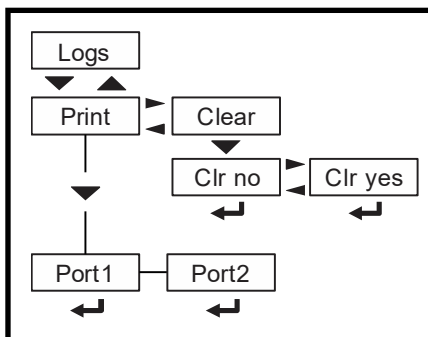

The logs report will print any error conditions that may have occurred such as overloads and underloads

LogS These are logs of various functions. You can print or clear them from memory.

Print Choose to print the log from Port 1 or Port 2.

cLEAR Choose to clear the log from memory.

5.1.10 BSQ

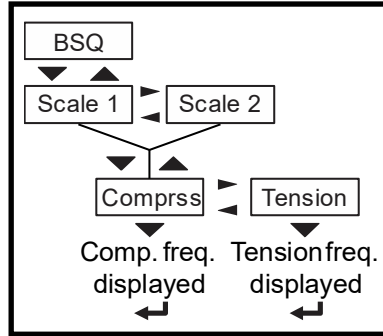

bSQ The BSQ menu item provides the digital frequency information for the crystals on the QDT (Quartzell Digital Transducer).

ScALE 1 or **ScALE 2**:

Select which Scale number the BSQ is assigned, **ScALE 1** or **ScALE 2**

coMPrSS This stands for compression frequency.

tEnSion This stands for tension frequency.

The nominal value for the tension and compression frequency is $47,200 \pm 2000$ kHz. The tension and compression frequencies should each be as stable as the other and within 10% of each other. As weight increases the tension frequency should increase and the compression frequency should decrease.

This completes the Diag menu. To exit the menu, see [Exiting the menus on page 21](#).

6 ADMIN level menus

The ADMIN level (password 3088) is the same as the DIAG level except it adds the Setup menu. The ADMIN level is shown in [Figure 6.1](#).

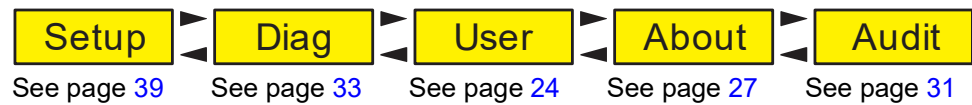

Figure 6.1 ADMIN level

6.1 Setup menu

In the Setup menu there are various submenus available to configure specific sections of the scale operation. The top level items in the Setup menu are shown in [Figure 6.2](#).

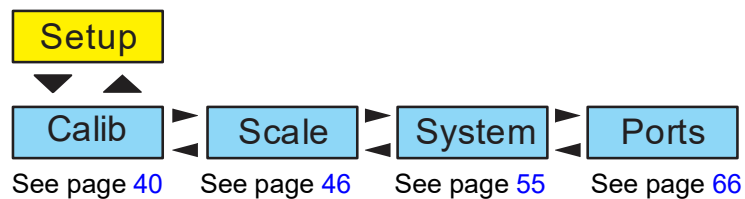

Figure 6.2 Setup menu (password 3088)

Each of the items in the Setup menu are explained in the following sections.

6.2 Calibration Procedure

Use the Calib menu to perform Zero and Span calibration, add Linearity correction points, manually input calibration parameters for Zero and Span, manually input Gravitational correction values, view the live weight, set the calibration unit of measure and print out a calibration report. Follow the menu in [Figure 6.3](#) and the steps that follow.

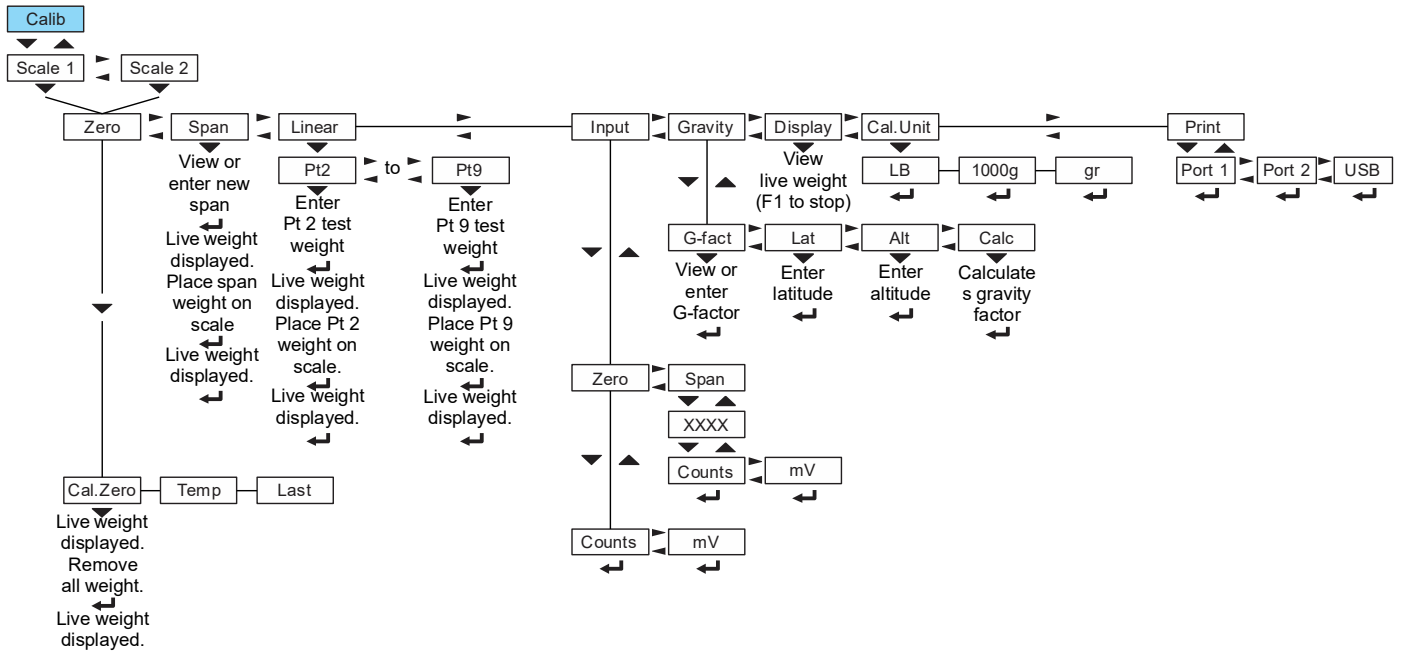

Figure 6.3 Calibrate menu

Access the calibration procedure directly using the calibration password, 2580, or access it through the Setup menu, password 3088. See [Alphanumeric entry procedure \(ZM401 only\)](#) on page 17.

6.2.1 Scale 1-2

Select the scale to be calibrated, Scale 1 or Scale 2. The [Number of Scales](#) on page 65 must be set to 2 to access Scale 2 settings.

6.2.2 Zero Procedure

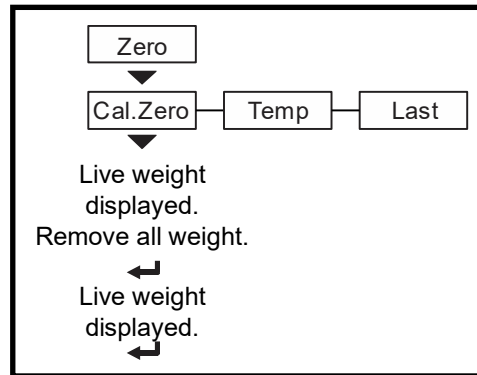

ZERO Access the scale zeroing process.

cAL.Zero Use this to record the zero point. Follow the menu above to complete the zero calibration. A **c** on the display denotes the fact you are in the calibration procedure.



On the initial zero calibration of the indicator to a new scale, the zero cal counts may appear unstable. Continue to the span calibration and when completed the condition should correct itself.

tEmP This is an alternate zeroing procedure. Use this when the product weight on the scale, such as in a tank or vessel, appears to be inaccurate but cannot be removed to establish a no-load condition.

Enter the calibration procedure and select **Temp.** zero. The current weight on the scale will be temporarily assigned as the Cal Zero value. Continue to the SPAN procedure, key in the value of the test weights and place them on the scale and complete the SPAN procedure. The original Cal Zero is restored after exiting the span procedure and the current product weight will now be correctly represented.

Due to factors that created the original inaccuracy, it may be necessary to re-zero the scale when the tank or vessel is empty.

LASt This is an alternate zeroing procedure. Use this if certified test weights placed on the scale display a slightly inaccurate value. Be sure that the scale is at zero before the test weights are added and enter the calibration procedure and select **Last** zero. The last acquired zero value will be assigned as the new Cal Zero value.

Continue to the SPAN procedure without removing the test weights. Key in the value of the test weights on the scale and complete the SPAN procedure. The test weights will now read accurately.

6.2.3 Span Procedure

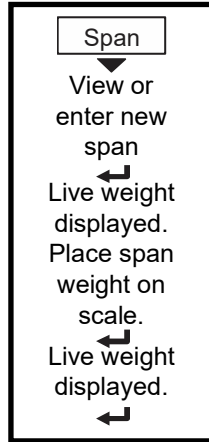

SPAN

To set the Span Calibration point press the **DOWN arrow** key and **XXXX** is displayed with a flashing right digit. This is the current span weight.

Press **ZERO** to accept the displayed span weight or key in your span weight (not to exceed the configured capacity) and press **ZERO**.

c xxx is displayed. This is the current weight on the scale.

Place the span weight on the scale and press **ZERO**. **buSy** is briefly displayed and then **c XXXX** is displayed, which should be the same as the span weight you keyed in. Press **ZERO** and **SPAN** is displayed.

6.2.4 Linearity Procedure



Perform the linearity procedure only if test weights applied to the scale between the zero and span calibration points are showing slight inaccuracies, such as \pm a few divisions. If large inaccuracies are recorded, this indicates a possible mechanical problem or possible loadcell failure which linearity calibration may not be able to correct.

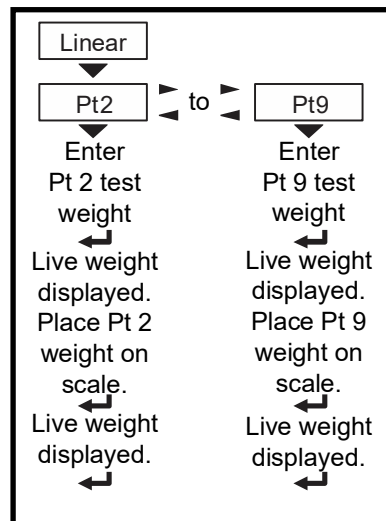

LinEAR

Add up to eight additional calibration points to improve the linearity performance of the scale.

Pt2-Pt9 The points are numbered 2 through 9 because, internally, the zero reference point is point 1 and the span point is point 10.

Follow the same steps as described in the SPAN procedure to enter each linearity point.



Linearity points are cleared if a new span calibration is performed.

6.2.5 Input procedure

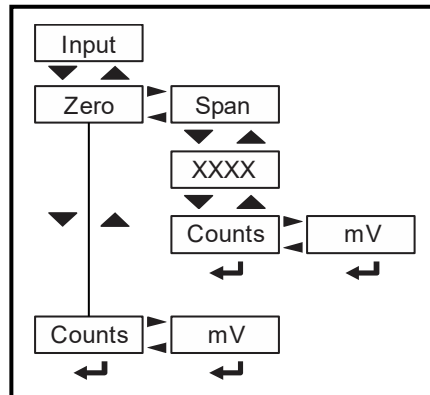

ZERO Use this to enter a value for the zero point.

CountS Use this to enter a zero point using ADC counts.

mV Use this to enter a zero point using a mV/V value.

SPan Accept the flashing displayed span weight (**XXXX**) or key in the span weight that corresponds with the span ADC or mV/V value.

CountS Use this to enter a span using ADC counts.

mV Use this to enter a span using a mV/V value.



The BSQ base only allows entry of Counts for Zero or Span points



The Span value is the differential value of the actual Calibration Zero and Span count (or mV/V) values.

6.2.6 Gravity Factor Procedure

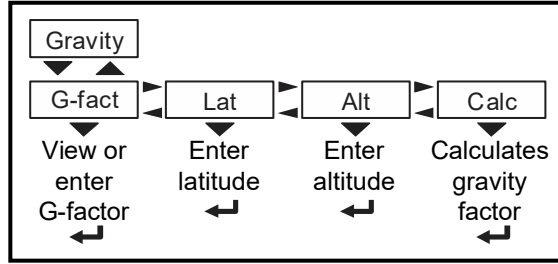

grAvitY Use this item to key in a gravity constant value. If the scale has been calibrated at a different location that has a significantly different gravitational factor than the installation site, and it is not possible to re-calibrate with known test weights, the scale can be adjusted using this gravity factor.

g-FAcT If you know the local gravitation factor (allowable range is 9.70000 to 9.90000), key it in here

OR

If you do not know the local gravitation factor but can determine the approximate latitude and altitude of the installation site, then the indicator can calculate the gravity factor from these two values.

LAt This stands for latitude. Key in the latitude for the installation site. The valid range is 0 to 90. A positive value works for north or south of the equator.

ALt This stands for altitude. Key in the altitude for the installation site. The valid range is 0 to 30,000 ft. (10000 m).

CALC This stands for calculate. The indicator calculates the gravity factor and loads this value as the gravity factor.

Be sure to save the changes when you exit the menu and test the accuracy with a known weight.



CAUTION: Verify with local agencies if adjusting the gravity factor is accepted in your area. It may be required that calibration be done with certified weights.

6.2.7 Display

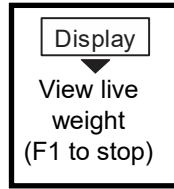

diSPLAY Use this item to view live scale weight while in the calibration menu.



Use the **ZERO** key to zero the indicator so you can add test weights to validate the accuracy of the scale.

6.2.8 Calibration Unit

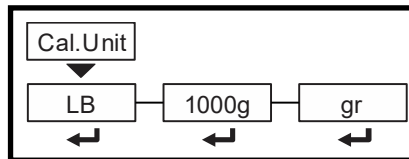

CAL.unit Use this item to set the unit of measure of the weights used during calibration. Choices are **Lb**, **1000g** or **gr**.

6.2.9 Print calibration report

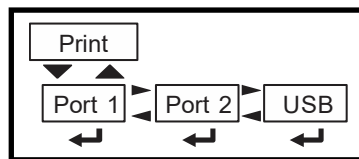

Print Use this print function to print a calibration report through **Port 1**, **Port 2** or to **USB**. This information can be used in the future to restore calibration.

See [Calibration report on page 107](#) to view a representation of the printed report.

This completes the Calib menu. To exit the menu, see [Exiting the menus on page 21](#).

6.3 Scale



CAUTION: Be sure you follow all local weights and measures regulations.

Some parameters may be set automatically by your choice of SitE in the System menu item.

Use the Scale menu to configure the scale operating parameters such as capacity and division size, available units of measure, motion and auto zero tracking values, filtering parameters, range of operation for zeroing the scale, over and underload conditions and the return to gross zero region or band. Refer to the menu in Figure 6.3 and the steps that follow.

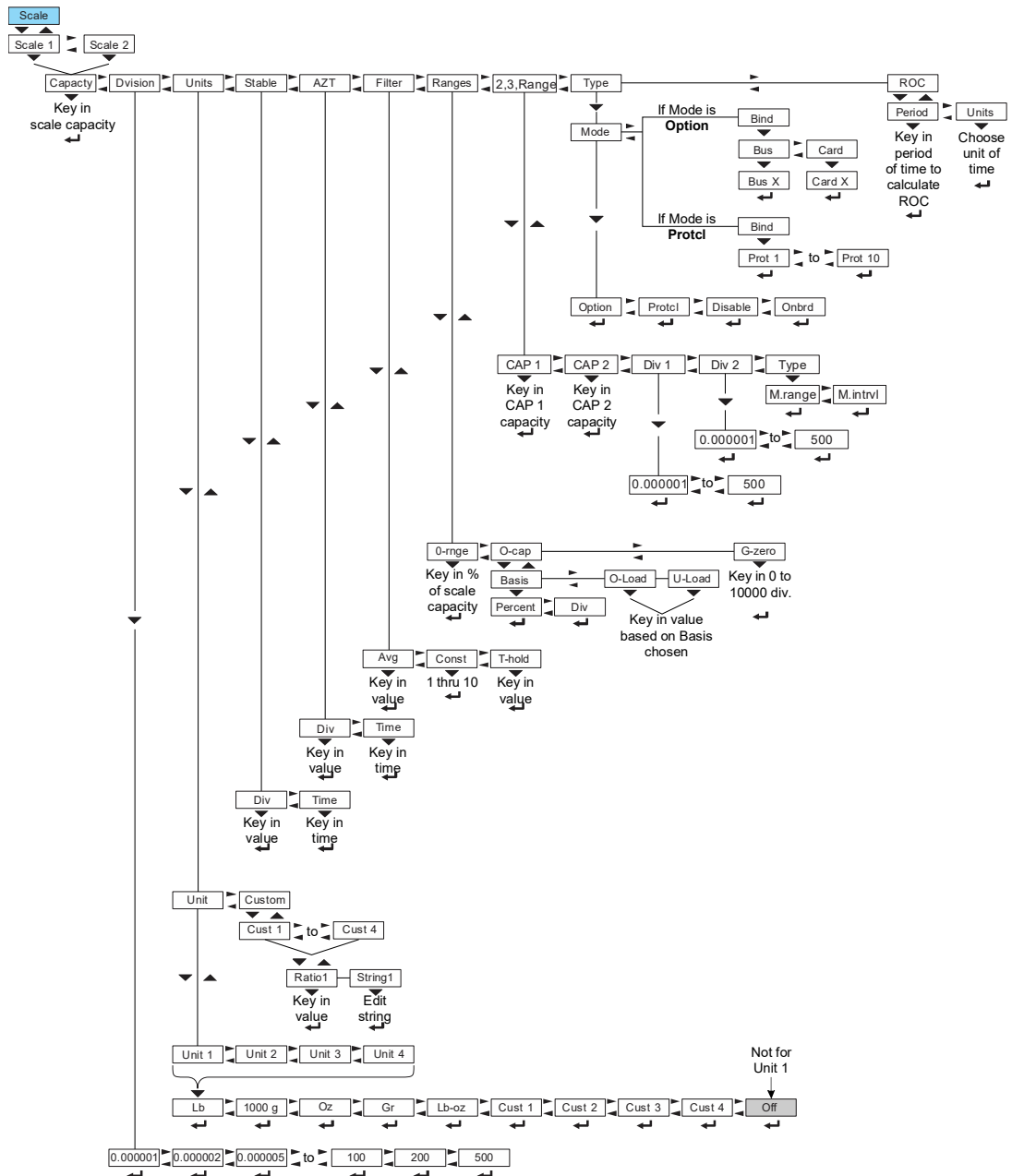
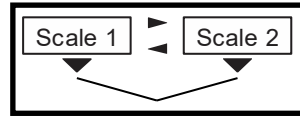

Figure 6.4 Scale menu

Access the Scale menu. See [Alphanumeric entry procedure \(ZM401 only\)](#) on page 17.

6.3.1 Scale 1-2



SCALE 1-2 Select the scale to setup, **SCALE 1** or **SCALE 2**.

The Num Scl menu item in the SYSTEM menu, on page 65 must be set to 2 to access Scale 2 settings

6.3.2 Capacity

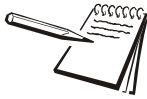

The capacity that you enter should never exceed the rated capacity of the scale that is connected.

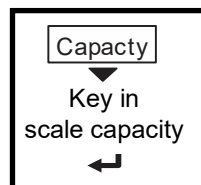

cAPActY Key in a new capacity or accept the displayed capacity.

6.3.3 Division

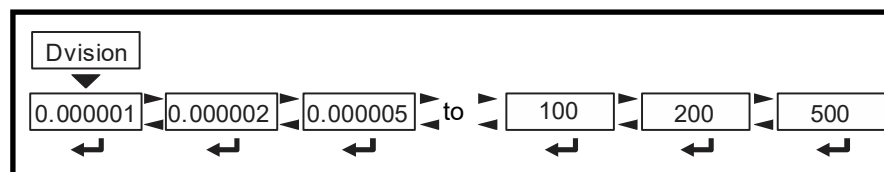

dViSion This stands for division size.

Choices are **0.000001, 0.000002, 0.000005, 0.00001, 0.00002, 0.00005, 0.0001, 0.0002, 0.0005, 0.001, 0.002, 0.005, 0.01, 0.02, 0.05, 0.1, 0.2, 0.5, 1, 2, 5, 10, 20, 50, 100, 200** and **500**. The default value is **1**.



Division sizes for other units of measure are automatically calculated by the indicator.

6.3.4 Units

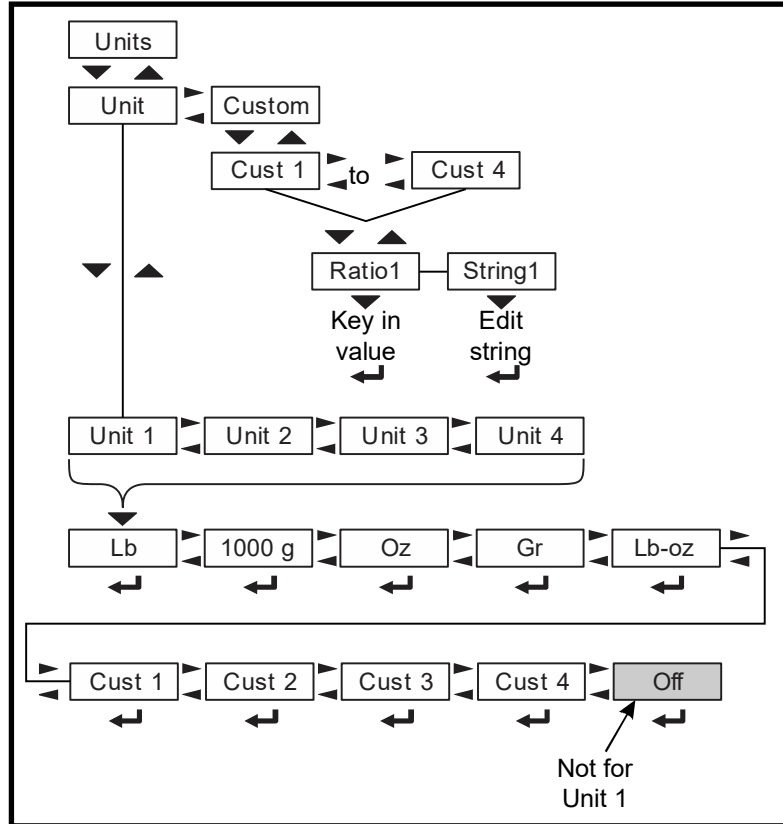

unit From this item you can choose which units of measure are available when the user presses the **UNITS** key during normal weighing. You can have up to four units for viewing. They are listed as: **unit 1**, **unit 2**, **unit 3** and **unit 4**. You can assign any of the following units of measure to any of these: **lb**, **1000g**, **oz**, **gr**, **lb-oz**, **cuSt 1**, **cuSt 2**, **cuSt 3**, **cuSt 4** or **oFF**.

cuStoM This stands for custom unit. To use a custom unit you must first create them by entering a ratio and a string to define it.

cuSt 1-4 You can set up one to four custom units. The process to set up a custom unit is the same for all four.

rAtio The ratio is the number you divide into the calibration unit of measure to create the custom unit. Example: Ratio would equal 2000 if you wanted to convert pounds to tons.

String Use this to enter a string label for the custom unit. Refer to [String index/character data entry on page 18](#) for instructions on how to enter a string label. This is only used when data is transmitted out one of the communication ports.

6.3.5 Stable

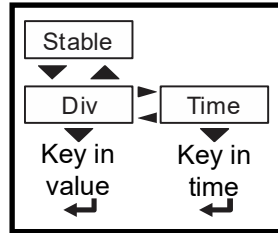

StAbLE Use this parameter to set the stability window for the scale. Set a division window and a time window which will be used to determine when the stability icon will be displayed.

diV Set the division window size to define stability.

timE Set the time window in seconds to define stability. Set both **diV** and **timE** to **0** to disable stability.



The **StAbLE** time value is used during normal operation as the length of time the indicator will continue to check for a 'motion stable' condition after the **ZERO**, **TARE** or **PRINT** button is pressed. If the intended operation cannot be completed before the timeout, **cAnt** is displayed and the key request is ignored.

6.3.6 AZT

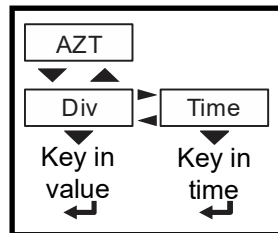

AZt This stands for Automatic Zero Tracking. The **diV** value defines a \pm range around zero. When scale weight is not at the center of zero but inside this range for the time value entered, $\frac{1}{2}$ of the weight will be subtracted. This process is repeated until weight is inside the center of zero region.

diV Set the AZT window size to define stability. 3 divisions is the default value. Set **diV** to **0** to disable AZT.

timE Set the time window in seconds. 1 second is the default value. Set to **0** to disable AZT.

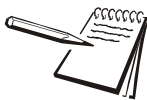

In certain applications, such as when batching product that starts falling slowly onto the scale, it may require disabling AZT or changing the default values to reduce the effect.

6.3.7 Filter

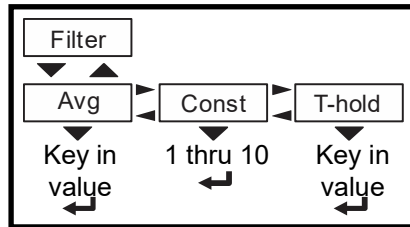

FiLteR Use this to filter out vibrations affecting the scale. Under this item you have the following three parameters to set.

AVg This stands for average. 10 is the default value.

conSt This stands for constant. 1 is the default value.

t-hoLd This stands for threshold. 100 is the default value. When **0** is the threshold value, filtering is always on.

To find the best settings for your filter needs, follow steps 1 to 7.



Default settings are:

AVG = 10

Const = 1

t-hold = 100 (factory default based on 5000 lb capacity)

These values will provide the best weight response for the majority of scale installations. In adverse conditions, where wind, vibration or other conditions are affecting the stability of the weight displayed, refer to the following instructions to improve the performance of the indicator.

If you are using Ztools to configure your scale it will attempt to calculate filtering based upon your capacity and division size used.

- Using the Threshold setting is only recommended if the items to be weighed are similar in weight. If the item weights vary considerably then set the threshold value to 0 and proceed to step 2.

To determine the threshold value first set **t-hoLd** to 0.0, **conSt** to 0, and **AVg** to 1.0. Return to weigh mode and, with a typical item on the scale, observe the weight swings. Record the difference between the highest and lowest displayed weight values. Add 30 to 50% to this value. This is a good starting value for the **t-hoLd** setting. Do not set your indicator to this value until told to in step 7.

- Setting **AVg** to higher values increases the filtering effect.

To do this: Set **t-hoLd** to 0.0, **conSt** to 0, and **AVg** to 10. Check the stability of the scale by exiting to normal weigh mode, remove all weight from the scale and/or press **ZERO** and observe the Center of Zero annunciator. If it is on all the time your scale is stable. If the Center of Zero light blinks, more filtering is required. Go to step 3.

- Repeat step 2 but increase **AVg** by 10.

Keep repeating steps 2 and 3 until the scale is stable or you've tried an Average value up to 80. If the scale is still not stable go to step 4.

- Setting the **conSt** to higher values increases the filtering effect.

To do this: Set **t-hoLd** to 0.0, **conSt** to 1, and **AVg** to 80. Check the stability of the scale by exiting to normal weight mode and observe the Center of Zero annunciator. If it is on all the time your scale is stable. If the Center of Zero light blinks, more filtering is required. Go to step 5.

- Repeat step 4 but increase the **conSt** by 1. Keep repeating steps 4 and 5 until the scale is stable or you've tried the entire range of Constant (10). If the scale is still not stable, decrease your display update rate and start over at step 1 using the new, slower display rate.
- After the **conSt** value is established you may wish to lower the **AVg** value to improve display response time.
- After a final value for **t-hoLd**, **conSt** and **AVg** has been set, enter the **t-hoLd** value established in step 1. If this value is too small your scale will act as if the filtering is off or not working.

Increase the **t-hoLd** value until your scale stabilizes.

If the Threshold value is too high, your scale will react slowly to weight changes.

When filtering is properly adjusted the scale will be stable at zero and will rapidly display a stable test weight value.

6.3.8 Ranges

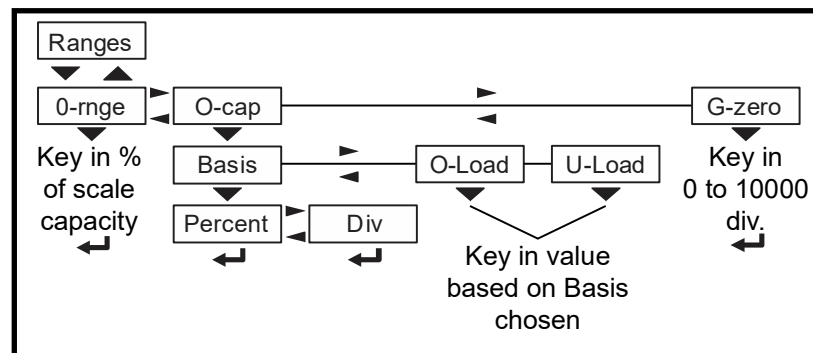

rAngES Use this to set the following ranges.

0-rnge Use this to set the percentage of capacity which can be zeroed off the scale by pressing the **ZERO** key.

o-cAP This stands for over capacity. Use this to configure the over/under capacity function of the scale. See the items below.

bASis Use this to choose what the over and under capacity function is based on.

PERcEnt Use this to choose to base over/under capacity on a percent.

diV Use this to choose to base over/ under capacity on number of divisions.

o-LoAd This stands for overload. Once you've picked the basis for an over capacity condition, use this item to set the value that triggers the overload condition.

u-LoAd This stands for underload. Use this item to set the value that triggers the underload condition.

g-Zero Use this to configure the gross zero band. This is a parameter used to perform the tare clear function and set the Return to Zero range for Autoprint, Accumulate, Checkweighing, Counting and Batch functions. You can enter a value between 0 and 10000 divisions.

6.3.9 2,3,Range

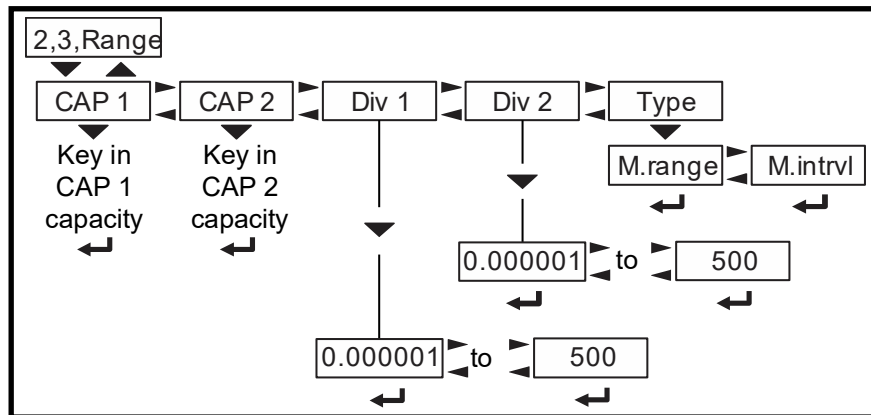

The indicator can be setup for dual or triple ranging operation using multi-range or multi-interval type division size switching

CAP 1 CAP 1 is used for both dual and triple range operation. In dual range operation (and increasing weight) values between 0 and **CAP 1** will use **DiV 1** as the division size and values above **CAP 1** will use the division size entered in [Division on page 47](#).

CAP 2 CAP 2 is used for triple ranging operation only. In triple range operation (and increasing weight) values between 0 and the **CAP 1** will use **DiV 1** as the division size, values between **CAP 1** and **CAP 2** will use **DiV 2** as the division size, and values above **CAP 2** will use the division size entered in [Division on page 47](#).

DiV 1 This is the division size for the 1st weight range.

DiV 2 This is the division size for the 2nd weight range.

tYPE Use this to choose between Multi Range or Multi Interval. The Type setting determines the condition for switching to a new division size when weight is removed.

M.rAngE Multi-range - the division size will change as it enters a new weight range on increasing weight but will not change back to the smaller division size until the display returns to Zero. This is the default setting.

M.intrVL Multi-interval - the division size will change immediately as it enters a new weight range.



Multi-interval is not an agency approved mode of operation.

6.3.10 Type

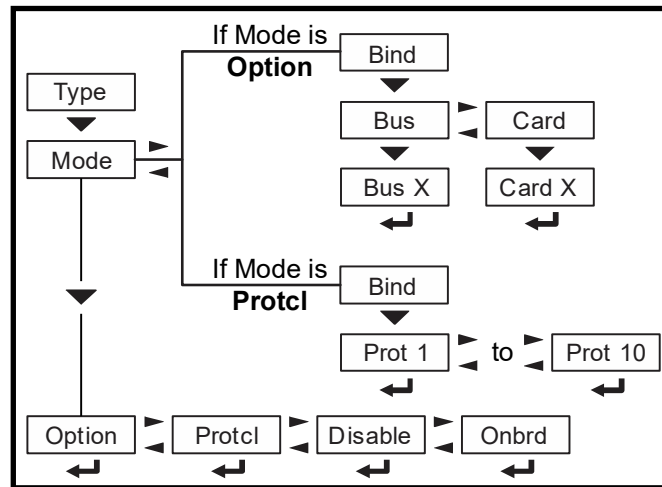

tYPE Use this to select the mode and corresponding binding for the selected scale.

MoDE Select the mode from these choices:

oPtion Pick this mode if you are using the analog scale option card.

ProtCL Pick this mode if you are using the BSQ base connected to a serial port.

diSAbLE Pick this to disable the selected scale. This is the default setting for Scale 2.

onbrd Pick this if you are using the onboard analog scale. This is the default setting for Scale 1.

bind This option appears in two different forms depending on which Mode you pick. If you pick **diSAbLE** or **onboArd** in the Mode menu, the **bind** menu does not appear.

If you choose **oPtion**, this selection requires a bus and card number. For the ZM400 series indicator, only one option card can be installed so these values are already defaulted to bus 1 and card 1 and do not need to be configured.

If you choose **ProtCL**, you must choose a binding with a protocol selection. There are 10 available protocols and the protocol number selected must be matched with a properly configured protocol shown in [Protocol on page 71](#).

6.3.11 ROC

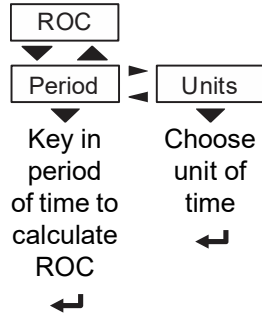

ROC This stands for Rate of Change. Use this to set the parameters to calculate rate of change for flow rates or weight/time applications.

Settings available are:

Period Enter a value for the period of time to calculate ROC.

Units Enter the units for the time: **Seconds, Minutes** or **Hours**.

This completes the Scale menu.

6.4 System

Use the System menu to configure system parameters such as loading defaults for the country of operation, setting available display modes and tare functions, selection of the scale application mode, and several other functions that will be described. Refer to [Figure 6.5](#) as you setup the items of the System menu.

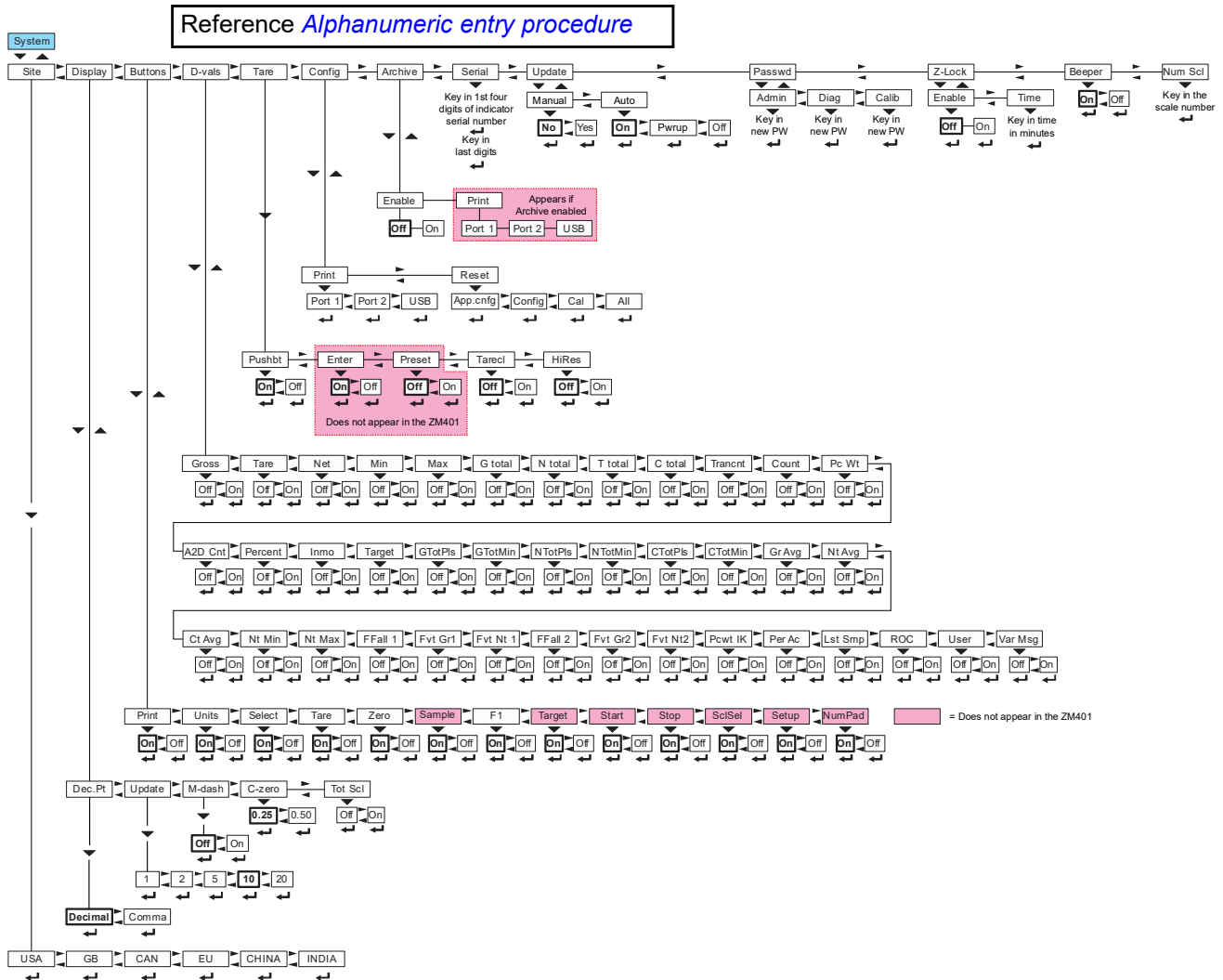

Figure 6.5 System menu



Items in bold boxes and text are default values.

6.4.1 Default Values

Each area of the world has different requirements for indicator configuration. The table below shows all the default values listed for all the different sites covered by the indicator.

	USA	GB	CAN	EU	CHINA	INDIA
Capacity	5000	2500	2500	2500	2500	2500
Division	1	0.5	0.5	0.5	0.5	0.5
Unit of measure	lb	kg	kg	kg	kg	kg
Unit of measure 2	kg	off	off	off	off	off
Cal unit	lb	kg	kg	kg	kg	kg
Cal wt	5000	2500	2500	2500	2500	2500
Zero Range	100	2	2	2	2	2
Over Basis	Percent	Division	Percent	Division	Division	Division
Disp. Update Rate	10	20	10	20	10	10
Separator	decimal	decimal	decimal	comma	decimal	decimal
Date Format	MM-DD-YY	DD-MM-YY	DD-MM-YY	DD-MM-YY	DD-MM-YY	DD-MM-YY
Time Format	12 Hr	24	24	24	24	24
Average	10	10	10	10	10	10
Filter Constant	1	1	1	1	1	1
Filter Threshold	100	50	50	50	50	50
Under Cap. Div.	250	20	250	250	250	250
AZT Time	1	1	1	1	1	1
AZT Div.	3	.25	3	3	3	3
Motion Time	1	1	1	1	1	1
Motion Div.	3	.25	3	3	3	3



Default settings may need to be changed to meet local agency requirements

6.4.2 Site

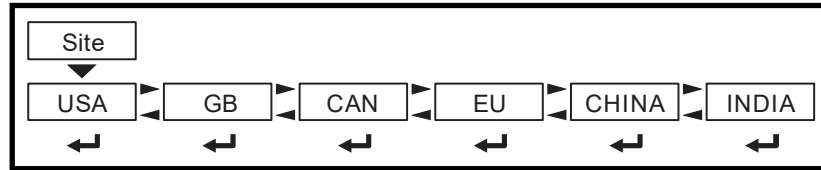

Site Choose your area of operation of the indicator. Choices are: **uSA**, **gb**, **cAn**, **Eu**, **chinA** and **indIA**. This sets the defaults needed for your area when the indicator is reset. See [Default Values](#) on page 56..



CAUTION: Be sure you follow all local weights and measures regulations.



To reset the default settings affected by the Site selection, choose an alternate Site selection and press **ZERO**, then re-select the original Site selection.

6.4.3 Display

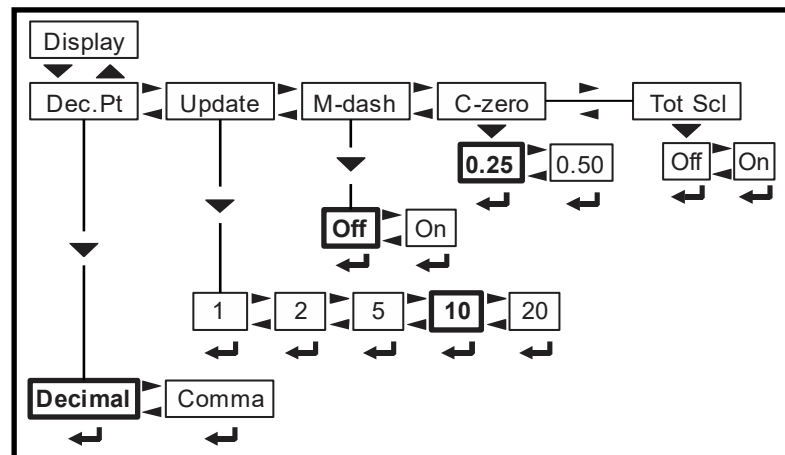

diSPLAy Use this to set the following parameters for the display.

dEc.Pt This configures whether a decimal point or comma is used to separate whole and fractional numbers.

uPdAte This configures the number of display refreshes per second. Choices are **1**, **2**, **5**, **10** and **20**.



Lowering the update rate can sometimes improve stability of the display in noisy environments, e.g. vibration or wind.

m-dASH If enabled, the display will show dashes during motion.

c-Zero Choose the center-of-zero window size to be **0.25** or **0.50** division. If the weight is within this window, the zero annunciator on the display will be lit.

tot-Scl Use this to enable display of the total of both scale weights if two scales are installed and enabled. If enabled ON on a ZM405 use the **SCALE** key to toggle between Scale 1, 2 or total of both. The ZM401 requires the application to determine the method of selecting the active scale or total.

6.4.4 Buttons

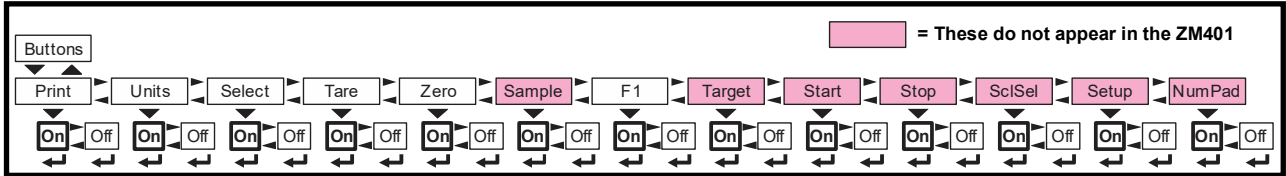

buttonS Use this item to configure each button (key) **on** or **off**. This allows you to limit the front panel function to suit your situation. Follow the same procedure for each key to turn it on or off. **on** is the default value for all the buttons.

The complete list of buttons for the ZM405 is shown in the menu above. The keys in the shaded boxes do not appear in the ZM401 menu.

6.4.5 Display values

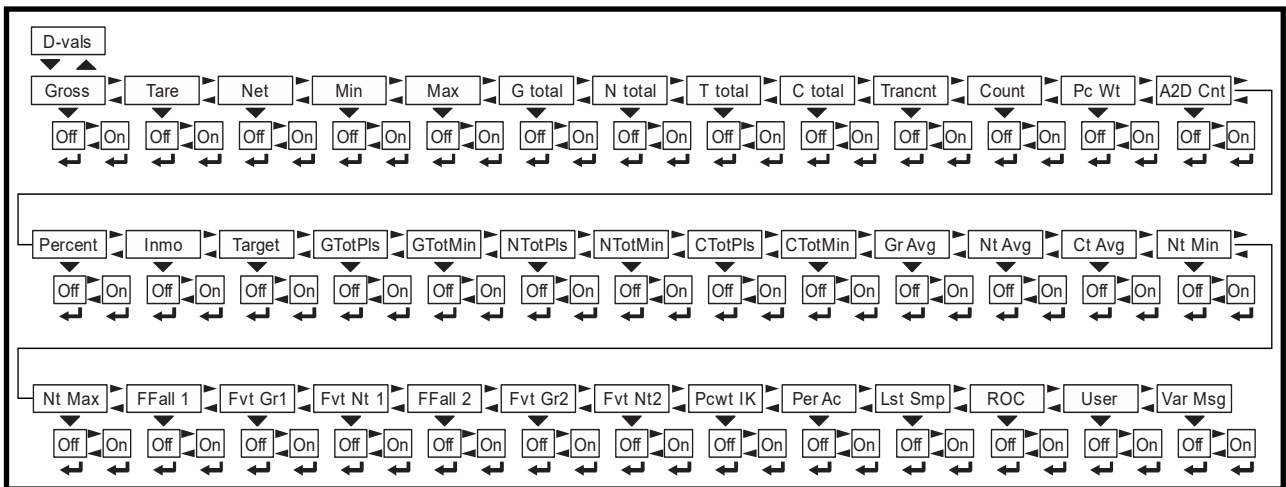

d-VALS This stands for the displayable active values. In normal weighing mode, press **SELECT** to scroll through all enabled values. Activate the ones in the following list that you want the ability to view during normal weighing mode.

groSS Activate this to see the gross weight value.

tArE Activate this to see the tare weight value.

nEt Activate this to see the net weight value.

Min	Activate this to see the minimum weight value.
MAX	Activate this to see the maximum weight value.
g totAL	Activate this to see the gross total weight value.
n totAL	Activate this to see the net total weight value.
t totAL	Activate this to see the tare total weight value.
c totAL	Activate this to see the count total value.
trAncnt	Activate this to see the transaction count value.
count	Activate this to see the count value.
Pc Wt	Activate this to see the piece weight value.
A2d cnt	Activate this to see the A to D count value.
PErcEnt	Activate this to see the percent value.
inMo	Activate this to see the averaged weight value when an inmotion application is operating.
tArgEt	Activate this to see the target weight value.
gtotPLS	Activate this to see the gross total + current gross value. This parameter is commonly used in conjunction with the accumulation procedure for multiple-dump batching applications.
gtotMin	Activate this to see the gross total - current gross value.
ntotPLS	Activate this to see the net total + current net value.
ntotMin	Activate this to see the net total - current net value.
ctotPLS	Activate this to see the count total + current count value. This parameter is commonly used in conjunction with the accumulation procedure for multiple-dump batching applications based on piece count.
ctotMin	Activate this to see the count total - current count value.
gr AVg	Activate this to see the average gross value. This is the average gross weight calculated through use of the % + Averaging macro command. This command can be used to start, stop and resume averaging. A separate average gross parameter is maintained for each enabled scale.
nt AVg	Activate this to see the average net value. The characteristics of the average net parameter are identical to that of the average gross.
ct AVg	Activate this to see the average count value. This represents the number of times the gross and net weight were accumulated when using the %+ Averaging command.
nt Min	Activate this to see the net minimum value.
nt MAX	Activate this to see the net maximum value.

- FFALL 1** Activate this to see the free fall 1 value. Free fall is like preact. This is the calculated amount of material that will fall on the scale base on the current flow rate.
- Fut gr 1** Activate this to see the future gross value (#1). This represents a predicted gross weight calculated by multiplying the current rate by the free fall time and adding the result to the current gross weight:
 Future Gross = Rate X Free Fall + Gross
- Fut nt 1** Activate this to see the future net value (#1). This represents a predicted net weight calculated by multiplying the current rate by the free fall time and adding the result to the current net weight:
 Future Net = Rate X Free Fall + Net
- FFALL 2** Activate this to see the free fall 2 value. Free fall is like preact. This is the calculated amount of material that will fall on the scale base on the current flow rate.
- Fut gr 2** Activate this to see the future gross value (#2). This represents a predicted gross weight calculated by multiplying the current rate by the free fall time and adding the result to the current gross weight:
 Future Gross = Rate X Free Fall + Gross
- Fut nt 2** Activate this to see the future net value (#2). This represents a predicted net weight calculated by multiplying the current rate by the free fall time and adding the result to the current net weight:
 Future Net = Rate X Free Fall + Net
- PcWt 1X** Activate this to see the average piece weight x 1000. The average piece weight x 1000 parameter represents the average weight of 1000 pieces as calculated during the sampling routine.
- PEr Acc** Activate this to see the percent accuracy value. The percent accuracy parameter represents the minimum accuracy achieved during the last sample routine. Only one percent accuracy parameter is maintained for all enabled scales.
- LSt SMP** Activate this to see the Last sample size value. The last sample size parameter represents the number of pieces used during the last sample routine to determine the current average piece weight. Only one last sample size parameter is maintained for all enabled scales.
- roc** Activate this to see the rate of change (ROC).
- uSEr** Activate this to see ?
- VArMSg** Activate this to see ?

6.4.6 Tare

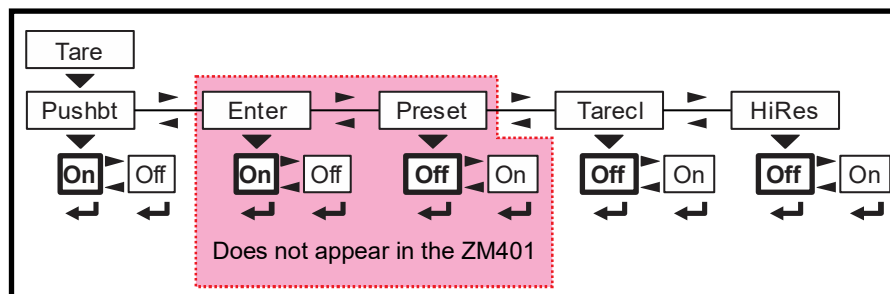

Pushbutton and keyboard entry tare can both be set to on simultaneously. The **TARE** key must be enabled in the **Button** menu.

tArE Use this item to set the type of tare entry and the tare autoclear functions.

PuShbt This stands for pushbutton tare. Enable this to use the **TARE** key to tare weight from the scale. **on** is the default value.

EntEr This stands for keypad entry tare. Enable this and you can key in a tare value and press **TARE** to activate it during normal weighing mode. **oFF** is the default. This item does not appear in the ZM401 model.

PrESEt This stands for preset tare. Preset tare values are entered in a password protected menu and can be recalled, if this parameter is enabled. **oFF** is the default value. This item does not appear in the ZM401 model.

tArEcl This stands for automatic tare clear. Enable this to automatically clear a tare after a weighing when the weight falls into the gross zero band. **oFF** is the default value.

hirES This stands for high resolution tare. If **on**, the indicator does not round the tare value to the current division size. Choose **on** to enable high resolution tare or **oFF** to disable high resolution tare. **oFF** is the default value.



If preset tare is enabled, pushbutton tare and keyboard entry tare will be disabled automatically.

Preset Tares are entered in the Supervisor menu (ZM405 only). See the User manual.

6.4.7 Config

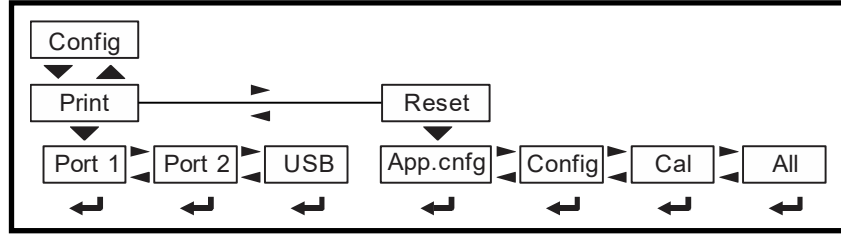

conFig Use this to print out the configuration data through one of the ports or reset the configuration, calibration or database to factory defaults. Follow these steps:

Print Use this to print the indicator configuration information. You pick the port to use for printing in the following steps. See the extensive list in Chapter 9 - *Printed reports (page 107)*

Choices are **Port 1**, **Port 2** and **uSb** (text file).



If USB is selected, a USB flash drive must be installed to create the text file of the indicator configuration.

rESEt Under this item you can choose to reset the **APP.cnFg** (reset configuration settings back to how the application had it set when it was last downloaded), **conFig** (factory default settings) and **cAL** (factory default calibration) memory or choose **ALL** to reset both config and cal factory defaults at once.

6.4.8 Archive

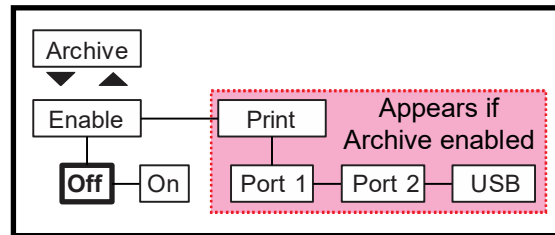

ArchIvE This stands for electronic archive. In other regions it is known as an alibi memory or tally roll. These will be transmitted via configured communications ports. These reports can be used to confirm a weighment if it is ever in dispute. Only records that are qualified as a LEGAL record, per site motion criteria, are considered as entries to this log.



The indicator has memory capacity to store approximately 5,000 transactions.

The Archive report uses a rolling memory configuration (FIFO) so the oldest transaction will be written over first when all the memory slots are filled.

EnAbLE Choose **on** to enable a PC query. If enabled, a **Print** menu item appears to the right of **EnAbLE**.

Print You can choose to print the archive from Port 1, 2 or to USB. (USB device must be installed)

6.4.9 Serial

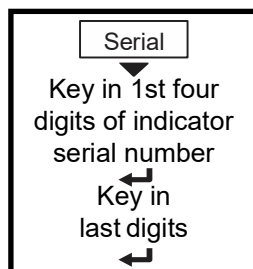

SEriAL Use this to record the serial number of the indicator. The serial number is located on the label attached to the indicator.

6.4.10 Update

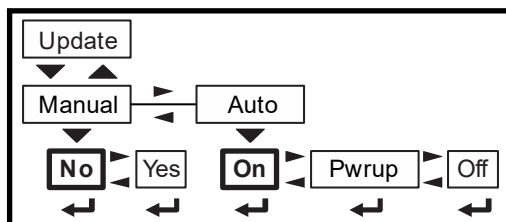

uPdAtE Use this to set the conditions for the indicator to accept software updates from a remote site. If connected to the internet, the indicator can accept a software update file via FTP. The software update can be installed manually or automatically when the file is received or on the next powerup.

MAnuAL Choices under this are **no** and **YES**. Choose **YES** to start the update process. Choose **no** to not do an update. **no** is the default.



Manual update selection only applies when AUTO update is disabled and only if a file has been sent via FTP to the indicator and is waiting to update.

If you choose **no**, no update occurs and **MAnuAL** is displayed. If you choose **YES**, the indicator will update and reboot.

Auto Choices under this are **on**, **PwruP** and **oFF**. Choose **on** (the default setting) and the indicator will update anytime it receives an update via FTP. Choose **PwruP** to have the indicator auto-update on powerup if an update is available. Choose **oFF** to turn auto-update off.



If **Auto = oFF**, the only way to update the indicator is to use the **MANuAL** update and select **YES**.

6.4.11 Password

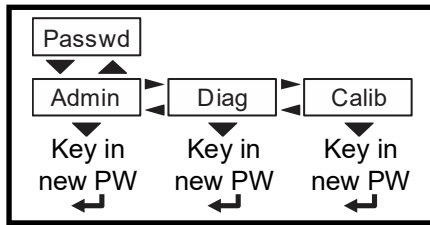

PASSWd Use this to change the password for the **AdMin**, **diAg** and **cALib** menus.



If the **ADMIN** password is changed, be sure to keep a record of it available for service personnel or they may not be able to perform required maintenance when necessary.

6.4.12 Z-Lock

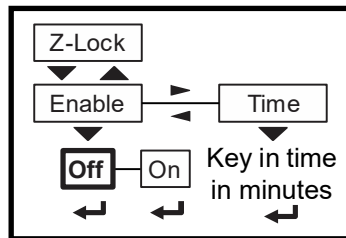

Z-Lock This stands for zero lock. Use this to enable and configure the zero lock feature during an automated weighing process. When enabled, if the scale does not achieve a stable, gross zero condition some time within X minutes (the time you configure), then the indicator locks up and displays a message in three, one second displays: **Z-Lock PrESS ZERo**. The operator must press **ZERO** to unlock the indicator.

EnAbLE **oFF** or **on**. **oFF** is the default.

timE Use this to set the time value, in minutes, for this function. 60 minutes is the default

6.4.13 Beeper

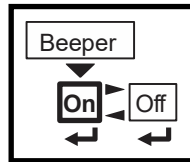

bEEPER Use this to enable or disable the beeper sound when you press keys. **on** is the default.

6.4.14 Number of Scales

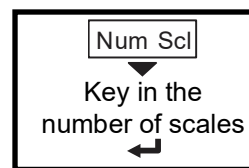

num Scl Use this to key in the number of scales attached to the scale. To access settings for Scale 2 and to use the **SCALE** key this must be to 2. Default is 1.

This completes the System menu.

6.5 Ports

Use the Ports menu to configure the scale communication ports and protocols for connection to external devices. Detailed descriptions are provided in each section below. Refer to [Figure 6.6](#).

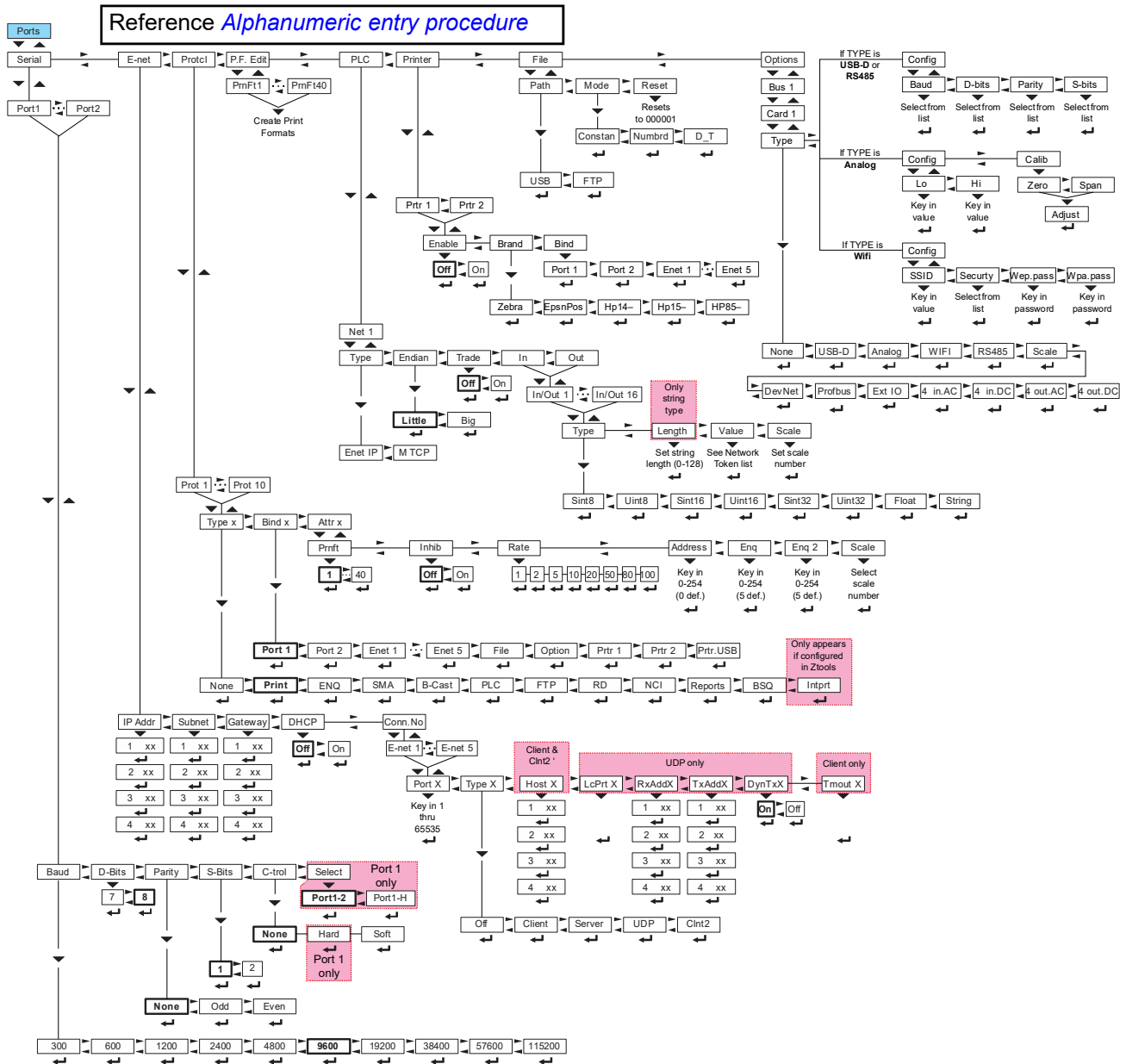
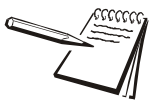
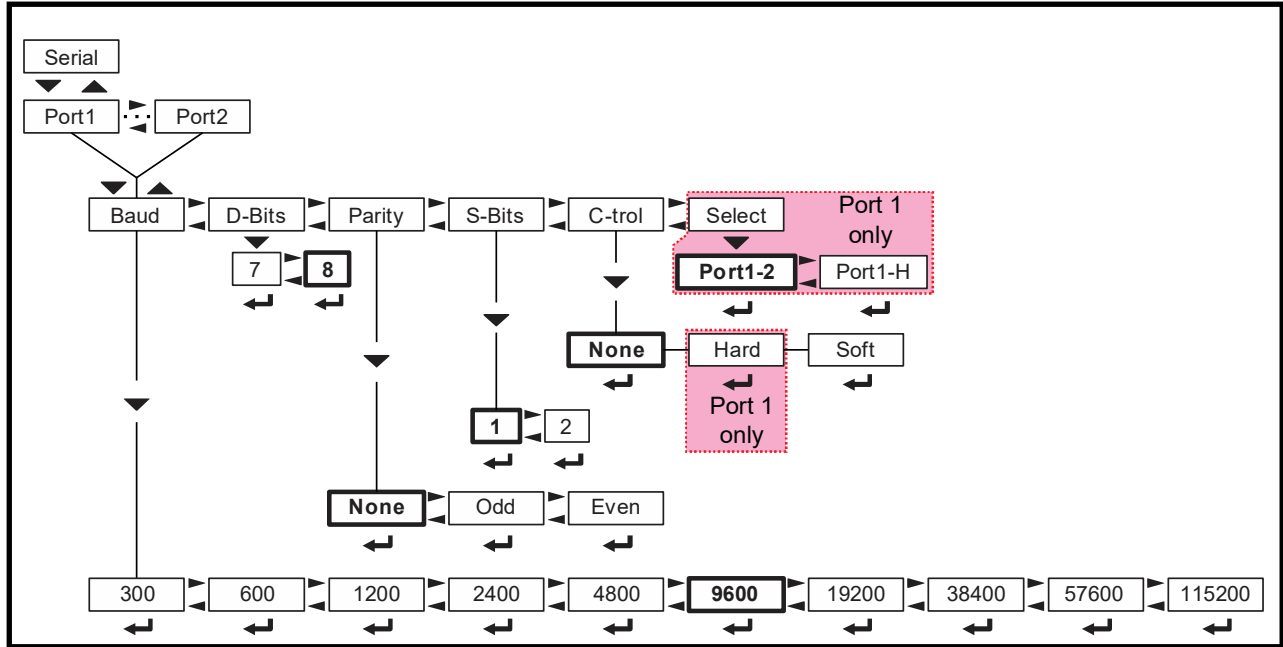

Figure 6.6 Ports menu



Items in bold boxes and text are default values

6.5.1 Serial



SERIAL Use this to set the serial communication parameters. Choose Port 1 or Port 2 to begin.

bAud Set the baud rate from the available choices. **9600** is the default value.

d-bitS Choose **7** or **8** data bits. **8** is the default.

PARitY Choose **noneE**, **odd** or **EVEn**. **noneE** is the default.

S-bitS Choose **1** or **2** stop bits. **1** is the default.

c-troL Use this to set the flow control for the port. Choices for Port 1 are **noneE**, **hArD** or **SoFt**. Choices for Port 2 are **noneE** or **SoFt**. Default is **noneE** for both ports.

hArD Stands for hardware flow control. If wired, a device can stop the indicator and restart it for transmitting. Example is the CTS signal on a PC serial port or print busy output on a Line or Lister printer.

SoFt Stands for software handshaking. This allows a device to start and stop the indicator transmit by sending Xon or Xoff characters.

Port 1 has both **hArD** and **SoFt**. Port 2 does not have hardware handshaking.

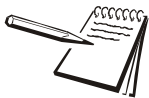

Hardware flow control on Port 1 is only available if Port1-H is selected and Jumper P5 is in position 1.

See the photo in section [ZM jumper and switch settings](#) on page 144.

SELEct Use this to select Port 1 and Port 2 (**Port1-2**) or just Port 1 with full hardware flow control capability (**Port1-h**).

6.5.2 Ethernet

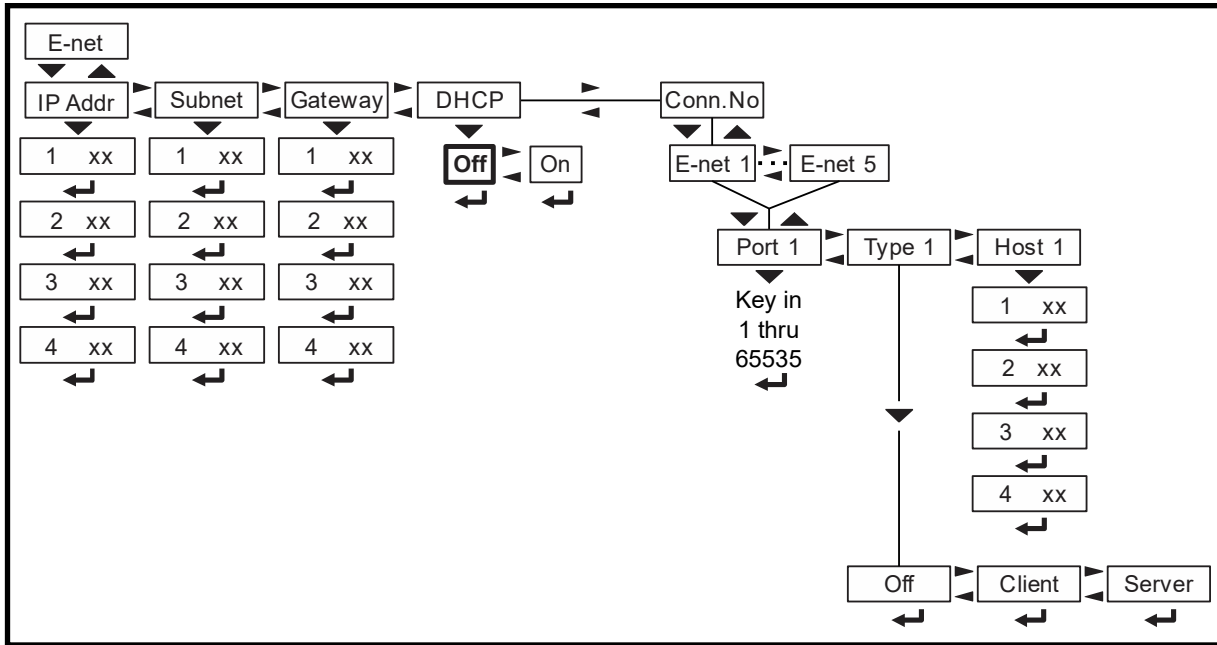

E-nEt Use these menu items to setup the Ethernet port.

iP Addr Use this to key in the static IP address of the indicator.

The IP address is the unique address for a device which is part of an Ethernet network. IPv4 is supported by this indicator. The address is a numeric entry in four parts or octets (###. ###. ###. ###).



The DHCP setting is **OFF** by default so the indicator will use the entered IP address for connecting directly to a PC or other static IP address devices.

If DHCP setting is **on** the Ethernet settings must be assigned by the network DHCP server

Key in each octet and press **ZERO** to accept it.



Typically devices within a network share the same address for the first three octets (network address) and each device will have a unique setting or value for the fourth octet (device address).

SubnEt The Subnet Mask address is used to divide a network into smaller subnets. The address is a numeric entry in four parts or octets (###. ###. ###. ###).



Typically the subnet mask address is set to 255,255,255,0 which means the first three octets in the device network are the same and only the fourth octet of the IP address is unique for each device.

Key in each octet and press **ZERO** to accept it.

gAtEWAY The Gateway address allows one network a gateway to another network. The address is a numeric entry in four parts or octets (###. ###. ###. ###).



In most simple networks a gateway address is not used and is set to 0,0,0,0. If the indicator is part of a network that uses an access point to another network, then a gateway address may be required. (Consult the site IT specialist)

Key in each octet and press **ZERO** to accept it.

dhcP Use this to enable or disable DHCP capability. This allows a DHCP server to automatically set the indicator IP, subnet and gateway addresses. Choices are **on** (enabled) or **oFF** (disabled). Default is **oFF**.



*If DHCP is enabled **on**, the above settings for the IP, Subnet and Gateway are set by the network server. In applications where the indicator Ethernet port is connected directly to a PC, laptop, printer or other non-DHCP device, you must set DHCP to **oFF**.*

con.no This stands for connection number. Under this are **E-Net 1** through **E-Net 5**. These are the numbered Ethernet ports.

E-Net 1-5 Choose the Ethernet port to set up. Choices available under

Type x Use this to set the type of connection; **Off**, **Client**, **Server**, **UDP** or **Clnt2**.



*If the Ethernet port connection is to a PLC, the **Type** setting must be set to **Off**.*

*If **Type** is set to **Off**, it disables the selected port from communication to a server or client on the network.*

*The **Client** selection is typically used when the indicator(s) is connected to a print server or a shared printer on the network.*

*Host IP Address is only used if the **Type** setting is **Client** for this port connection.*

If **Type** is set to **Off**

Type x is the only item listed under **E-Net x**. You must choose one of the other choices to see other items listed.

If **Type** is set to **Client**

Type x, **Port x**, **Host x**, and **Tmout x** are displayed. These are explained below.

Port x This stands for Remote Port. You need to pick the remote port number to send messages to and receive messages from. Key a port number from 1 to 65535.

Host x This is the host IP address of the server. Key in a value from 0 to 255.

Tmout x If no messages are received within the timeout period the socket will try to reconnect. Key in a value in seconds from 0 to 60000. Default is 0.

If **Type** is set to **Server**

Type x and **Port x** are displayed. Allowable values for each are listed below.

Port x This stands for Remote Port. You need to pick the remote port number to send messages to and receive messages from. Key in a port number from 1 to 65535.

If **Type** is set to **UDP**

UDP stands for User Datagram Protocol. **Type x**, **Port x**, **LcPrt x**, **RxAdd x**, **TxAdd x** and **DynTX x** are displayed. These are explained below.

Port x This stands for Remote Port. You need to pick the remote port number to send messages to and receive messages from. Key a port number from 1 to 65535.

LcPrt x This stands for Local Port. This is the local port that the remote IP will send messages to. Key in a port number from 1 to 65535.

RxAdd x This stands for Receive from Address. This is the IP address to receive messages from. A specific IP address could be specified, or an address of 0.0.0.0 could be used to receive from any remote IP address. Key in a value from 0 to 255.

TxAdd x This stands for Send to Address. This is the default remote IP address to send messages to. This address may not be used at all if dynamic address is set to ON. Key in a value from 0 to 255.

DynTX x This stands for Dynamic Address. Choices are **Off** or **On**. If **On** the firmware will change the send to IP address to the address that a message was last received from, so that a response is sent to the sender that last sent a message to the indicator. If set to **Off** then all messages will be sent to the IP address specified by the **TxAdd x** setting. Default is **Off**.

If **Type** is set to **Clnt2 x** This stands for Client 2. The socket opens and closes every time before and after sending data. **Type x** , **Port x** , **Host x** , and **Tmout x** are displayed. These are explained above.



Some port numbers are reserved. Contact your IT department for the correct port number to use.

6.5.3 Protocol

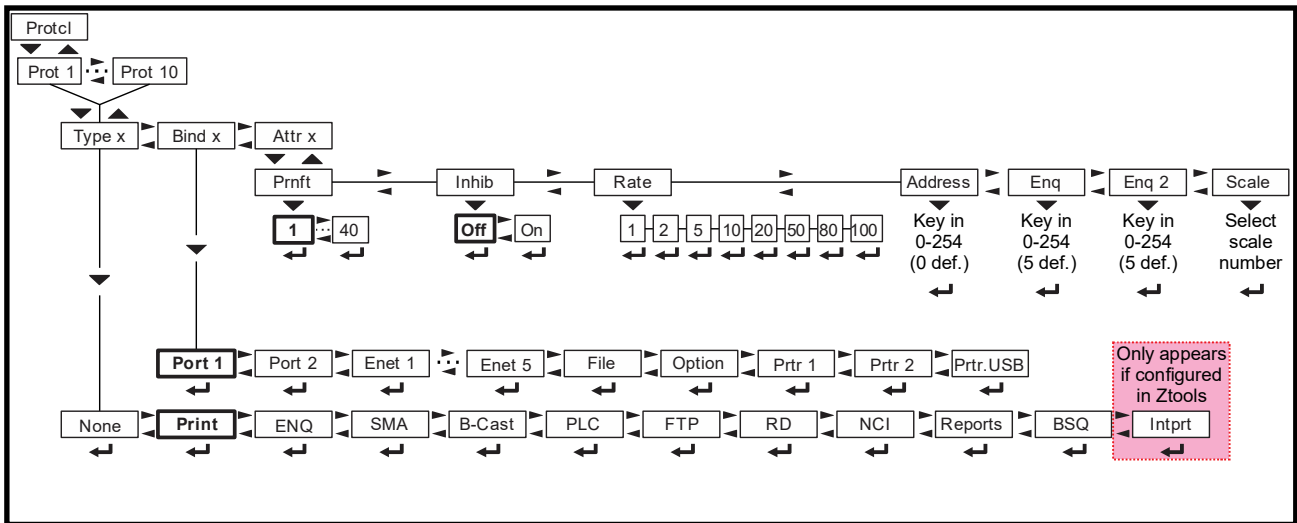

Protcl Use this to configure up to 10 communication protocols. These protocols define the information sent to and from specific types of communication equipment.

For each protocol you set the type, the binding and the attributes, described below.



Which Attributes and Bindings apply to the selected Type will be described in the detailed descriptions below.

Type x - Choose the method to send and receive data for Protocol x, where x = 1 to 10.

nonE Choose this to disable the selected protocol.

Print Choose this when you want to press the **PRINT** key or when using Autoprint to send the data through the selected binding (Port) using the associated attributes.

- Enq,** Choose this to send data when the indicator receives the configured enquire code from an external device. The information will be sent through the selected binding using the associated attributes. See [ENQ & B-Cast commands on page 87](#).
- SMA** Choose this to send and receive data when using the SMA (Scale Manufacturers Association) protocol. See [SMA Protocol on page 82](#). The information will be sent through the bound port using attributes that are predefined by the SMA protocol.
- b-cASt** Choose this to send data continuously through the selected binding using the associated attributes. Typical use is for remote scoreboards, displays and the Analog output option if installed. See [ENQ & B-Cast commands on page 87](#).
- PLC** Choose this to send and receive data to/from a PLC network. A binding of Enet x (1 through 5) is required. The attributes are established using the PLC menu described later in this manual. See [PLC Configuration information on page 90](#).
- FtP** Choose this to send data via FTP. A binding of Enet x (1 through 5) is required. The Rate attribute determines the time (in minutes) between attempted FTP updates. A second Protocol is required to complete the FTP setup. This additional protocol requires a Type x = PRINT, Bind x = File and Attributes x will need a Print Format. Also, set File Path = FTP and define the File Mode (File naming convention) in the File menu described later in this manual.
- rd** Choose this to use the indicator as a remote display. When set as a remote display, the indicator will only function as a remote display for the connected primary indicator which is connected to the weighing platform.

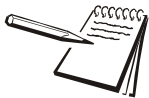

RD (remote display) requires selection of a port for Binding to the primary display. Choices include Port 1, Port 2 or E-Net 1 through 5. Contact your local Avery Weigh-Tronix representative for information on setting up the indicator as a Secondary indicator.

- nci** Choose this to use the NCI communication protocol. See [NCI commands on page 88](#).
- rEPortS** Choose this for reports using footers and headers.
- bSq** Choose this when using a BSQ base.

intPrt This stands for input interpreter. Choose this when using macros. **This can only be configured via Ztools.** See the warning below.



WARNING: If using Input Interpreter, do NOT change to another TYPE from the front panel or Input Interpreter will not be available without reconfiguring from Ztools.

- Bind x -** In this item you choose the physical connection, or hardware, for the communication for Protocol x: **Port 1-2, EnEt 1** through **EnEt 5, FiLE, oPtion, Prtr 1, Prtr 2** or **Prtr.uSb**. Some Bindings will not apply for certain Type selections.
- Attr x-** In this item you choose the print format and other properties that are required for the Type and Binding selected for Protocol x. Some attributes will not apply for certain Types or Binding combinations.
- PrnFt,** Choose a print format from the documented list. Key in the format number. Print format **1** is the default.
- inhib** This is motion inhibit. Choose **on** to enable or **oFF** to disable. If enabled, data transmission or file creation will be inhibited until there is no motion on the scale or until the process times out. **oFF** is the default.
- rAtE** This is the transmit rate associated with broadcast type. Choices are **1, 2, 5, 10, 20, 50, 80** or **100** Hz.
- AddrESS** Key in the node address if using an RS-485 option in a multidrop network. Choices are **1** to **254**.
- Enq** Key in the enquire character used to request a print function to occur from the communications port. Choices are **0** to **255**. **5** is the default value (ASCII ENQ character).
- Enq2** This functions the same as pressing the **PRINT** key.
- If Archive is enabled, this can be used for Archive reporting to add the transaction record and increment the counter. The default value is **7** (ASCII BEL character). Choices are **0** to **255**.
- ScALE** If multiple scales are enabled, select the scale number this attribute is assigned to.

6.5.4 P.F.Edit

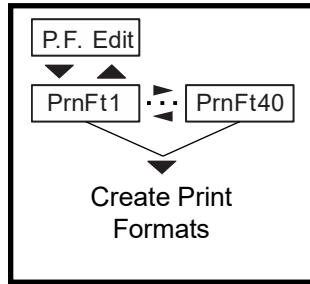

P.F.Edit This stands for print format editor. Please refer to the section [Print formatting on page 109](#) for the procedures to edit or create print formats.

6.5.5 PLC

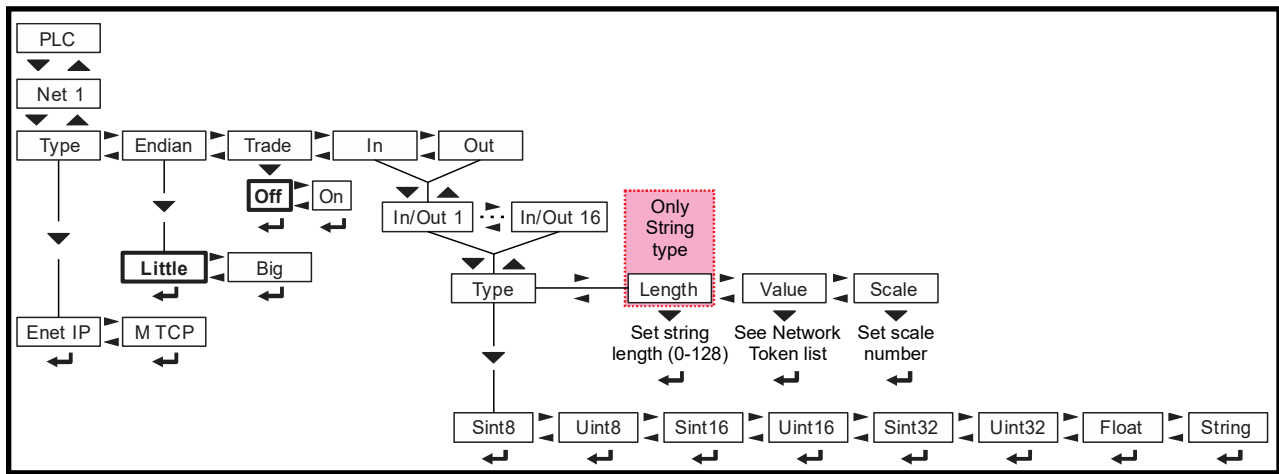

If connecting to a PLC, the E-NET configuration menu does not require any special configuration and the Client/Server selection for TYPE setting must be set to OFF.

nEt 1 This is an item for future expansion to multiple networks. This is not available on this indicator. Continue to the next item.

tYPE In this item you can choose; **EnEt iP** or **M tcP**. Choose **EnEt iP** to enable Ethernet IP. Choose **M tcP** to enable Modbus-TCP.

EndiAn Choices for this item are **big** or **LittLE**. Default is **LittLE**.



ENDIAN:
Big = Most Significant Byte, Least Significant Byte
Little = Least Significant Byte, Most Significant Byte

trAdE This stands for word swap or trade configuration. Choices for this item are **on** or **oFF**. Default is **oFF**.



TRADE: On = WORD2,WORD1
Off = WORD1,WORD2



The PLC configuration determines the appropriate indicator settings for Endian and Trade.

in This stands for inbound data configuration. You will first select one of the 16 memory registers available for inbound data. Then you will select the data type and then the network token you want assigned to that memory register.

in 1-16 These are the 16 inbound data configuration memory registers.

tyPE Below is a table showing the choices for the Type, a description and a range of values for that data type.

Type	Description	Range of Value
SINT8 - 1 byte	Signed Character	-127 to 127
UINT8 - 1 byte	Unsigned Character	0 to 255
SINT16 - 2 bytes	Signed Integer	-32767 to 32767
UINT16 - 2 bytes	Unsigned Integer	0 to 65535
SINT32 - 4 bytes	Signed Long	-2,147,483,647 to 2,147,483,647
UINT32 - 4 bytes	Unsigned Long	0 to 4,294,967,295
Float - 4 bytes	Floating Point	1.0×10^{-37} to 1.0×10^{37}
Double - 8 bytes	Double precision floating point	1.0×10^{-1023} to 1.0×10^{1023}

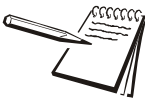

The Type and order of the Values selected must coincide with the configuration of the PLC register setup. Consult with the site IT specialist.

LEngth Set the string length. Values from 0-128 acceptable.

VALuE This stands for the network token value to be assigned to the inbound data memory register. Key in the value for the network token you want from the table above and press **ZERO** to accept the displayed choice ...

Repeat the process for any other inbound memory registers you want to configure.

ScALE Choose from connected scales.

out This stands for outbound data configuration. This menu item is exactly like the **in** menu item except it is for outbound data. Follow the same process to set up the 16 memory registers.

6.5.6 Printer

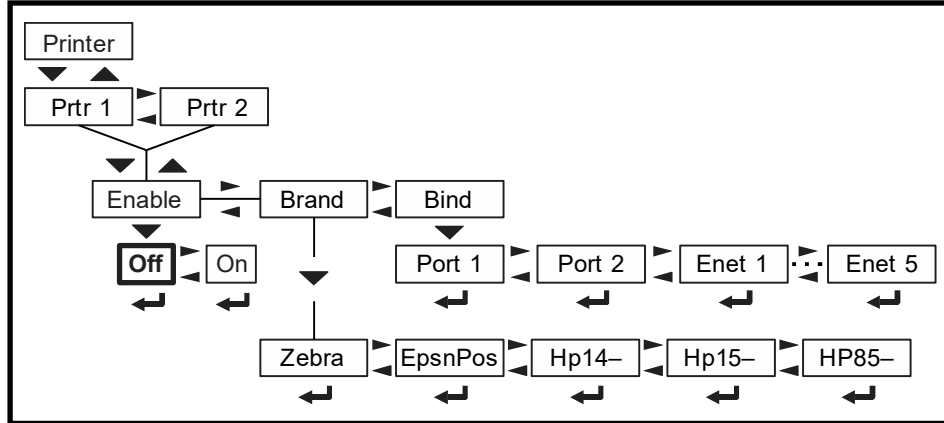

The **PrintEr** menu is used when the indicator is interfaced with one of the printers listed in the **brAnd** submenu. This is necessary to ensure all the appropriate control codes are added to the selected print format.

If either **PRTR1** or **PRTR2** selections are enabled then the port that is **Binded** may occasionally send out a set of random characters to test for a connected printer. Be sure to disable these settings if the indicator is not connected to one of the printer brands listed.

- Ptr 1** You can choose to set up this printer or **Ptr 2**. The setup procedure is the same.
- EnAbLE** Choices under this item are **oFF** (default) or **on**.
- brAnd** Choices under this item are the five printer models supported by this indicator: **ZEbrA**, **EPsnPoS**, **hP 14--**, **hp15--** and **hp85--**.
- bind** Choices under this item are: **Port 1**, **Port 2** and **EnEt 1** through **EnEt 5**. Choose which port the printer output is attached to.

6.5.7 File

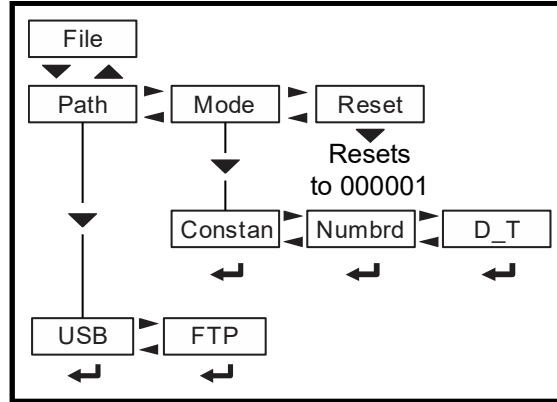

FILE Use this item to configure how and where files are saved.

Path Use this to choose where the file is saved, internally for transfer by **FtP** using an Ethernet port or to a connected **uSb** flash drive.

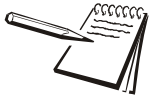

When the **FILE > PATH** is set for **USB**, a **USB** flash drive can be installed into the **USB** Host port and transactions will be transferred to the flash drive as they occur. If the flash drive is not installed, transactions will be saved onto the Flash memory in the indicator.

The size of the print format will determine the number that can be stored but with a typical print format the indicator should be capable of storing several thousand transactions. The saved transactions will transfer immediately when the **USB** flash drive is re-installed. The message **CoPYing** will display as each stored file is transferred to the flash drive. If using the **d_t** file mode this could take a few seconds to transfer each file. Do not remove the flash drive until the message **donE** is finally displayed. Stored transactions will then be cleared after the transfer.

ModE Use this to configure the file convention. Choices are:

conStAn This will create a single file that will be appended to as new information is saved.

nuMbrd This will create new file appended with a sequential number for each transaction.

d_t This will create a new file and the file name will be appended with the date and time (including seconds) for each transaction.



Filename Examples:

<MODEL>_<SERIAL>XXXXXX.txt

where <MODEL> is the model number, <Serial> is the serial number, XXXXXX is either nothing, the sequential number, or the time and date.

Sequential number increments from 000001 – 999999 when RESET starts at 000001

Date = YYYY_MM_DD__HH_MM_SS
with double underscore between DD and HH

Examples:

Constant: ZM400_120450001.txt

Numbered: ZM400_120450001_000001.txt

D_T: ZM400_120450001_2012_01_31__10_31_23.txt

If transactions are being store on the indicator Flash memory, only a single Constant or Numbered file will be created. If using the Date & Time file naming convention then individual files will be created.

rESEt Reset will clear all stored transactions and also reset the numbered file sequence to 000001.

6.5.8 Options

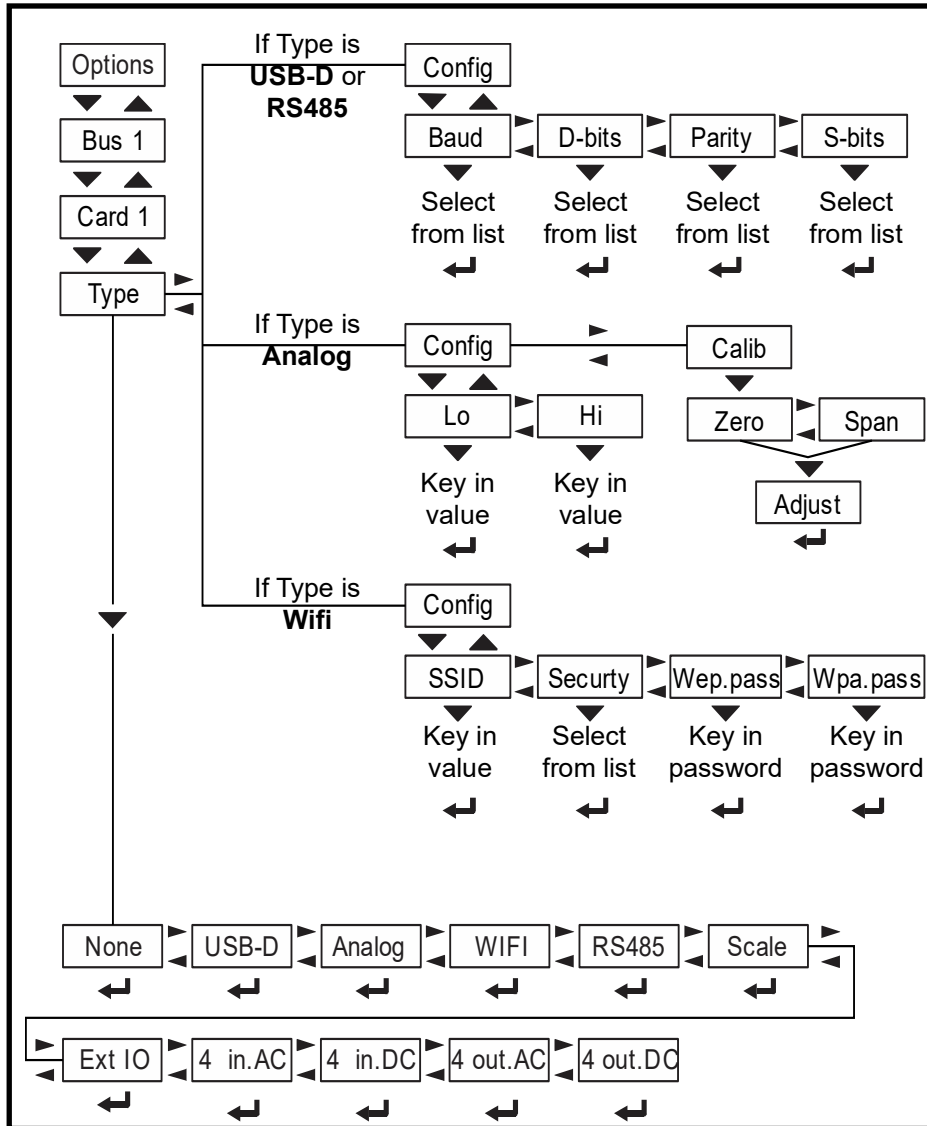

oPtions Use this parameter to enable any of the available option cards.

buS 1 There is only 1 bus available on this indicator.

cArD 1 There can only be one card at a time in this indicator.

tYPE Choose the type of card installed from this list:

- | USB-D(evice) card.
- | Analog output card
- | 802.11 wireless card (see note below)
- | Serial RS-485/20mA card

The **ScALE** menu item is for either of the next two input cards:

- | 5VDC Excitation Analog Scale Input card
- | 10VDC Excitation Analog Scale Input card

The **Ext io** menu item is for the following I/O interface card:

- | External I/O Interface card
- | AC Input 4 relays (120-240VAC) card
- | DC Input 4 relays (4-30VDC) card

- 1 AC Output 4 relays (20-240VAC) card
- 1 DC Output 4 relays (3-60VDC) card

Depending on the choice made for **tYPE**, a **conFig** menu may appear. See the Options menu on page 76. See the Options menu on page 79.

If USB-D or RS485/20ma card is installed:

Config

- bAud** Select from the list of baud rates.
- d-bitS** Select 7 or 8.
- PAritY** Select none, odd or even.
- S-bitS** Select 1 or 2 stop bits.

The Serial RS485/20ma and USB-D options require a Bind setting of **oPtion**

If Analog card is installed:

Config

- LoW** Set the displayed value for the lowest analog output.
- Hi** Set the displayed value for the maximum analog output.

cALib

- ZEro** Set the analog output zero point.
- SPAn** Set the analog output span point.
- AdJuSt** Adjustments are normally necessary to set the zero or span output values to correlate with the connected analog device. Pressing the following keys will adjust the signal output as noted.
- TARE** increase in small increments
- SELECT** decrease in small increments
- PRINT** increase in large increments
- UNITS** decrease in large increments

Press **ZERO** to complete the analog output calibration

The Analog Output requires a Bind setting of **oPtion**

If Wireless card is installed:

SSid	Use the alphanumeric entry methods described in 2.3 and 2.4 to enter a SSID network name.
SEcurtY	Select the type of security from this list: None WEP-64 WEP-128 WPA WPA2
WEP.PASS	If WEP-64 or 128 is selected use the alphanumeric entry methods described in 2.3 and 2.4 to enter a WEP security password.
WPA.PASS	If WPA or WPA2 is selected use the alphanumeric entry methods described in 2.3 and 2.4 to enter a WPA security password.

The 802.11 wireless option requires the same setup as an Ethernet port and a Bind setting of E-Net 1 thru 5 based on the Ethernet setup.

If External I/O card is installed:

GSE Select GSE for GSE 16 Position I/O Setpoint Option card.

1310 Select 1310 for 1310 16 Cutoff Expansion Board

The External I/O and AC/DC Inputs/Outputs options require Ztools to configure

This completes the service menus for the ZM400 indicator. See [Exiting the menus on page 21](#) to save the setup and return to normal weigh mode.

7 Communication port protocols

7.1 SMA Protocol

7.1.1 Level 1 and 2 Commands

Sent	Action	Response
<LF>W<CR>	Weight of the current scale is return.	Standard response (displayed weight)
<LF>P<CR>	Indicator attempts to capture a stable weight on the current scale.	Standard response (displayed weight). Weight is returned as center dashes < ----- > if a stable weight cannot be established.
<LF>Z<CR>	Indicator attempts to zero the current scale.	Standard response (displayed weight)
<LF>T<CR>	Indicator attempts to tare the current scale.	Standard response (displayed weight)
<LF>T<xxxxxx.xxx><CR>	The indicator attempts to set the current scale's tare weight to the value that was sent.	Standard response (displayed weight)
<LF>M<CR>	The indicator returns the current scale's Tare weight.	Standard response (tare weight)
<LF>C<CR>	The indicator sets the current scale's Tare weight to zero.	Standard response (gross weight)
<LF>U<CR>	The indicator will cycle the unit of measure on the current scale	Standard response (displayed weight)
<LF>U<uuu><CR>	The indicator will set the unit of measure to <uuu> on the current scale.	Standard response (displayed weight)
<LF>D<CR>	The indicator will return a diagnostic message.	<LF><r><e><c><m><CR> <r> = 'R' (RAM error) or ' ' (space) (RAM ok)
<LF>A<CR>	The indicator will respond with the first line of the About data.	See "About Command Response" (below)
<LF>B<CR>	The indicator will respond with the rest of the About data.	See "About Command Response" (below)
<LF>I<CR>	The indicator will respond with the first line of the scale Information data. (for the current scale)	See "Scale Information Command Response" (below)
<LF>N<CR>	The indicator will respond with the rest of the scale Information data. (for the current scale)	See "Scale Information Command Response" (below)
<ESC>	The indicator will reboot itself	None

SMA protocol is maintained by an external organization. For definitive and current details on this protocol go to www.scalemanufacturers.org.

7.1.2 Standard Scale Response Message

<LF><s><r><n><m><f><xxxxxx.xxx><uuu><CR>		
<LF>	Line feed	Start of the response message.
<s>	Scale Status	'Z' Center of Zero 'O' Over Capacity 'U' Under Capacity 'E' Zero Error 'T' Tare Error <space> None of the above conditions.
<r>	range	Multi-interval range. Always '1' if multi-interval is disabled.
<n>	gross/net status	'G' = Gross weight 'T' = Tare weight 'N' = Net weight
<m>	Motion status	'M' = scale is in motion <space> = scale is stable
<f>	Future use	<space> = always a space.

7.1.3 Unrecognized Command Response

<LF>?<CR>

7.1.4 About Command Response

The 'A' and 'B' commands are used together to get all of the scale about data. The 'A' command will always return the 1st response below. The 'B' command must be sent multiple times to get the 2nd, 3rd, and 4th responses. Once the 4th response is received, the next 'B' command will return an Unrecognized Command Response. At this point you would have to send another 'A' command to get the 1st response again.

<LF><xxx>:<yyyy><CR>

1st response: <xxx> = "SMA"
<yyyy> = compliance level/revision

2nd response: <xxx> = "MFG"
<yyyy> = manufacturer

3rd response: <xxx> = "MOD"
<yyyy> = software part number

4th response: <xxx> = "REV"
<yyyy> = software revision

7.1.5 Scale Information Command Response

The 'I' and 'N' commands are used together to get all of the scale information data. The 'I' command will always return the 1st response below. The 'N' command must be sent multiple times to get the 2nd, 3rd, 4th, 5th, and 6th responses. Once the 6th response is received, the next 'N' command will return an Unrecognized Command Response. At this point you would have to send another 'I' command to get the 1st response again.

<LF><xxx>:<yyyy><CR>

1st response: <xxx> = "SMA"
<yyyy> = compliance level/revision

2nd response: <xxx> = "TYP"
<yyy> = 'S'

3rd response: <xxx> = "CAP"
<yyyy> = uu:ccc:n:d where
uu = unit of measure
ccc = capacity of the range lower range (capacity of the scale is multi-interval is disabled)
n = least significant count-by digit for this range
d = decimal point position for this range
'0' = none
'1' = xxxx.x
'2' = xxx.xx
etc.

4th response: <xxx> = "CAP"
<yyyy> = uu:ccc:n:d where
uu = unit of measure
ccc = capacity of the range upper range (4th response will not be sent if multi-interval is disabled)
n = least significant count-by digit for this range
d = decimal point position for this range
'0' = none
'1' = xxxx.x
'2' = xxx.xx
etc.

5th response: <xxx> = "CMD"
<yyyy> = "PTMCU" list of supported SMA commands.
Level 1 commands are not included in the list.

6th response: <xxx> = "END"
<yyyy> = nothing

7th & more -
responses: Subsequent N commands will return a '?' response. Unrecognized Command Response

7.1.6 Avery Weigh-Tronix Extended SMA Commands



AWT Extended SMA command/response protocol allows use of the same Network Tokens shown in [ATTRIBUTE: 3 hex on page 92](#).

<LF>XA<CR>

This will initiate an Accumulate command. If the indicator is in ACCUM or COUNT app it will perform an Accumulation transaction if all required conditions are met.

The command will also perform the same function as pressing the **PRINT** key on the front panel. Response will be to any communication ports that are binded to a Type = Print. The port that initiated the command will also receive an <LF>xa<CR> response.

<LF>XB<CR>

This will initiate a PRINT command. The command will also perform the same function as pressing the **PRINT** key on the front panel.

No response.

<LF>XK<CR>

This will return a list of up to the last twenty keys pressed. The buffer is cleared after this command.
<LF>Xk:Y<CR> where Y is:

- T for TARE key
- S for SELECT key
- Z for ZERO key
- P for PRINT key
- U for UNITS key
- F for F1 key
- G for START key
- H for STOP key
- I for ID key
- L for TARGET key
- J for SAMPLE key
- K for SETUP key
- C for CLEAR
- R for REPORT key
- Q for IN/OUT key
- E for FLEET key
- . for Decimal key
- # for all numeric keys



The list above includes all the keys for all the various models of Z indicators. If your model of indicator does not have one of these keys, that key will not be included in the returned list.



XD, XZ and XS commands, below, only work if the indicator is unsealed.

<LF>XC<CR>	This will return the audit counters in this format: <LF>Calib:xxx:Config:yyy:<CR>
<LF>XD<n><CR>	This will initiate the resetting of the calibration and/or configuration parameters depending on the format chosen from the list below: If n=1, reset config only If n=2, reset calibration only If n=3, reset both The response will be in the form of: <LF>xd<n><CR>
<LF>XZ<CR>	This will initiate a Cal Zero command. The scale responds with a standard scale response message, with one additional custom status response added. If the "Set Zero" operation fails then the scale responds with the <s> field = "0"
<LF>XS<www><CR>	This will initiate a Cal Span command where <www> is the weight used to calibrate with. The scale responds with a standard scale response message, with one additional custom status response added. If the "Set Span" operation fails then the scale responds with the <s> field = "s"
<LF>XVS<n>:<value><CR>	The indicator will set the <value> of the variable specified by the Network token. A valid XVS command will receive a response of <LF>xvs<CR>. To verify an XVS command was successful requires sending the XVG command to confirm the value of the variable.
<LF>XVG<n><CR>	The indicator will get or return the value of the variable specified by the network token. A valid response is in the form of <LF><value><CR>.

7.2 ENQ & B-Cast commands

A	ACCUM command	"If ACCUM APP is active this command will generate an accumulation transaction, but it does not perform the print function"
P	PRINT command	"Performs same function as pressing the PRINT key. All Ports that are binded with PRINT type will transmit the assigned print format"
S	SELECT command	Performs same function as pressing the SELECT key
T	TARE command	Performs same function as pressing the TARE key
U	UNITS command	Performs same function as pressing the UNITS key
Z	ZERO command	Performs same function as pressing the ZERO key
F	F1 command	Performs same function as pressing the F1 key
I	ID command	Performs same function as pressing the ID key
O	OVER command	Performs same function as pressing the OVER key
N	UNDER command	Performs same function as pressing the UNDER key
L	TARGET command	Performs same function as pressing the TARGET key



Upper or lower case characters will perform the same function.

7.3 NCI commands



Refer to the NCI Standard Document (AWTX Control Document SCP-01) for complete details on NCI command protocol. This is available on the www.averyweigh-tronix.com website. Search for SCP-01 on the website.

W <Cr>	Weight request	Returns decimal weight, units and status
S <Cr>	Status request	Returns status.
Z <Cr>	Zero request	Scale is Zeroed and returns scale status.
H <Cr>	High Resolution Weight request	Returns decimal wt in 10x or x100 resolution with units and status. For x100 resolution set the associated PROT > ATTR > ENQ menu value to 100. For all other values the H command will return x10 resolution
U <Cr>	Units request	Changes unit of measure and then returns decimal weight in the new units with status.
M <Cr>	Metrology Raw Counts request	Returns normalized raw counts and scale status.
T <Cr>	Tare request	Scale is Tared and returns scale status.
all else	Unrecognized command	Returns <Cr> ? <Lf>



See [Additional token tables on page 126](#) for status byte information.



If the PROT > ATTR > ENQ menu value is set to 100, to increase resolution by 100, you may add a 2 or 3 to the command to return a 2 or 3 character status byte. For example: 102 will increase resolution by 100 and return a 2 character status byte.

7.4 R-Disp commands

Incoming commands from the Master indicator that control the Remote display annunciators		
G	Gross	Change to Gross weight mode
N	Net	Change to Net weight mode
T	Tare	Change to Tare weight mode
l	lb	Change to lb
k	kg	Change to kg
O	oz	Change to oz
g	grams	Change to grams

Outgoing key press commands from the Remote display that control the Master indicator operation	
T	TARE
S	SELECT
Z	ZERO
P	PRINT
U	UNITS
F	F1

Key press commands are supported by COM Port 1 and 2 only.

7.5 PLC Configuration information



If connecting to a PLC there are required configuration settings in the **SETUP > PORTS** menu.

In the **PROTCL** menu set **TYPE x = PLC** and **BIND x = Enet x**

In **E-NET** menu you must configure the proper network IP address settings in **IP ADDR**, set **DHCP = OFF** (PLC's are not DHCP reliant), and **CONN > E-NET x > TYPE x = OFF** (PLC's do not use Client/Server topology)

In **PLC** menu configure the settings as required for the connected PLC network.

At the PLC select the size that matches the number of bytes for each item configured in the indicators data type setting. If possible use the same data type for all data.

DATA TYPE TABLE		
Typical PLC Terminology	Indicator Terminology	Data TYPE Size
CHAR / SBYTE	SINT8	8 Bits (Signed Value / -127 to 127)
BYTE / UBYTE	UNIT8	8 Bits (Unsigned Value / 0-255)
SHORT / SINT	SINT16	16 Bits (Signed Value /-32767 to 32767)
WORD / UINT	UNIT16	16 Bits (Unsigned Value / 0 to 65535)
LONG / SDINT	SINT32	32 Bits (Signed Value / -2,147,483,647 to 2,147,483,647)
DWORD / UDINT	UNIT32	32 Bits (Unsigned Value / 0 to 4,294,967,295)
REAL	FLOAT	32 Bits (Signed Decimal Value / 1.0E-37 to 1.0E37)

7.5.1 ModBus/TCP

Starting Register Locations for PLC Configuration

To PLC → Input Read Only 30001 (Mirrored at the Read/Write Locations)
 → Input Read/Write 40001 (i.e. Gross, Net, etc.)
 From PLC → Output Read/Write 41025 (i.e. PB-Zero, Print, etc.)

2 Byte Example	
Indicator Data Type (out)	ModBus Register
SINT16	40001
SINT16	40002

4 Byte Example	
Indicator Data Type (out)	ModBus Register
SINT32	40001
SINT32	40003

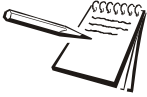

Note each register holds 2-bytes or 1-word. If a 4-byte or 2-word data type is used 2-registers are required for each item. This makes the starting register number for each item skip a register number between items.

7.5.2 Ethernet/IP Implicit Messaging:

AWTX Assembly Instance and Size

	Assembly Instance	Size
Input	100	Refer to the number of items configured for Out Configuration at the indicator
Output	112	Refer to the number of items configured for In Configuration at the indicator
Configuration	128	0

INPUT/OPUTPUT SIZE: Is the number of elements (items) configured in the indicator for the data IN and OUT not the number of bytes.

7.5.3 Ethernet/IP Explicit Messaging:

AWTX Indicator Input Point Object (PLC Data Out)

CLASS: 64 hex

ATTRIBUTE: 3 hex

PLC Instance	Supported services for this attribute (hex value)	Data Type	Indicator Input (In) Configuration Data
Data Element Location 1= First Element 2=Second Element	0 x 10 (Set Attribute Single)	Based on network configuration in indicator. See DATA TYPE TABLE	1-16 (Bound to the instance x)

AWTX Indicator Output Point Object (PLC Data in)

CLASS: 64 hex

ATTRIBUTE: 3 hex

PLC Instance	Supported services for this attribute (hex value)	Data Type	Indicator Output (Out) Configuration Data
Data Element Location 1= First Element 2=Second Element	0 x 0E (Get Attribute Single)	Based on network configuration in indicator. See DATA TYPE TABLE	1-16 (Bound to the instance x)

8 Option cards

The ZM400 has several option cards available. Only one card can be installed in the indicator. This chapter covers the description and installation of these cards:

- 1 [Analog output card on page 94](#)
- 1 [Current Loop/RS485/RS422 card on page 95](#)
- 1 [USB Device option card on page 96](#)
- 1 [Wireless Ethernet communication \(802.11g\) card on page 97](#)
- 1 [Internal 120 VAC relay card \(for IP69K only\) on page 98](#)
- 1 [2nd Scale Input 5VDC Excitation card on page 100](#)
- 1 [2nd Scale Input 10 VDC Excitation w/STVS card on page 101](#)
- 1 [External I/O Interface card on page 102](#)
- 1 [AC input, 4 Inputs \(120-240VAC\) card on page 103](#)
- 1 [DC input, 4 inputs\(4-30VDC\) card on page 104](#)
- 1 [AC output, 4 relays \(20-240VAC\) card on page 105](#)
- 1 [DC output, 4 relays \(3-60VDC\) card on page 106](#)



On all the option cards, S1 switch settings must all be OFF to operate.

Below is an example of an option card. All the option cards connect to the main board by the connector pins on the bottom of the option card to the connector at terminal J4. Screws, at the four locations noted by the arrows, hold the board in place.

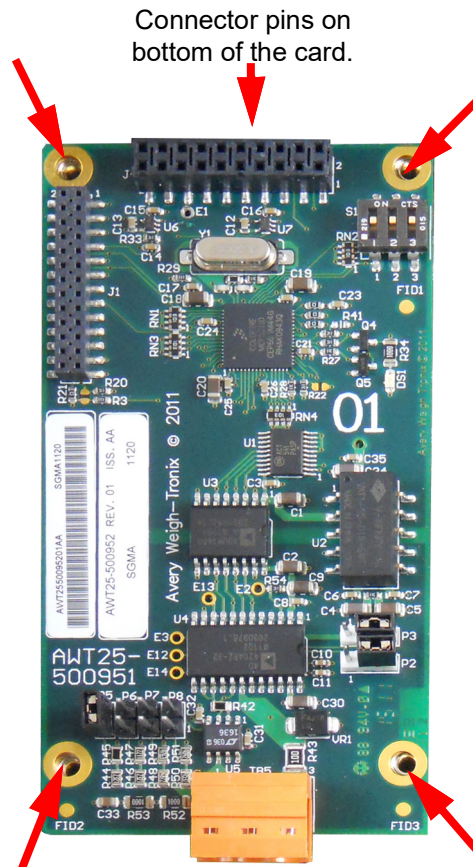
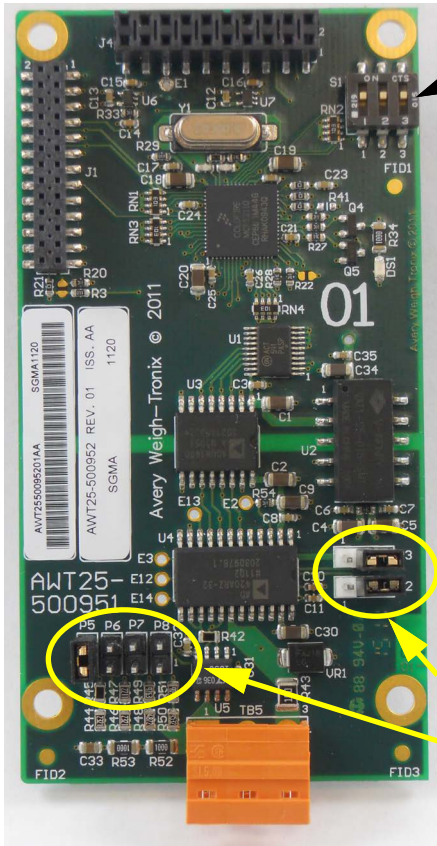

Figure 8.1 Option card example

8.1 Analog output card

Figure 8.2 shows the analog output card. This provides analog output in proportion to the weight on the scale. See [Options on page 79](#) for information on configuring the indicator and this card.



S1 switch settings must all be OFF to operate.

The analog output card uses a 16 bit A/D with resolution capabilities of 65,536 divisions.

Analog Output Chart							*Load Resistance
Types of Output	P2	P3	P5	P6	P7	P8	
4 to 20MA	1-2	2-3	1	1	1	1	500 Ohm Max.
0 to 20MA	2-3	1-2	1	1	1	1	
0 to 24MA	1-2	1-2	1	1	1	1	
0 to 5V	2-3	2-3	1-2	1	1	1	800 Ohm Min.
0 to 10V	2-3	2-3	1	1-2	1	1	
±-5V	2-3	2-3	1	1	1-2	1	
±-10V	2-3	2-3	1	1	1	1-2	

*Load Resistance = Cable resistance plus resistance of input unit.

Figure 8.2 Analog output option card



CAUTION: The output will run to the minimum value when a fault occurs and when you enter the Setup menus, so plan accordingly!

TB5	
Pin	Function
1	V out
2	Common (GND)
3	I out

8.2 Current Loop/RS485/RS422 card

Figure 8.3 shows the Current Loop/RS485/RS422 option card. This provides Current Loop/RS485/RS422 communication to and from connected devices. See [Options on page 79](#) for information on configuring the indicator and this card.

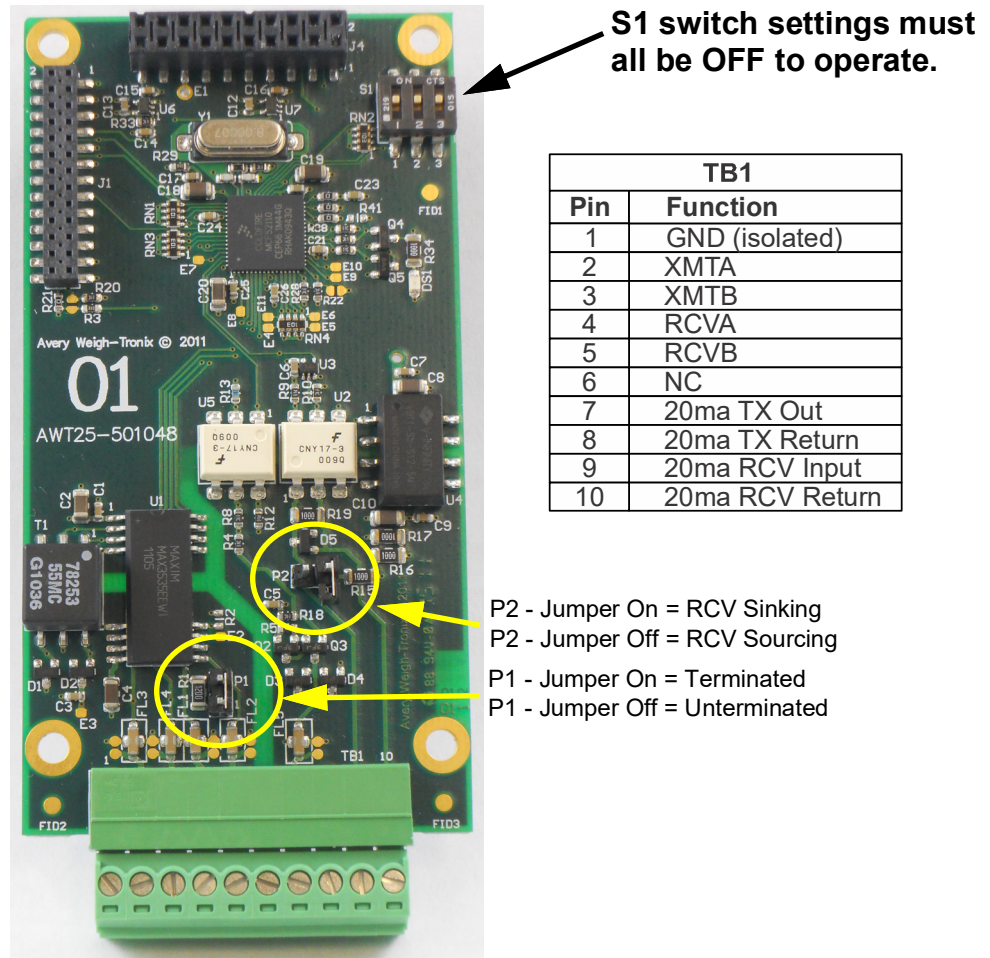

Figure 8.3 Current Loop/RS485/RS422 card

8.3 USB Device option card

Figure 8.4 shows the USB Device option card. This provides connection for a USB host device. See [Options on page 79](#) for information on configuring the indicator and this card.

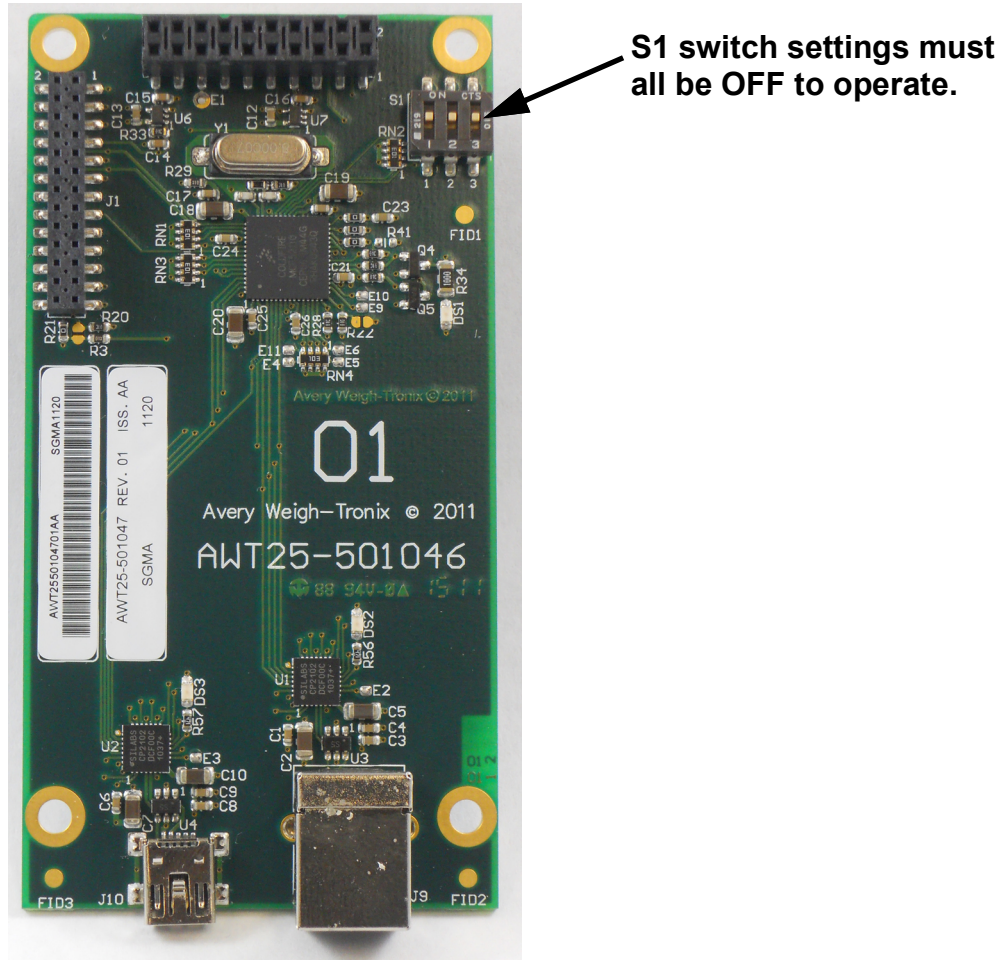

Figure 8.4 USB Device option card



Driver required when connected to a PC. Download driver from the password protected portion of www.wtxweb.com.

After installing the driver, when the USB Device port is connected to a USB port on the PC it creates a Virtual COM Port (VCP). Be sure to make note of the COM port number assigned to the VCP when setting up the serial communication application.

Connections to USB Device option card include USB Type B and Mini connectors.

8.4 Wireless Ethernet communication (802.11g) card

Figure 8.5 shows the Wireless Ethernet communication 802.11g card. This provides wireless Ethernet connectivity via the 802.11g protocol..

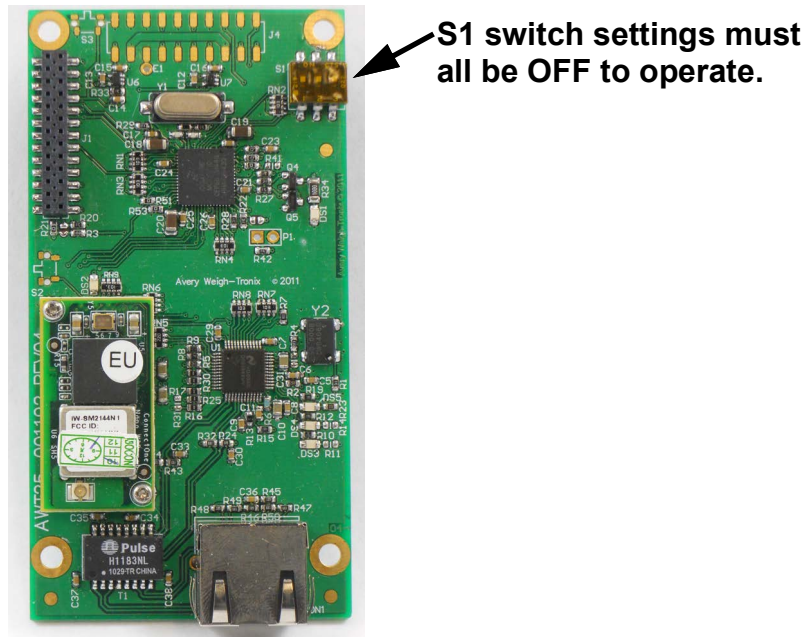

Figure 8.5 802.11g wireless communication option card

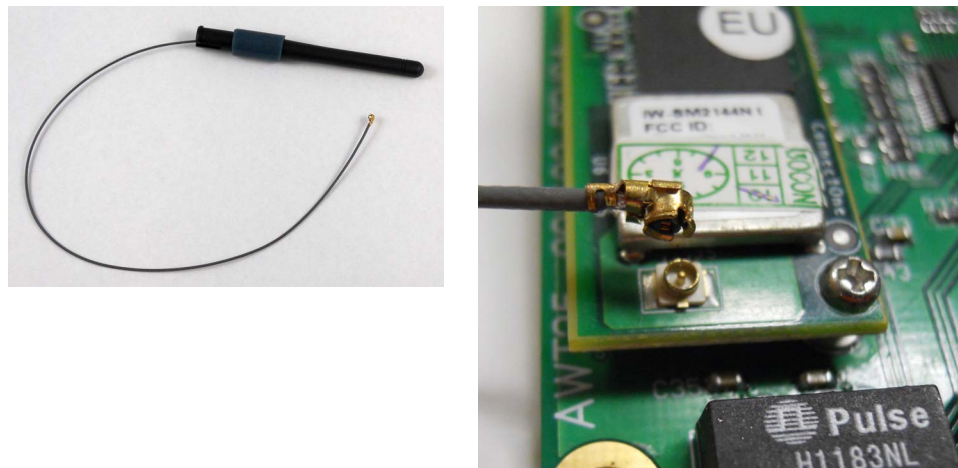

Figure 8.6 802.11g wireless communication antenna and connection point

8.5 Internal 120 VAC relay card (for IP69K only)

The AC relay converts three logic level outputs into AC solid state relays internal to the indicator. The AC relay card is shown in [Figure 8.7](#).

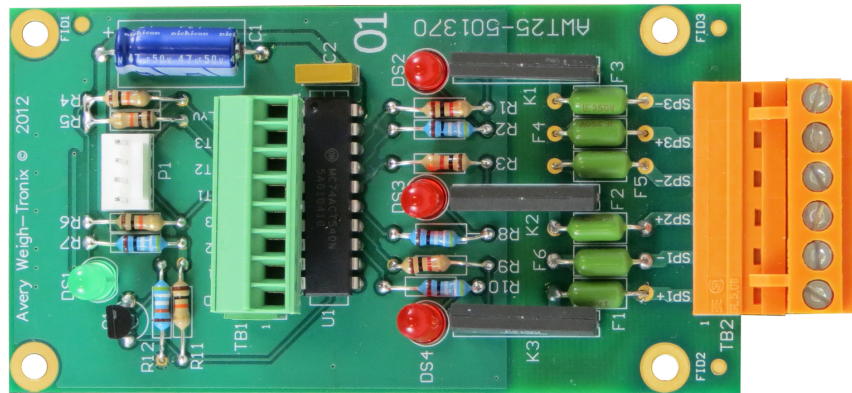

Figure 8.7 AC relay option card

8.5.1 Specifications

Output Channels (all positions)	Switched AC
Maximum output voltage	120V rms
Minimum output voltage	20V rms
Maximum output current	1A rms
Minimum output current	5mA rms
Maximum off-state voltage	400V peak
Maximum off-state leakage current	1mA rms
Maximum power dissipation	1.6 W
Load power factor for guaranteed turn-on	0.25



If the device to be controlled does not fall within these standards it is suggested that you use a mechanical relay for absolute circuit open and/or closure with appropriately rated contacts for the loading characteristics of the device.



WARNING: Risk of Electrical Shock. Insure power is removed from the indicator before installing the option card.

This option card is capable of switching up to 1Amp Max. per channel at 20-120VAC.

Please refer to the appropriate National Electrical Code regulations with regards to the switched AC mains voltage wiring sizes and insulation requirements.

8.5.2 Installing the option card

1. Plug the option card into terminal J4 on the main board. See [Figure 8.8](#). Use the included standoffs and screws to fasten the card to the main board at the four locations noted by the arrows.

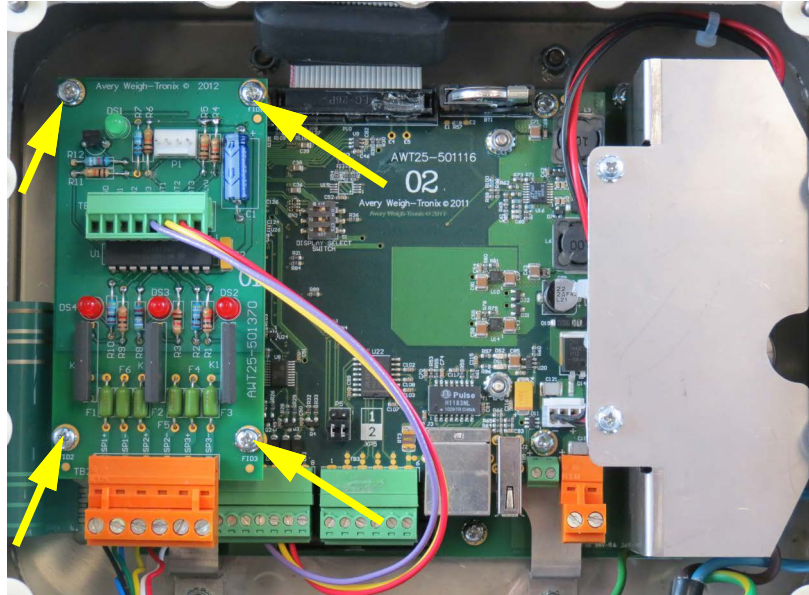

Figure 8.8 AC Relay option card on main board

2. Attach 22AWG min. wires between the:
 - Option card TB1 pin 5 (OUT1) and the Main Board TB2 pin 5 (OUT1) : SP1
 - Option card TB1 pin 6 (OUT2) and the Main Board TB2 pin 6 (OUT2) : SP2
 - Option card TB1 pin 7 (OUT3) and the Main Board TB2 pin 7 (OUT3) : SP3
 These wires are shown in place in [Figure 8.8](#).
3. The use of Ztools is typically required to configure the AC Relay option card

8.6 2nd Scale Input 5VDC Excitation card

This card allows you to connect a second analog scale with 5VDC excitation.

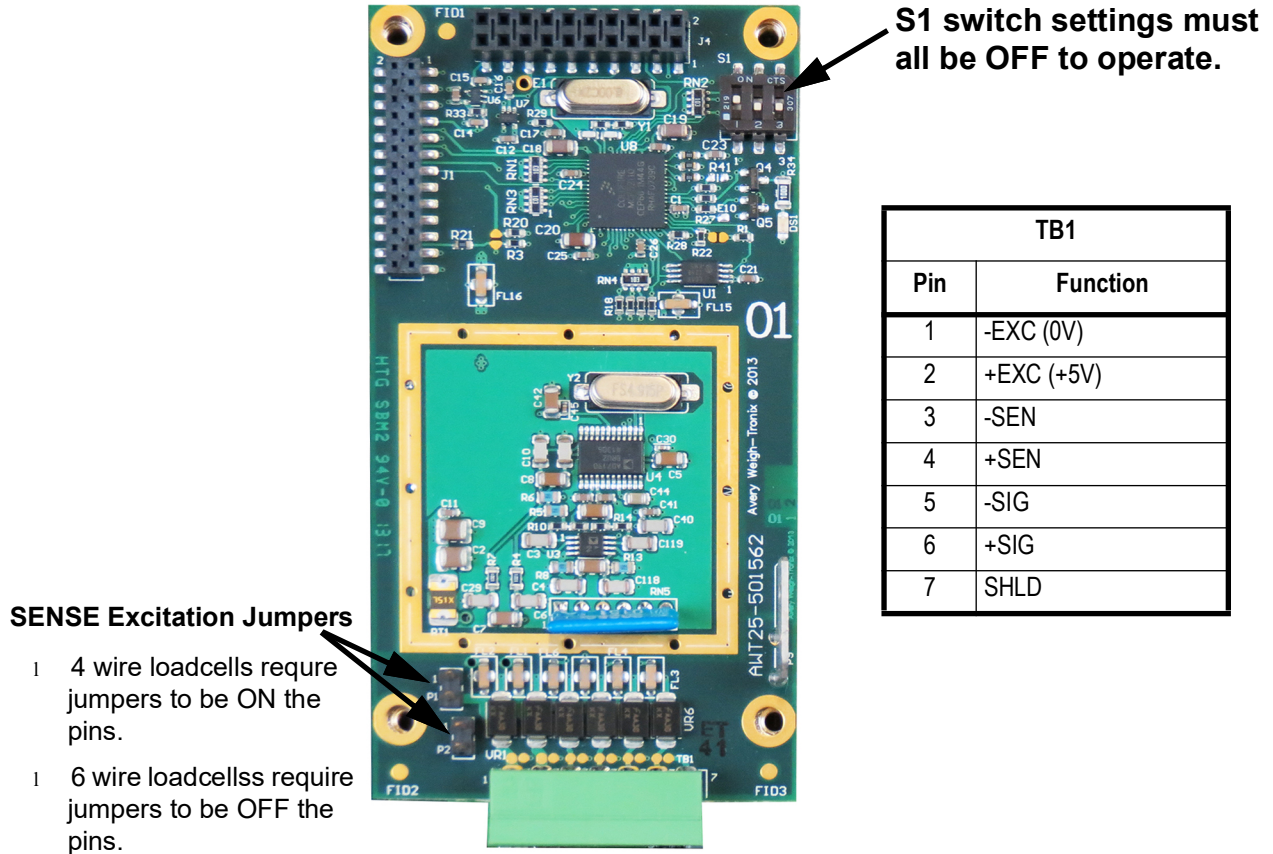

Figure 8.9 5VDC Excitation Analog Scale Input option card

8.7 2nd Scale Input 10 VDC Excitation w/STVS card

This card allows you to connect a second analog scale with 10VDC excitation.

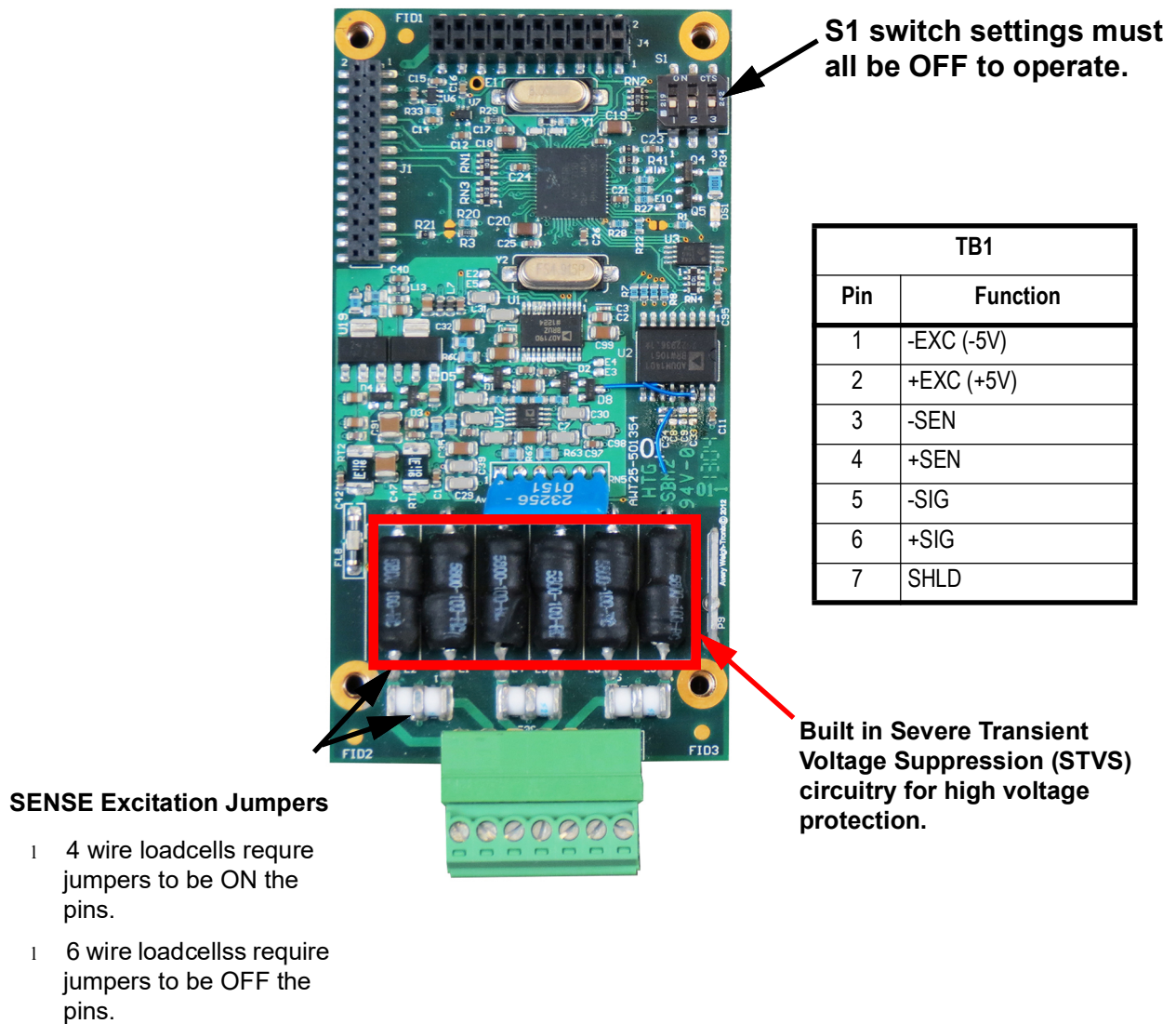
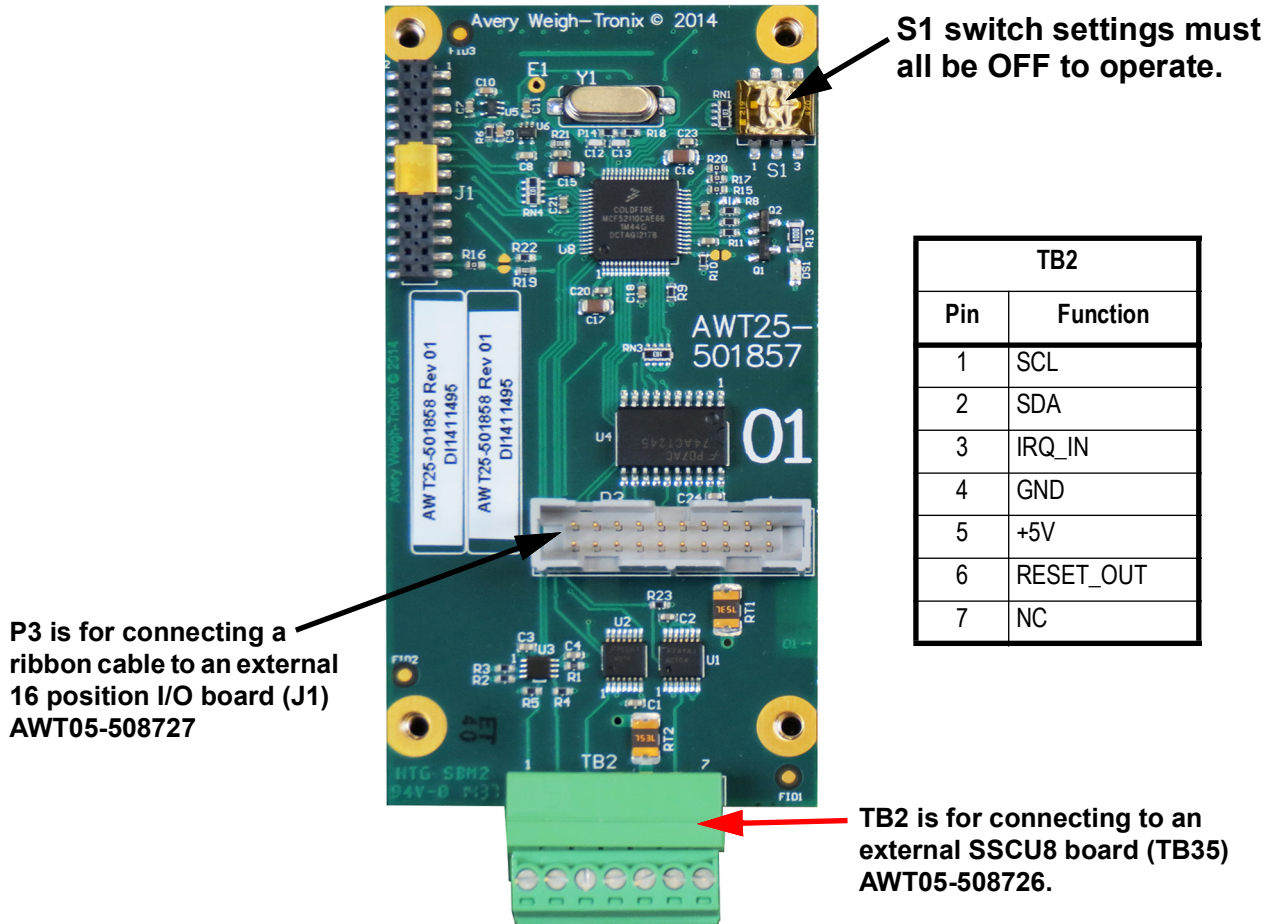

Figure 8.10 10VDC Excitation Analog Scale Input option card

8.8 External I/O Interface card

This card allows you to connect to an external I/O interface. This card is required if you are using the SSCU8 board (AWT05-508726) or the 16 Position I/O board (AWT05-508727)..



The use of Ztools is required to configure the External I/O option card.

8.9 AC input, 4 Inputs (120-240VAC) card

This card allows the connection of up to four 120-240VAC inputs.

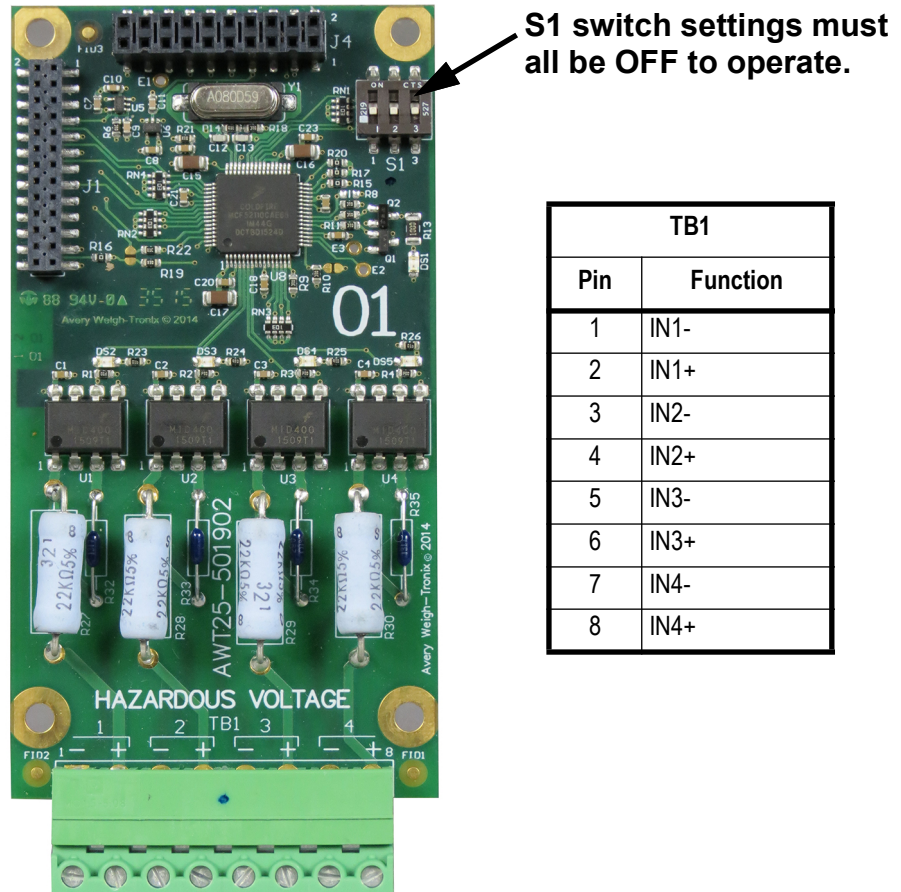
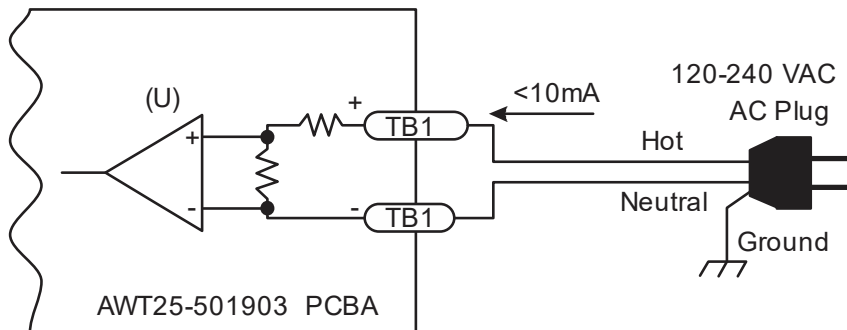

Figure 8.11 AC 4 Input card



CAUTION: For safety reasons the AC Input option card can only be used in the primary earthed stainless steel enclosure.



The use of Ztools is required to configure the AC Input option card.

8.10 DC input, 4 inputs(4-30VDC) card

This card allows the connection of up to four 4-30VDC inputs.



S1 switch settings must all be OFF to operate.

TB1	
Pin	Function
1	IN1-
2	IN1+
3	IN2-
4	IN2+
5	IN3-
6	IN3+
7	IN4-
8	IN4+

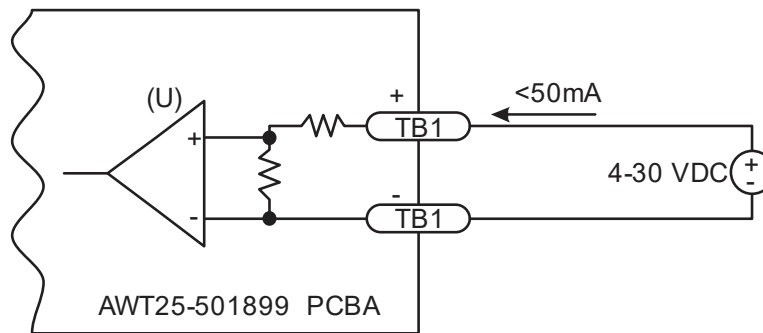

The use of Ztools is required to configure the DC Input option card.

8.11 AC output, 4 relays (20-240VAC) card

This card allows you control up to four 20-240VAC output solid state relays. Each output is rated for 1 Amp with internal fuses.

Specifications

Output Channels (all positions)	Switched AC
Maximum output voltage	240V rms
Minimum output voltage	20V rms
Maximum output current	1A rms
Minimum output current	5mA rms
Maximum off-state voltage	500V peak
Maximum off-state leakage current	1mA rms
Maximum power dissipation	1.6 W
Load power factor for guaranteed turn-on	0.25

If the device to be controlled does not fall within these standards it is suggested that you use a mechanical relay for absolute circuit open and/or closure with appropriately rated contacts for the loading characteristics of the device.

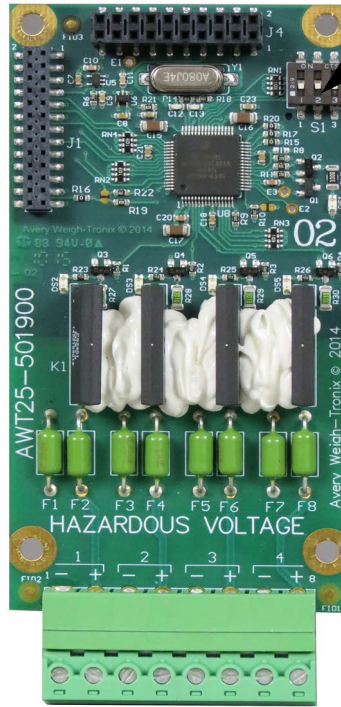

S1 switch settings must all be OFF to operate.

TB1	
Pin	Function
1	SP1-
2	SP1+
3	SP2-
4	SP2+
5	SP3-
6	SP3+
7	SP4-
8	SP4+



CAUTION: For safety reasons the AC output option card can only be used in the primary earthed stainless steel enclosure.

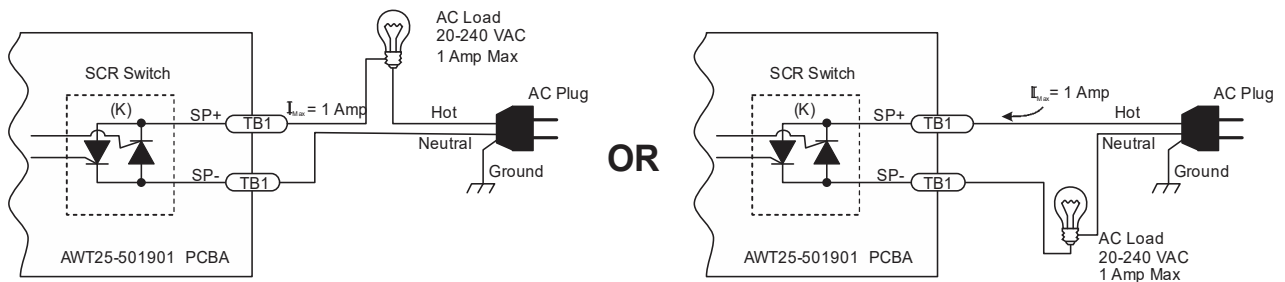
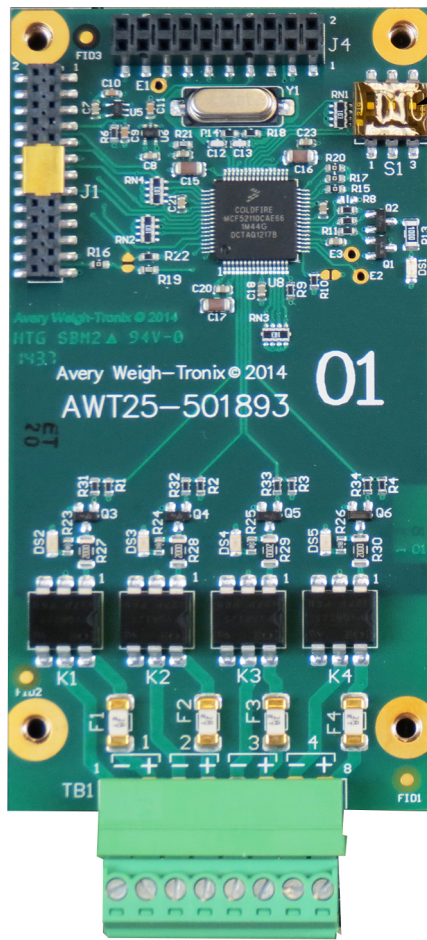

Figure 8.12 Wiring examples

The use of Ztools is required to configure the AC Output option card.

8.12 DC output, 4 relays (3-60VDC) card

This card allows you control up to four 3-60VDC output solid state relays. Each output is rated for up to 2 Amps with internal fuses.



S1 switch settings must all be OFF to operate.

TB1	
Pin	Function
1	SP1-
2	SP1+
3	SP2-
4	SP2+
5	SP3-
6	SP3+
7	SP4-
8	SP4+

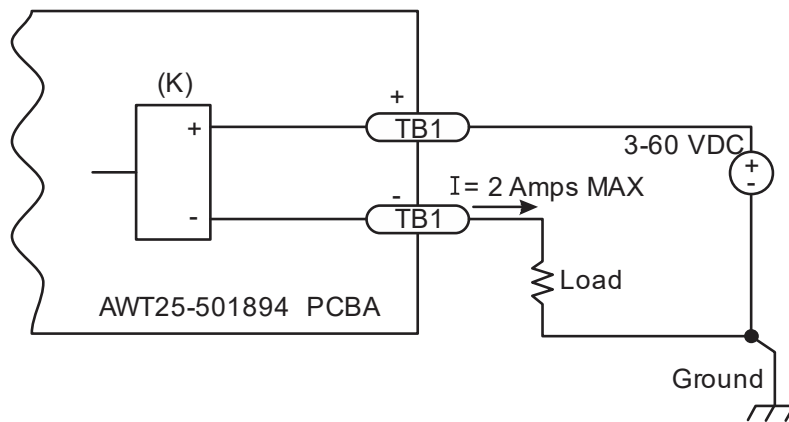

Figure 8.13 Wiring example

The use of Ztools is required to configure the DC Output option card.

9 Printed reports

Below are examples of a Configuration report, a Calibration report and an Audit report.

9.1 Configuration report

Below is a partial sample printout of a configuration report.

Parameter	Value	Data Type
SCALE_1_STABILITY_DIV	3	DOUBLE
SCALE_1_STABILITY_TIME	1	DOUBLE
SCALE_1_AZT_DIV	3	DOUBLE
SCALE_1_AZT_TIME	1	DOUBLE
SCALE_1_ZERO_RANGE	100	DOUBLE
SCALE_1_OVER_CAP_BASIS	0	ENUM
SCALE_1_OVER_CAP_DIV	9	INTEGER
SCALE_1_OVER_CAP_PER	105	DOUBLE
SCALE_1_UNDER_CAP_DIV	250	INTEGER
SCALE_1_UNDER_CAP_PER	20	DOUBLE
SCALE_1_CZERO	0.25	DOUBLE
SCALE_1_GZERO_BAND	10	INTEGER
DISPLAY_SEPARATOR	0	ENUM
DISPLAY_UPDATE_RATE	10	INTEGER
SITE_ID	SiteId	STRING
CALIBRATION_PASSWORD	2580	INTEGER
COM1_BAUD_RATE	9600	INTEGER
COM1_DATA_BITS	8	INTEGER
COM1_PARITY	0	ENUM
COM1_STOP_BITS	0	ENUM
COM1_CONTROL	0	ENUM

etc.

9.2 Calibration report

CALIBRATION REPORT

Parameter	Value
SCALE_1_ZERO_COUNTS	Value = 255037
SCALE_1_LIN_FACTOR_1_WT	Value = 0.00000000
SCALE_1_LIN_FACTOR_1_CNT	Value = 0
SCALE_1_LIN_FACTOR_2_WT	Value = 0.00000000
SCALE_1_LIN_FACTOR_2_CNT	Value = 0
SCALE_1_LIN_FACTOR_3_WT	Value = 0.00000000
SCALE_1_LIN_FACTOR_3_CNT	Value = 0
SCALE_1_SPAN_FACTOR	Value = 0.00000909
SCALE_1_GRAVITY	Value = 9.8043
SCALE_1_ZERO_MV	Value = 0.38003510
SCALE_1_SPAN_MV	Value = 1.63769878
SCALE_1_ALTITUDE	Value = 0.00000000
SCALE_1_LATITUDE	Value = 0.00000000
SCALE_1_SPAN_COUNTS	Value = 1099040
SCALE_1_CAL_WEIGHT	Value = 10.0000000
UNIT SERIAL NUMBER	Value = 20120111

9.3 Audit report

AUDIT LOG REPORT			
Parameter	old value	new value	Time
PROTOCOL_1_TYPE	0	1	2012-03-20 10:12:30
SCALE_1_UNIT3	2	4	2012-03-20 10:08:17
PROTOCOL_1_TYPE	1	0	2012-03-20 10:00:27
PROTOCOL_2_FORMAT_1	1	40	2012-03-20 09:14:45
SCALE_1_UNIT4	0	5	2012-03-20 09:10:35
SCALE_1_UNIT3	0	2	2012-03-20 09:10:30
SCALE_1_UNIT2	0	2	2012-03-20 09:10:27
SCALE_1_SPAN_FACTOR	0.00003265	0.00003707	2012-03-20 09:09:43
SCALE_1_ZERO_COUNTS	394685	-651448	2012-03-20 09:09:27
PROTOCOL_2_BIND	0	0	2012-03-20 09:09:14
PROTOCOL_2_TYPE	0	3	2012-03-20 09:09:12

10 Print formatting

10.1 Print Format Editor

The Print Format Editor creates custom print formats by letting you insert ASCII characters, scale tokens and variables into a print string. See [Print tokens, parameters and default print formats on page 119](#) for the ASCII characters, scale tokens and variables that can be used.

When you use scale tokens or variables, you must append a function number to the token or variable. The function number used depends on whether you want to print the Value, Name or Data Type of the token. The most common function usage is to print the token Value but in certain situations you may want to print the token Name. The token Data Type is reserved for special application usage.

You can also append optional parameters to a token or variable to modify the default behavior. For example, the optional parameters allow you to change the printed format such as the number of digits or characters, or use leading zeros instead of spaces, etc. The token that is selected will determine what optional parameters are available. See [Print tokens, parameters and default print formats on page 119](#) for a list of the optional parameter tables.

The ZM series indicator also supports the UTF-8 Unicode character set which is used for numerical HTML Coding values and to support many foreign language character sets.

- Following are tables showing the key functions in the string indexing and character editing modes. Use them for reference.

Table 1: Key Action When In The String Index Select Mode						
Action	TARE	SELECT	ZERO	PRINT	UNITS	F1
Momentary Key Press	Deletes current character	Selects the index character for editing using the key actions in Table 2	EXIT	Moves left one position in the index	Moves right one position in the index	Escape Edit mode and Abort all changes
Long Key Press	Deletes current character	Inserts new character before this point. Default character added is 32 (space)	EXIT	Page Up (Decrements index by 10)	Page Down (Increments index by 10)	Escape Edit mode and Abort all changes

After you select the index number, use the Table 2 key actions to edit the character for that index number.

Table 2: Key Action When In The Character Edit Mode						
Action	TARE	SELECT	ZERO	PRINT	UNITS	F1
Single Key Press	Increments the flashing digit by 1	Decrements the flashing digit by 1	Enter	Delete flashing digit	Add Digit	ESC/Abort
Long Key Press	Move flashing digit left	Move flashing digit right	Enter	Delete the entire entry	Does nothing	ESC/Abort

10.2 Editing an existing print string

Here is an example of how to edit an existing print string.

1. In the Admin menu, under **Setup>Ports** you will find **P.F.Edit**. With **P.F.Edit** displayed, press **SELECT** ...

PrnFt 1 is displayed. This is Print Format 1.

2. Press **UNITS** or **PRINT** to scroll until the display shows the print format number you want to edit.

In this example let's use format 1 (standard gross, tare and net printout) and add a company name as the header or first line of the printout. Refer to [Default print formats on page 131](#) to view the default settings for print format number 1

3. So from **PRNFT1** press **SELECT** ...

The first character in the print format will be displayed:



Since we want to add a header to the beginning of the printout we will want to insert in front of string index number 1. If you wanted to add characters or tokens in a different area of the printout then you would scroll using the **UNITS** key until the string index number you want to insert in front of is displayed.

For this example let's add the company name **ABC Company**. Start by adding up the number of characters in the company name including any spaces. Then add to this number the carriage return and line feed if necessary. For this example that would be 13 characters. (example of adding up the 13 characters)

A	B	C	Sp	C	o	m	p	a	n	y	Cr	Lf	← Text, etc. to insert
1	2	3	4	5	6	7	8	9	10	11	12	13	← Number of characters to insert
65	66	67	32	67	111	109	112	97	110	121	13	10	← Decimal value to enter

To center the company name on a printed ticket, you must add spaces in front of the company name. This will add to the total count of characters to insert.

10.2.1 Inserting characters

1. To insert characters into a print string, press and hold the **SELECT** key. After you hold the **SELECT** key for about 3 seconds the Index number will start to automatically increment by 1 about every second as Spaces (dec 32) are inserted into the print string. You will still see the current string character on the right side of the display but the string index number will increment as spaces are inserted in front of this character. So for this example, press and hold **SELECT** until the display shown below appears, then release the **SELECT** key ...



2. To start the entry of the company name press the **PRINT** key to scroll backwards until string index number 1 is again displayed, as shown below.



3. Press **SELECT** and the display will show the center bar segments flashing as well as the right digit. This shows you are in the editing mode.



4. Using the numeric keypad enter 65, the decimal value for **A** and press **ZERO**



5. Press **UNITS** to advance to the next string index number and press **SELECT** ...

X, 32 is displayed, where **X** is the next string index number

6. Enter the decimal value for the next letter in the company name and press **ZERO**.

7. Repeat steps 5 and 6 until the last character is entered. In this example that would be **13**, **10** for the line feed.

- Press the **ZERO** to accept the new characters into the print string.



Do not forget step 8 or the changes will not be entered into the print string

- Press **TARE** or **F1** until **SAVE NO** is displayed. Then press **UNITS** and **SAVEYES** is displayed. Press **ZERO** to save.
- After the indicator reboots press the PRINT key to test the results.

10.2.2 Deleting characters

In this example let's use format 1 (Gross, Tare and Net printout) and delete the Tare weight so that only the Gross and Net weight are printed. Refer to [Print tokens, parameters and default print formats on page 119](#) to view the current default settings for print format number 1.

```

Gross      3000 lb
Tare       1000 lb
Net        2000 lb
    
```

1	2	3	4	5	6	7	8	9	10	11	12	13	14	15	16	17	18	19	20
#SP	#SP	#SP	#SP	#SP	G	r	o	s	s	#SP	T.GWT	1	#SP	T.UNIT	1	#CR	#LF	#SP	#SP
32	32	32	32	32	71	114	111	115	115	32	t1	49	32	t9	49	13	10	32	32
21	22	23	24	25	26	27	28	29	30	31	32	33	34	35	36	37	38	39	40
#SP	#SP	#SP	#SP	T	a	r	e	#SP	T.SAT	1	#SP	T.UNIT	1	#CR	#LF	#SP	#SP	#SP	#SP
32	32	32	32	84	97	114	101	32	t2	49	32	t9	49	13	10	32	32	32	32
41	42	43	44	45	46	47	48	49	50	51	52	53	54	55	56	57	58	59	60
#SP	#SP	#SP	N	e	t	#SP	T.NWT	1	#SP	T.UNIT	1	#CR	#LF						
32	32	32	78	101	116	32	t3	49	32	t9	49	13	10	END					

- From **P.F.Edit** press **SELECT ...**

PrnFt1 is displayed.

- Press **SELECT ...**

The first character in the print format will be displayed:



- To move the string index position to the start of the Tare weight output (SP character 32), press the **UNITS** key until the display shows ...



- You need to delete all characters from index position 25 through 36 to remove the entire Tare weight line. Press and hold the **TARE** key for two seconds to delete the displayed character. The remaining characters shift to this index position. Repeatedly press and hold the **TARE** key until the display shows ...



- This is the start of the Net weight output (SP character 32, see current index position 37).
- Press the **ZERO** key when finished with the edit process to accept these changes and return to **PrnFmt1** display.
- Press **TARE** or **F1** until ...
SAVE no is displayed.
- Press **UNITS** ...
SAVEYES is displayed.
- Press **ZERO** to save.

After the indicator reboots press the **PRINT** key to test the results. The following should be printed:

```

~~~~~
Gross  272.04 lb
Net    176.16 lb
~~~~~
  
```



*At any time during a string edit you can press **F1** to abort the print format editor without affecting the existing print string. This allows for an ESCAPE if you think you may have made an error during the editing process.*

10.3 Inserting tokens, etc.

To insert tokens, application variables or optional parameters to add to an existing token there are special characters available to use during character editing. When you are at the string index position where you wish to insert a token or variable, press and hold **SELECT** to insert a space (32). Then press **PRINT** to return to the index position and press **SELECT**. With the **32** displayed, press the **C** key. This will be displayed:

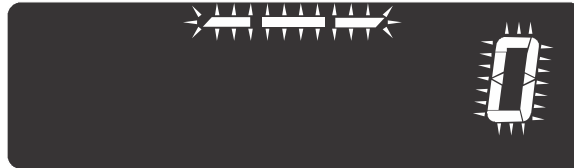

Now press the **SELECT** key to scroll through the following special characters ...

- | | |
|-----------------------------------|--|
|] - (Closing bracket) | End an optional parameter. Added automatically when a Start parameter opening bracket [[is inserted. See the Network tokens on page 127 |
| [- (Opening bracket) | Start an optional parameter. When [[is selected a] is automatically added to the string for your benefit. |
| A - (Application variable) | For Macros the application number is tied to the variable number. In a LUA program you must configure the variable to an application token. |
| t - (Token) | See Firmware tokens on page 120 for available print tokens that can be selected to print. |

When a token **t** (or APP variable **A**) is selected, a decimal 49 is automatically added to indicate printing of the value. If you want to print the name of the token (or APP variable) then change (edit) the 49 to a 50.

Token entry example

If the token for Time is to be inserted, press the **SELECT** key until a **t** is flashing, then enter 200 (decimal value for Time) and press **ZERO**. This will insert the Time into the print string at the selected location. Add appropriate spacing in front or after as needed for proper alignment in the printed data.



The value 1 in the above screen will be whatever index value you started from.

More scale token examples

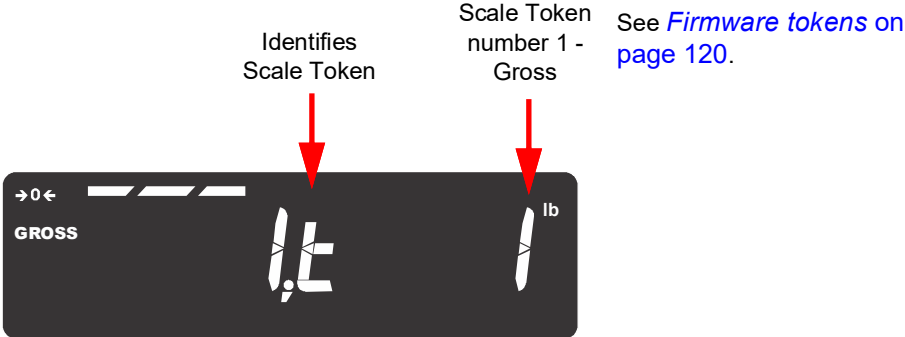

This ASCII number identifies the type of scale token. In this case it identifies the token as the word **Gross**



Above is a typical example of using a scale token. Upon creating the token, **t1** for Gross weight, the indicator automatically appends an additional number in the next character location. The value of the number in this next location identifies what function of the token is being used.

Decimal 1 = 49 is the actual Gross weight value.

Decimal 2 = 50 is the token name, "Gross", applied to that token

10.4 Other scale tokens

In addition to the above, you can examine the tokens available and do much more with the data. For example suppose the Customer's PC can't cope with decimal point in the weight value from the scale. We can add optional parameters after the Gross weight token to remove the decimal point. This print format character sequence would look like this ...



The above token and function will output the text "Gross"



The above token and function will output the Gross weight value.



Characters 5 to 8 will remove the decimal point from the weight transmitted using an attribute parameter. You may need to refer to the [Network tokens on page 127](#) for more detail on necessary character values.

- [= t501** indicates the start of an optional parameter
- 68 = D** for decimal point parameter
- 50 = 2** for hide decimal point
-] = t502** indicates the end of the optional parameter

10.5 Transmitting leading zeroes

A Customer may wish to have the data transmitted with leading zeros and not spaces. The print format sequence would look like this ...



The above token and function will output the text "Gross"



The above token and function will output the Gross weight value.

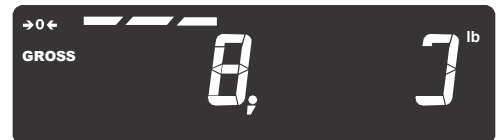

Characters 5 to 8 will add the leading zeros to the weight transmitted using an optional parameter. You may need to refer to [Network tokens on page 127](#) for more detail on necessary character values.

- [= t501 indicates the start of an optional parameter
- 90 = Z for leading zero parameters
- 49 = 1 for use leading zeros
-] = t502 indicates the end of the optional parameter

For more examples of editing formats consult [Print tokens, parameters and default print formats on page 119](#).

10.6 Print format errors

Error	Description
1	Print format number out of range
2	Parser error - no memory
3	A or T token character not found
4	Token Delimiter is missing.
5	Print token invalid range
6	Application variable invalid range
7	Aspect data invalid, codepoint is NOT 1, 2 or 3
8	Invalid UTF8 string
9	Left parameter bracket not found
10	Right parameter bracket not found
11	Dot separator not found
12	Token tag string is invalid
13	UTF8 codepoint too large
14	Token too large
15	Error within optional parameter

11 Print tokens, parameters and default print formats

11.1 Notes on width syntax

11.1.1 Explanation of width syntax for WEIGHT (integers)

Description of Value (T.x.1) represents the system value. The width of the printed value by default is based on configuration items like capacity and division size used. By using syntaxes you can control the number of digits printed, leading zeroes or spaces, left or right justification and much more.

11.1.2 Explanation of width syntax for WEIGHT (strings)

Name Value (T.x.2) represents the string shown. The width of the printed value by default is the entire string shown. By using the (W) width syntax you can control the number of characters used.

For example {GWT.2} prints **Gross** and if you use the width syntax like this {GWT.2[W1]} it would print only **G** because you limited the value to 1 character.

11.1.3 Explanation of width syntax for UNITS OF MEASURE (strings)

Description of Value (T.x.1) represents the system value. The width of the printed value by default is based on configuration items. Units of measure are as shown below without the width syntax all custom units you define are defaulted to a 2-letter width. By using the (W) width syntax you can control the number of digits printed. When offering your own custom unit of measure like TONS you will need to use the WIDTH syntax as follows to have all 3 letters printed to spell TON { T.UNIT.1[W3]}

DEFAULTS:

Pounds	=	lb
Kilograms	=	kg
Grams	=	g
Ounces	=	oz
Pounds/Ounces	=	lb-oz
Custom	=	(first 2 letters)

Token	Token	Description of Value	Name Value	Data Type	Parameter Name	Optional Parameter	Available Values																		
T.x		T.x.1	T.x.2	T.x.3																					
1	GWT	Gross Weight	Gross	WEIGHT	Show sign	P	1 = Show minus (default) 2 = Show plus 3 = Show both 4 = Hide both																		
2	SAT	Semi Automatic Tare Weight	Tare		WEIGHT	Width	W	1 - 127 Characters Default is Configuration Dependent																	
3	NWT	Net Weight	Net			WEIGHT	Precision	P	0 - 127 Characters Default is Configuration Dependent																
10	PGW	Peak Gross Weight	Peak Max				WEIGHT	Leading Zero	Z	0 = None (default) 1 = Leading Zeros 2 = Leading Spaces 3 = Show All 4 = Hide All															
11	PNW	Peak Net Weight	Peak Min					WEIGHT	Multiplier	m	0 = None or *1 (default) 1 = Multiply *10 2 = Multiply *100 3 = Multiply *1000														
13	PCE	Piece Weight	Piece Weight						WEIGHT	Decimal Point	D	1 = Show decimal (default) 2 = Hide Decimal													
14	HAO	Hub Analog Output	HubAnalogOut							WEIGHT	Justification	J	1 = Right (default) 2 = Left												
16	ACT	Active Displayed Value	Spelled Active Value								WEIGHT	Unit of Measure	u (Never use 'u' and 'r' together in the same weight syntax) (This syntax should only be used with high resolution weight tokens)	1 = Current displayed Unit of measure (default) 2 = Calibration Unit 3 = Rounded Current Unit 4 = Rounded Calibration Unit 5 = lb 6 = kg 7 = oz 8 = g 9 = lb-oz 10 = Custom Unit 1 11 = Custom Unit 2 12 = Custom Unit 3 13 = Custom Unit 4											
18	ROC	Rate of Change										WEIGHT	Scale	S	0 = Current Scale 1 = Scale 1 2 = Scale 2										
19	PMAX	Peak Maximum Weight	Peak Max										WEIGHT												
20	PMIN	Peak Minimum Weight	Peak Min											WEIGHT											
35	GWTHR	High Resolution Gross Weight	GrossHiRes												WEIGHT										
36	NWTHR	High Resolution Net Weight	NetHiRes													WEIGHT									
37	INMOWT	Active Displayed In-Motion Weight Value	In-Motion Weight														WEIGHT								
39	INMOGWT	AVERAGED In-Motion Gross Weight Value	Gross Avg															WEIGHT							
40	INMONWT	AVERAGED In-Motion Net Weight Value	Net Avg																WEIGHT						
41	ACTM	Active Weight Value with Motion GR=Gross no-motion gr=Gross with motion NT=Net no motion nt=New with motion	GR gr NT nt																	WEIGHT					
42	LSTSTBL	Last Stable Weight	Last Stable Weight																		WEIGHT				
47	PER	Percent	Percent																			WEIGHT			
48	TGT	Target Weight	Target																				WEIGHT		
49	GWTPC	Gross Total + Current Gross Weight	Gross Total + Current	WEIGHT																					

Token	Token	Description of Value	Name Value	Data Type	Parameter Name	Optional Parameter	Available Values
T.x		T.x.1	T.x.2	T.x.3			
50	GWTMC	Gross Total - Current Gross Weight	Gross Total - Current	WEIGHT (cont.)	Binary Output	B	1 = Truncate to 1-Byte Integer 2 = Truncate to 2-Byte Integer 3 = Truncate to 4-Byte Integer 4 = 4-Byte Floating Point
51	NWTPC	Net Total + Current Net Weight	Net Total + Current		Rounded Unit of Measure	r (Never use 'u' and 'r' together in the same weight syntax) (This syntax should only be used with high resolution weight tokens)	
52	NWTMC	Net Total - Current Net Weight	Net Total - Current		Binary Conversion	c	1 = As Binary (High Byte First) 2 = As Comma Separated Decimal in ASCII Format (High Byte First) 3 = As HEX in ASCII Format (High Byte First)
53	CNTPC	Count Total + Current Count Weight	Count Total + Current		Polarity Character	v	Just a "+" or "-" character.
54	CNTMC	Count Total - Current Count Weight	Count Total - Current				
55	GAVG	Gross Average Weight	Gross Average				
56	NAVG	Net Average Weight	Net Average				
57	CAVG	Count Average Weight	Count Average				
58	NMAX	Net Maximum Weight	Net Maximum				
59	NMIN	Net Minimum Weight	Net Minimum				
60	FF1	Free Fall Time 1	Free Fall Time 1				
61	FF2	Free Fall Time 2	Free Fall Time 2				
62	FGWT1	Future Gross Weight 1	Future Gross 1				
63	FGWT2	Future Gross Weight 2	Future Gross 2				
64	FNWT1	Future Net Weight 1	Future Net 1				
65	FNWT2	Future Net Weight 2	Future Net 2				
66	PCEK	Piece Weight x 1000	Piece Weight x 1000				
67	ACC	Percent Accuracy	Percent Accuracy				
68	SAMP	Last Sample Weight	Last Sample				
100	GWTAS	Gross Weight of All Scales	Gross All Scales				
101	TATAS	Tare Weight of All Scales	Tare All Scales				
102	NWTAS	Net Weight of All Scales	Net All Scales				
103	CNTAS	Count of All Scales	Count All Scales				
104	GAT	Accumulated Gross Weight Total	Gross Total				
105	TAT	Accumulated Tare Weight Total	Tare Total				
106	NAT	Accumulated Net Weight Total	Net Total				
108	GATAS	Gross Total All Scales Totals	Gross Total All Scales				
109	NATAS	Net Total All Scales Totals	Net Total All Scales				
110	TATAS	Tare Total All Scales Totals	Tare Total All Scales				
111	CATAS	Count Total All Scales Totals	Count Total All Scales				

Token	Token	Description of Value	Name Value	Data Type	Parameter Name	Optional Parameter	Available Values
T.x		T.x.1	T.x.2	T.x.3			
200	TIM	Time	Time	TIME	Time Format	F	0 = As Configured (default) 1 = HH:MM:SS (12hr) 2 = HH:MM AM/PM 3 = HH:MM:SS (24hr)
					Seconds Format	S	0 = As Configured (default) 1 = Hide Seconds 2 = Seconds Since Midnight 3 = Both 1 and 2 4 = Number of seconds since Jan. 1, 1970. (unixtime)
					Width	W	1 - 127 Characters Default is Configuration Dependent
					Time Separator	s	1 = None 2 = Comma (,) 3 = Period or Decimal Point (.) 4 = Backslash (\) 5 = Space () 6 = Forward Slash (/) 7 = Colon (:) 8 = Dash (-)
201	DAT	Date	Date	DATE	Format	F	0 = As Configured (default) 1 = MM-DD-YY 2 = MM-DD-YYYY 3 = DD-MM-YY 4 = DD-MM-YYYY 5 = YY-MM-DD 6 = YYYY-MM-DD 7 = DD-YY-MM 8 = DD-YYYY-MM 9 = YY-DD-MM 10 = YYYY-DD-MM 11 = WW-YY 12 = WW-YYYY 13 = YY-WW 14 = YYYY-WW
					Show Day of Week	d	d = day of the week spelled out (MON, TUES, etc.)
					Day of the year	j	j = number of days since beginning of the year
					Spelled Date	S	S = month spelled out (MAY, JUNE, etc.)
					Width	W	1 - 127 Characters Default is Configuration Dependent
Separator	s	1 = None 2 = Comma (,) 3 = Period or Decimal Point (.) 4 = Backslash (\) 5 = Space () 6 = Forward Slash (/) 7 = Colon (:) 8 = Dash (-) (default)					

Token	Token	Description of Value	Name Value	Data Type	Parameter Name	Optional Parameter	Available Values
T.x		T.x.1	T.x.2	T.x.3			
4	MOTN	Motion	Motion	INTEGER	Show Sign	p	1 = Show - (default) 2 = Show + 3 = Show All 4 = Hide All
6	OVER	Overload	Overload		Leading Zero	Z	0 = None (default) 1 = Leading Zeros 2 = Leading Spaces
7	UNDER	Underload	Underload		Width	W	1 - 127 Characters Default is Configuration Dependent
8	CZ	Center of Zero	Center of Zero		Justification	J	1 = Right (default) .2 = Left
12	CNT	Count	Count				
38	INMOTM	InMotion Time	InMotion Time				
107	CAT	Accumulated Count Value Total	Count Total				
250	OUT1	Output 1 State: 0 = Not Active, 1 = Active	OUT1				
251	OUT2	Output 2 State: 0 = Not Active, 1 = Active	OUT2				
252	OUT3	Output 3 State: 0 = Not Active, 1 = Active	OUT3				
300	RTN	Transaction Count	Transaction Count				
301	CON	Consecutive Number	Consecutive Number				
304	B2H	Binary to Hexadecimal	Bin2Hex				
305	B2A	Binary to ASCII	Bin2Asc				
313	DIS	Status Byte See Additional token tables on page 126	Status		Mode (Applies to tokens 304 and 305 only)	M	1 = Stop (default) 2 = Start
					Binary Output	B	1 = Truncate to 1-Byte Integer 2 = Truncate to 2-Byte Integer 3 = Truncate to 4-Byte Integer 4 = 4-Byte Floating Point
314	UTID	Unique ID (Archive menu)	DSD Consec.		Binary Conversion	c	1 = As Binary (High Byte First) 2 = As Comma Separated Decimal in ASCII Format (High Byte First) 3 = As HEX in ASCII Format (High Byte First)
302	CKSM	Checksum	Checksum	Mode Applies to token 302 only	M	1 = Stop 2 = Transmit LSB First 3 = Transmit MSB First 4 = Send CRC 7-Bit 50 = Start CCITT 51 = Start SDLC / HDLC 52 = Start CRC 16 (0000) 53 = Start CRC 12 54 = Start IRCC 16 55 = Start IRCC 8 56 = Start Xmodem 57 = Start Sum 16 58 = Start Sum 8 59 = Start CRC 16 (FFFF) 60 = Start Inverse IRCC 8 61 = Start Sum 16 (W/O Twos) 62 = BCC	

Token	Token	Description of Value	Name Value	Data Type	Parameter Name	Optional Parameter	Available Values
T.x		T.x.1	T.x.2	T.x.3			
9	UNIT	Unit of Measure Type	Unit	STRING	Unit of Measure <i>Applies to token 9 only</i>	U	1 = Current (default) 2 = Calibration 3 = lb 4 = kg 5 = oz 6 = g 7 = lb-oz 8 = Custom Unit 1 9 = Custom Unit 2 10 = Custom Unit 3 11 = Custom Unit 4
5	WST	Motion = M Stable or no motion = S	sMotion				
15	WSTAT	Weight Status See Additional token tables on page 126	Weight Status				
17	TSAT	Returns type of Tare used See Additional token tables on page 126	Tare Type				
28	HEX	Prints HEX value of a ASCII Decimal Value	Hexadecimal		<i>Applies to token 28 only.</i>	non-optional parameter <i>[hXX]</i>	0 through 255
29	NCIBYTE1	Returns NCI Status Byte 1 only See Additional token tables on page 126	NCI Status Byte 1				
30	NCIBYTE2	Returns NCI Status Byte 2 only See Additional token tables on page 126	NCI Status Byte 2				
31	NCIBYTE3	Returns NCI Status Byte 3 only See Additional token tables on page 126	NCI Status Byte 3				
32	NCIBYTE12	Returns NCI Status Bytes 1 & 2 only See Additional token tables on page 126	NCI Status Bytes 12				
33	NCIBYTE23	Returns NCI Status Bytes 2 & 3 only See Additional token tables on page 126	NCI Status Bytes 23				
34	NCIBYTE123	Returns NCI Status Bytes 1, 2 & 3 See Additional token tables on page 126	NCI Status Bytes 123				
309	SITE	Site ID	Site ID				
310	SN	Serial Number	Serial Number		Justification	J	1 = Right (default) 2 = Left
311	LK	Condec Units = L or K	Condec Units				
312	STAT	Condec Status = " " (space = stable) "M" = motion "O" = out of range	Condec Status		Width	W	1 - 127 Characters
323	S127	WI-127 Status Byte	127 Status				STATUS CODES These are the most common characters you will see on a terminal: "0" = Valid weight "1" = Motion "2" = Range error (Over/Underload) "4" = A-D error "8" = Low voltage Combinations of these errors can also occur. (e.g., "3" = Range error (2) plus Motion (1))
324	NAME	Indicator Scale Name	Scale Name				
325	LOC	Indicator Scale Location	Scale Location				32 characters max entered in Ztools under SYSTEM TAB

Token	Token	Description of Value	Name Value	Data Type	Parameter Name	Optional Parameter	Available Values
T.x		T.x.1	T.x.2	T.x.3			
21	SMOTSTR	Sets values for Motion TRUE / FALSE	sSPCMot	STRING (cont.)	Applies to tokens 21-27 only		Using these tokens requires use of the required parameter [tXXfYY] where XX and YY represent the ASCII hex character (1-255) to be sent for a true or false condition respectively. The XX or YY must be entered as individual decimal values. Example: To send a "1" for true or "0" for false condition the parameter would be entered as [116 52 57 102 52 56] in the Print Format Editor.
22	SCZSTR	Sets values for Center of Zero TRUE / FALSE	sSPCCZ				
23	SOLDSTR	Sets values for Overload TRUE / FALSE	sSPCOld				
24	SULDSTR	Sets values for Underload TRUE / FALSE	sSPCUld				
25	SGPOL	Sets values for Gross Polarity	sSPCGPol				
26	SNPOL	Sets values for Net Polarity	sSPCNPol				
27	SAPOL	Sets values for Active Value Polarity	sSPCAPol				
500	NULL	Null	NULL	Undefined			
501	SOP	Start Optional Parameters	SOP		[
502	EOP	End Optional Parameters	EOP]		
600	TEXT	Print Data is Text	Data Type Text		"<ESC>txt"		
601	PCL	Print Data is Printer Control Language	Data Type PCL		"<ESC>PCL"		
602	EPPOS	Print Data is Epson Point of Sale	Data Type Epson Pos		"<ESC>EPS"		
603	ZEBRA	Print Data is Zebra Language	Data Type Zebra		"<ESC>ZEB"		
604	RAW	Print Data is RAW	Data Type RAW		"<ESC>raw"		
650	BOLD	Print Format Bold	Format Bold		"<ESC><ESC>B"		
651	ITAL	Print Format Italic	Format Italic		"<ESC><ESC>I"		
652	UNDR	Print Format Underline	Format Underline		"<ESC><ESC>U"		
653	LAND	Print Format Landscape	Format Landscape		"<ESC><ESC>L"		
654	FF	Print Format Form feed	Format Form Feed		"<ESC><ESC>F"		
655	WRAP	Print Format Line Wrap	Format Line Wrap		"<ESC><ESC>W"		

11.2.1 Additional token tables

WSTAT token table	
"O"	Overload
"U"	Underload
"M"	Motion
"S"	Stable
"E"	Cal error

TSAT token table	
"NT"	no tare active
"T"	pushbutton tare active
"PT"	preset or enter tare active

The WSTAT and TSAT token default length is 6 characters.

DIS token table: AWTX Status Byte format			
	Byte 1	Byte 2	Byte 3
Bit 0	1 = Under or OverLoad	1 = Center Zero	0
Bit 1	0	1=Gross	1
Bit 2	1=kg	1=Net	1=Overload
Bit 3	1=lb	0	1=Motion
Bit 4	1	1	1
Bit 5	1	1	1
Bit 6	0	0	0
Bit 7	0	0	0

Example: Stable and valid gross weight in lb unit of measure would return "822"

NCI Status Byte Table

Bit	Byte 1	Byte 2	Byte 3
1	1 = Scale in motion 0 = Stable	1=Underloaded 0 = Not Underloaded	00 = Low Range 01 = Undefined 10 = Undefined 11 = High Range
2	1 = Scale at Zero 0 =Not at Zero	1= Overloaded 0 = Not Overloaded	
3	1 = RAM error 0 = RAM OK	1 = ROM error 0 = ROM OK	1 = Net Weight 0 = Gross Weight
4	Always 0	1 = Faulty Calibration 0 = Calibration OK	1 = Initial Zero Error 0 = Initial Zero OK
5	Always 1	Always 1	Always 1
6	Always 1	Always 1	Always 1
7	Always 0	1 = Byte follows 0 = Last Byte	1 = Byte follows 0 = Last Byte
8	Parity	Parity	Parity

11.3 Network tokens

Token	SMA protocol		PLC Protocol		Description of Network Token	Data Type			ZM305 Standard Applications							ZM305 GTN App.	Notes	
	Set XVS	Get XVG	Inbound	Outbound		INTEGER	FLOAT	STRING	General	Accumulate	Counting	Checkweighing	Batching	Peak Hold	Remote Display	In-Motion		In/Out
0					Disabled				X	X	X	X	X	X	X	X	X	
1		X		X	Gross Weight Value		X		X	X	X	X	X	X	X	X	X	
2	X	X	X	X	Tare Weight Value		X		X	X	X	X	X	X	X	X	X	
3		X		X	Net Weight Value		X		X	X	X	X	X	X	X	X	X	
4		X		X	Scale Motion / Weigher Steady Flag	X			X	X	X	X	X	X	X	X	X	0 = Motion on Scale / Unsteady Weight 1 = No Motion on Scale / Steady Weight
6		X		X	Scale Overload Flag	X			X	X	X	X	X	X	X	X	X	0 = Scale is NOT Overloaded 1 = Scale is Overloaded
7		X		X	Scale Underload Flag	X			X	X	X	X	X	X	X	X	X	0 = Scale is NOT Underloaded 1 = Scale is Underloaded
8		X		X	Scale Center of Zero / Zero Balance	X			X	X	X	X	X	X	X	X	X	0 = Scale is NOT at Center of Zero / Zero Balanced 1 = Scale is at Center of Zero / Zero Balanced
9	X	X	X	X	Active Unit of Measure	X			X	X	X	X	X	X	X	X	X	0 = lb 1 = kg 2 = oz 3 = g 4 = lb-oz 5 = Custom Unit #1 6 = Custom Unit #2 7 = Custom Unit #3 8 = Custom Unit #4
10		X		X	Peak Max Weight Value		X							X				
11		X		X	Peak Min Weight Value		X							X				
12		X		X	Count Value	X				X								
13	X	X	X	X	Piece Weight Value		X			X								
104	X	X	X	X	Accumulated Gross Weight Total Value		X			X	X							
105		X		X	Accumulated Tare Weight Total Value		X			X	X							
106	X	X	X	X	Accumulated Net Weight Total Value		X			X	X							
107	X	X	X	X	Accumulated Count Total Value	X				X								
257		X		X	Indicator Watchdog Counter Value	X			X	X	X	X	X	X	X	X	X	Enables Operator to verify scale is functioning
300	X	X	X	X	Transaction Counter Value	X				X	X							
310		X		X	Indicator Serial Number	X			X	X	X	X	X	X	X	X	X	
313		X		X	Indicator Healthy Status (2-Byte)	X			X	X	X	X	X	X	X	X	X	Output of 2-bytes which indicate any faults. With no Errors = 0xFFFF BYTE #1: Bit 0 = Any Fault Bit 1 = ADC Error Bit 2, 3, 4 = N/A Bit 5 = Overload Condition Bit 6 = Underload Condition Bit 7 = N/A

Token	SMA protocol		PLC Protocol		Description of Network Token	Data Type			ZM305 Standard Applications								ZM305 GTN App.	Notes	
	Set XVS	Get XVG	Inbound	Outbound		INTEGER	FLOAT	STRING	General	Accumulate	Counting	Checkweighing	Batching	Peak Hold	Remote Display	In-Motion	In/Out		
700	X	X	X	X	Indicator Input Status Byte	X			X	X	X	X	X	X	X	X	X	X	Bit 0 = Input #1, #2 and #3 is OFF Bit 1 = Input #1 is ON Bit 2 = Input #2 is ON Bit 3 = Input #1 and #2 is ON Bit 4 = Input #3 is ON Bit 5 = Input #1 and #3 is ON Bit 6 = Input #2 and #3 is ON Bit 7 = Input #1, #2 and #3 is ON
800	X	X	X	X	Indicator Output Status Byte	X			X	X	X	X	X	X	X	X	X	X	Bit 0 = Output #1, #2 and #3 is OFF Bit 1 = Output #1 is ON Bit 2 = Output #2 is ON Bit 3 = Output #1 and #2 is ON Bit 4 = Output #3 is ON Bit 5 = Output #1 and #3 is ON Bit 6 = Output #2 and #3 is ON Bit 7 = Output #1, #2 and #3 is ON
900	X		X		Remote PB Zero Key	X			X	X	X	X	X	X	X	X	X	X	These value are configuration dependent. The following commands will change their value or function if the register which is mapped from the host changes at any time. XOR the mapped register with a "1" to toggle the register every time the XOR is executed.
901	X		X		Remote PB Tare Key	X			X	X	X	X	X	X	X	X	X	X	
902	X		X		Remote PB Print Key	X			X	X	X	X	X	X	X	X	X	X	
903	X		X		Remote PB Accumulate Key	X				X	X								
904	X		X		Remote PB Units Key	X			X	X	X	X	X	X	X	X	X	X	

* the "Low Weight Value" and "High Weight Value" only apply when the Output mode selection is Act-In or Act-Out

11.4 ASCII characters

Code #	Cont. Char.	Print Char.	Hex	Code #	Cont. Char.	Print Char.	Hex	Code #	Cont. Char.	Print Char.	Hex	Code #	Cont. Char.	Print Char.	Hex	Code #	Cont. Char.	Print Char.	Hex			
0	NUL		00	045	-	-	2D	090	Z	Z	5A	0128	NA	€	80	0173	NA	ad	0218	NA	ú	da
01	SOH	☺	01	046	.	.	2E	091	[[5B	0129	NA		81	0174	NA	ae	0219	NA	û	db
02	STX	☹	02	047	/	/	2F	092	\	\	5C	0130	NA	,	82	0175	NA	af	0220	NA	ü	dc
03	ETX	♥	03	048	0	0	30	093]]	5D	0131	NA	f	83	0176	NA	b0	0221	NA	ý	dd
04	EOT	♦	04	049	1	1	31	094	^	^	5E	0132	NA	„	84	0177	NA	b1	0222	NA	þ	de
05	ENG	♣	05	050	2	2	32	095	_	_	5F	0133	NA	…	85	0178	NA	b2	0223	NA	ß	df
06	ACK	♠	06	051	3	3	33	096	`	`	60	0134	NA	†	86	0179	NA	b3	0224	NA	à	e0
07	BEL		07	052	4	4	34	097	a	a	61	0135	NA	‡	87	0180	NA	b4	0225	NA	á	e1
08	BS		08	053	5	5	35	098	b	b	62	0136	NA	ˆ	88	0181	NA	b5	0226	NA	â	e2
09	HT		09	054	6	6	36	099	c	c	63	0137	NA	‰	89	0182	NA	b6	0227	NA	ã	e3
010	LF	LF	0A	055	7	7	37	0100	d	d	64	0138	NA	‰	8a	0183	NA	b7	0228	NA	ä	e4
011	VT	⊙	0B	056	8	8	38	0101	e	e	65	0139	NA	<	8b	0184	NA	b8	0229	NA	å	e5
012	FF	FF	0C	057	9	9	39	0102	f	f	66	0140	NA	€	8c	0185	NA	b9	0230	NA	æ	e6
013	CR	CR	0D	058	:	:	3A	0103	g	g	67	0141	NA	□	8d	0186	NA	ba	0231	NA	ç	e7
014	S0	🎵	0E	059	;	;	3B	0104	h	h	68	0142	NA	ž	8e	0187	NA	bb	0232	NA	è	e8
015	S1	⚙	0F	060	<	<	3C	0105	i	i	69	0143	NA		8f	0188	NA	bc	0233	NA	é	e9
016	DLE	4	10	061	=	=	3D	0106	j	j	6A	0144	NA		90	0189	NA	bd	0234	NA	ê	ea
017	DC1	3	11	062	>	>	3E	0107	k	k	6B	0145	NA	‚	91	0190	NA	be	0235	NA	ë	eb
018	DC2	ø	12	063	?	?	3F	0108	l	l	6C	0146	NA	‚	92	0191	NA	bf	0236	NA	ì	ec
019	DC3	∅	13	064	@	@	40	0109	m	m	6D	0147	NA	“	93	0192	NA	c0	0237	NA	í	ed
020	DC4	β	14	065	A	A	41	0110	n	n	6E	0148	NA	”	94	0193	NA	c1	0238	NA	î	ee
021	NAK	§	15	066	B	B	42	0111	o	o	6F	0149	NA	•	95	0194	NA	c2	0239	NA	ï	ef
022	SYN		16	067	C	C	43	0112	p	p	70	0150	NA	–	96	0195	NA	c3	0240	NA	ò	f0
023	ETB	—	17	068	D	D	44	0113	q	q	71	0151	NA	—	97	0196	NA	c4	0241	NA	ñ	f1
024	CAN	↑	18	069	E	E	45	0114	r	r	72	0152	NA	˘	98	0197	NA	c5	0242	NA	ó	f2
025	EM	↓	19	070	F	F	46	0115	s	s	73	0153	NA	‰	99	0198	NA	c6	0243	NA	ô	f3
026	SUB	→	1A	071	G	G	47	0116	t	t	74	0154	NA	‰	9a	0199	NA	c7	0244	NA	õ	f4
027	ESC	←	1B	072	H	H	48	0117	u	u	75	0155	NA	>	9b	0200	NA	c8	0245	NA	ö	f5
028	FS	—	1C	073	I	I	49	0118	v	v	76	0156	NA	œ	9c	0201	NA	c9	0246	NA	ø	f6
029	GS	—	1D	074	J	J	4A	0119	w	w	77	0157	NA	ℓ	9d	0202	NA	ca	0247	NA	÷	f7
030	RS	5	1E	075	K	K	4B	0120	x	x	78	0158	NA	ž	9e	0203	NA	cb	0248	NA	∅	f8
031	US	6	1F	076	L	L	4C	0121	y	y	79	0159	NA	ÿ	9f	0204	NA	cc	0249	NA	ù	f9
032	SP		20	077	M	M	4D	0122	z	z	7A	0160	NA	€	a0	0205	NA	cd	0250	NA	ú	fa
033	!	!	21	078	N	N	4E	0123	{	{	7B	0161	NA	;	a1	0206	NA	ce	0251	NA	û	fb
034	"	"	22	079	O	O	4F	0124			7C	0162	NA	ç	a2	0207	NA	cf	0252	NA	ü	fc
035	#	#	23	080	P	P	50	0125	}	}	7D	0163	NA	€	a3	0208	NA	d0	0253	NA	ý	fd
036	\$	\$	24	081	Q	Q	51	0126	~	~	7E	0164	NA	¤	a4	0209	NA	d1	0254	NA	þ	fe
037	%	%	25	082	R	R	52	0127	DEL	␣	7F	0165	NA	¥	a5	0210	NA	d2	0255	NA	ÿ	ff
038	&	&	26	083	S	S	53					0166	NA	!	a6	0211	NA	d3				
039	'	'	27	084	T	T	54					0167	NA	§	a7	0212	NA	d4				
040	((28	085	U	U	55					0168	NA	¨	a8	0213	NA	d5				
041))	29	086	V	V	56					0169	NA	©	a9	0214	NA	d6				
042	*	*	2A	087	W	W	57					0170	NA	ª	aa	0215	NA	d7				
043	+	+	2B	088	X	X	58					0171	NA	«	ab	0216	NA	d8				
044	,	,	2C	089	Y	Y	59					0172	NA	¬	ac	0217	NA	d9				

11.5 Control codes

ASCII	Control Code Description	Control
1	Start of Heading	#SOH
2	Start of Text	#STX
3	End of Text	#ETX
4	End of Transmission	#EOT
5	Enquiry	#ENQ
6	Acknowledge	#ACK
7	Bell	#BEL
8	Backspace	#BS
9	Horizontal Tab	#TAB
10	Line Feed (New Line)	#LF
11	Vertical Tab	#VT
12	Form Feed (New Page)	#FF
13	Carriage Return	#CR
14	Shift Out	#SO
15	Shift In	#SI
16	Data Link Escape	#DLE
17	Device Control 1	#DC1
18	Device Control 2	#DC2
19	Device Control 3	#DC3
20	Device Control 4	#DC4
21	Negative Acknowledge	#NAK
22	Synchronous Idle	#SYN
23	End of Block	#ETB
24	Cancel	#CAN
25	End of Medium	#EM
26	Substitute	#SUB
27	Escape	#ESC
28	File Separator	#FS
29	Group Separator	#GS
30	Record Separator	#RS
31	Unit Separator	#US

11.6 Default print formats

Num	Description	Tokenized Format	Example	Print Format Editor Position																			
				1	2	3	4	5	6	7	8	9	10	11	12	13	14	15	16	17	18	19	20
1	Gross Tare Net	Gross {T.GWT.1}{T.UNIT.1}#CR#LF Tare {T.SAT.1}{T.UNIT.1}#CR#LF Net {T.NWT.1}{T.UNIT.1}#CR#LF	<pre style="border: 1px dashed black; padding: 5px;"> Gross 3000 lb Tare 1000 lb Net 2000 lb </pre>	#SP	#SP	#SP	#SP	#SP	G	r	o	s	s	#SP	T.GWT	1	#SP	T.UNIT	1	#CR	#LF	#SP	#SP
				32	32	32	32	32	71	114	111	115	115	32	t1	49	32	t9	49	13	10	32	32
				21	22	23	24	25	26	27	28	29	30	31	32	33	34	35	36	37	38	39	40
				#SP	#SP	#SP	#SP	T	a	r	e	#SP	T.SAT	1	#SP	T.UNIT	1	#CR	#LF	#SP	#SP	#SP	#SP
				32	32	32	32	84	97	114	101	32	t2	49	32	t9	49	13	10	32	32	32	32
				41	42	43	44	45	46	47	48	49	50	51	52	53	54	55	56	57	58	59	60
				#SP	#SP	#SP	N	e	t	#SP	T.NWT	1	#SP	T.UNIT	1	#CR	#LF						
32	32	32	78	101	116	32	t3	49	32	t9	49	13	10	END									
5	Active value and Displayed Weight	{T.ACT.2[W1]}{T.ACT.1}{T.UNIT.1}#CR#LF	<pre style="border: 1px dashed black; padding: 5px;"> G 2000 lb </pre>	1	2	3	4	5	6	7	8	9	10	11	12	13	14	15	16	17	18	19	20
				T.ACT	2	[W	1]	#SP	T.ACT	1	#SP	T.UNIT	1	#CR	#LF						
				t16	50	t501	87	49	t502	32	t16	49	32	t9	49	13	10	END					
7	Displayed Weight and Active value	{T.ACT.2[W1]}{T.ACT.1}{T.UNIT.1}#CR#LF	<pre style="border: 1px dashed black; padding: 5px;"> 1000 lb G </pre>	1	2	3	4	5	6	7	8	9	10	11	12	13	14	15	16	17	18	19	20
				T.ACT	1	#SP	T.UNIT	1	#SP	T.ACT	2	[W	1]	#CR	#LF						
				t16	49	32	t9	49	32	t16	50	t501	87	49	t502	13	10	END					
32	High Resolution Gross weight (typically used for Analog option)	{T.GWTHR.1[r2W8]}	<pre style="border: 1px dashed black; padding: 5px;"> 120032 </pre>	1	2	3	4	5	6	7	8	9	10	11	12	13	14	15	16	17	18	19	20
				T.GWTHR	1	[r	2	W	8]												
				t35	49	t501	114	50	87	56	t502	END											



12 Complete menu structures

ADMIN Level Menu



Menu Navigation Keys:

Press **SELECT/ ▼** to move down in a menu
 Press **TARE/ ▲** to move up in a menu, except at the bottom item in a menu, then use **ZERO/ ←** or **F1**
 Press **PRINT/ ◀** to move left in a menu
 Press **UNITS/ ▶** to move right in a menu
 Press **ZERO/ ←** to accept a value or choice and move up in the menu.
 Press **F1** to escape and move up in the menu

Setup Top Level Menu

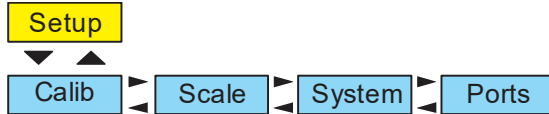

User Menu

See [User menu on page 24](#)

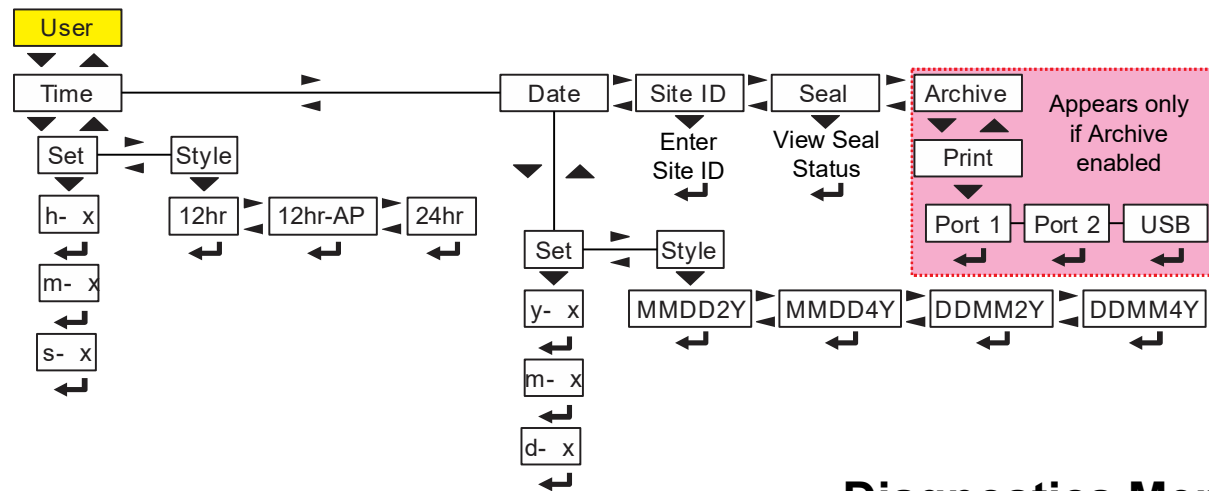

Audit Menu

See [Audit menu on page 31](#)

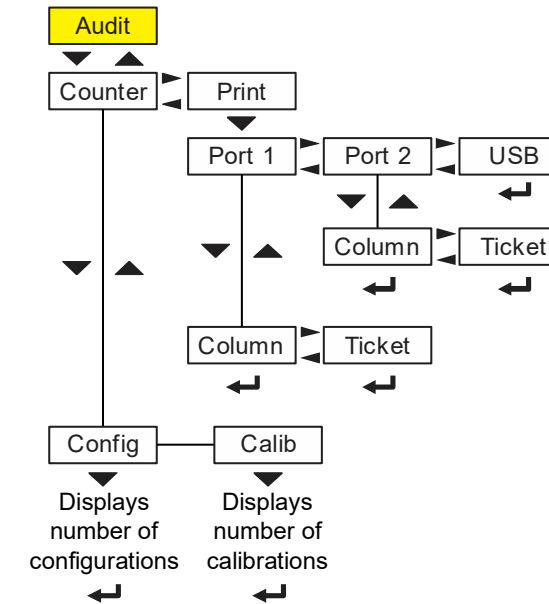

Diagnostics Menu

See [Diag menu on page 33](#)

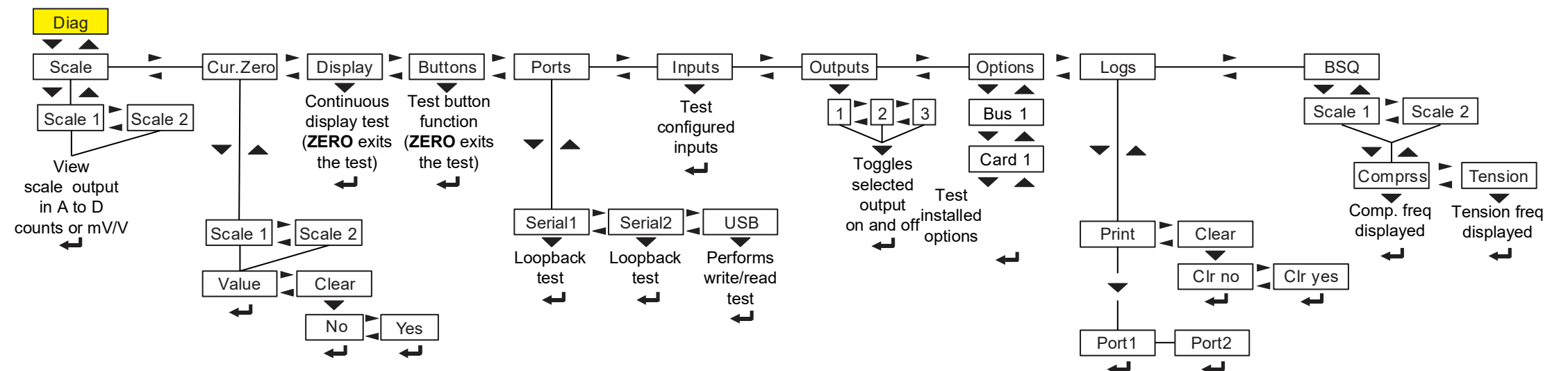

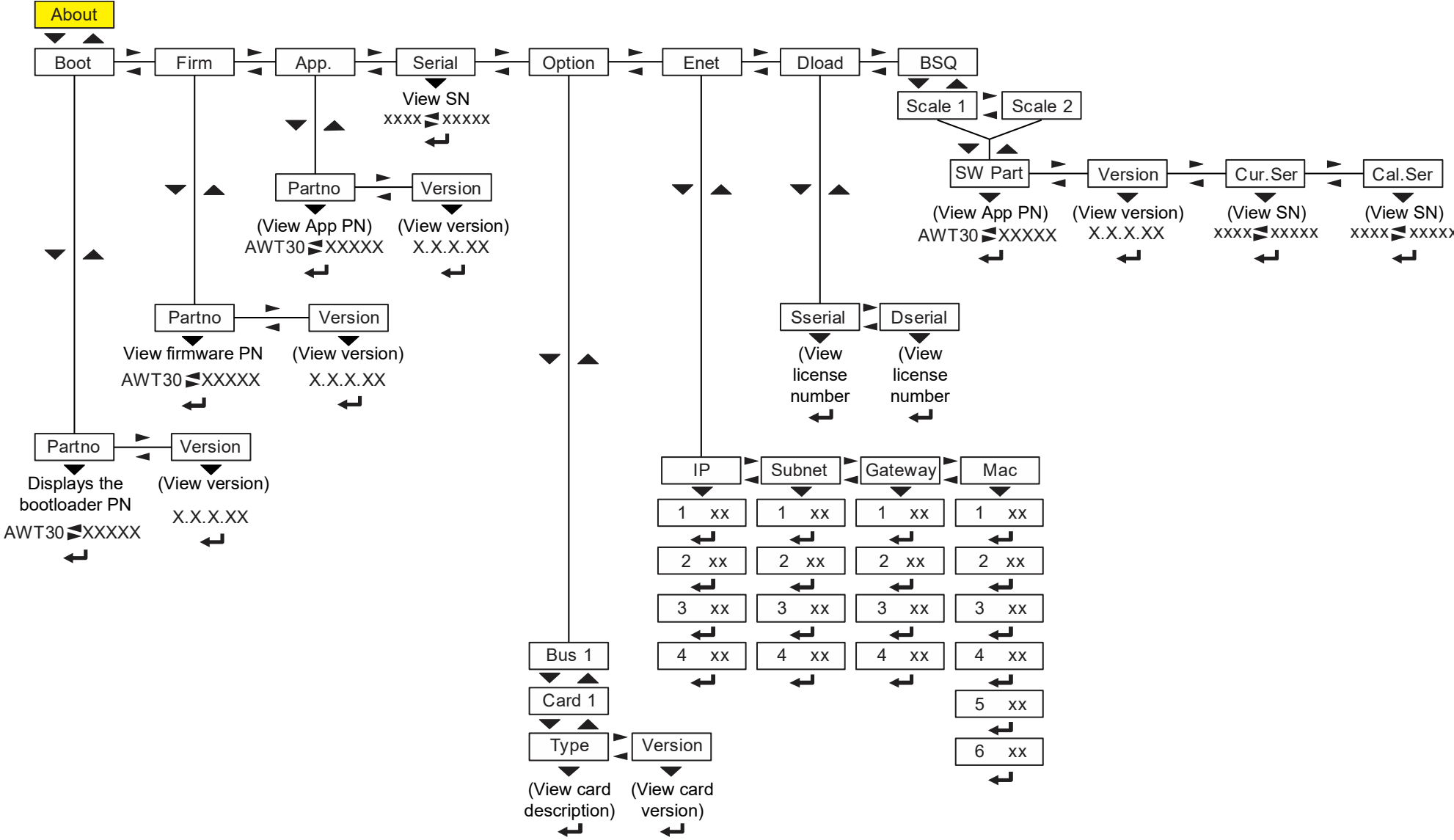

Calibration Menu

See [Calibration Procedure on page 40](#)

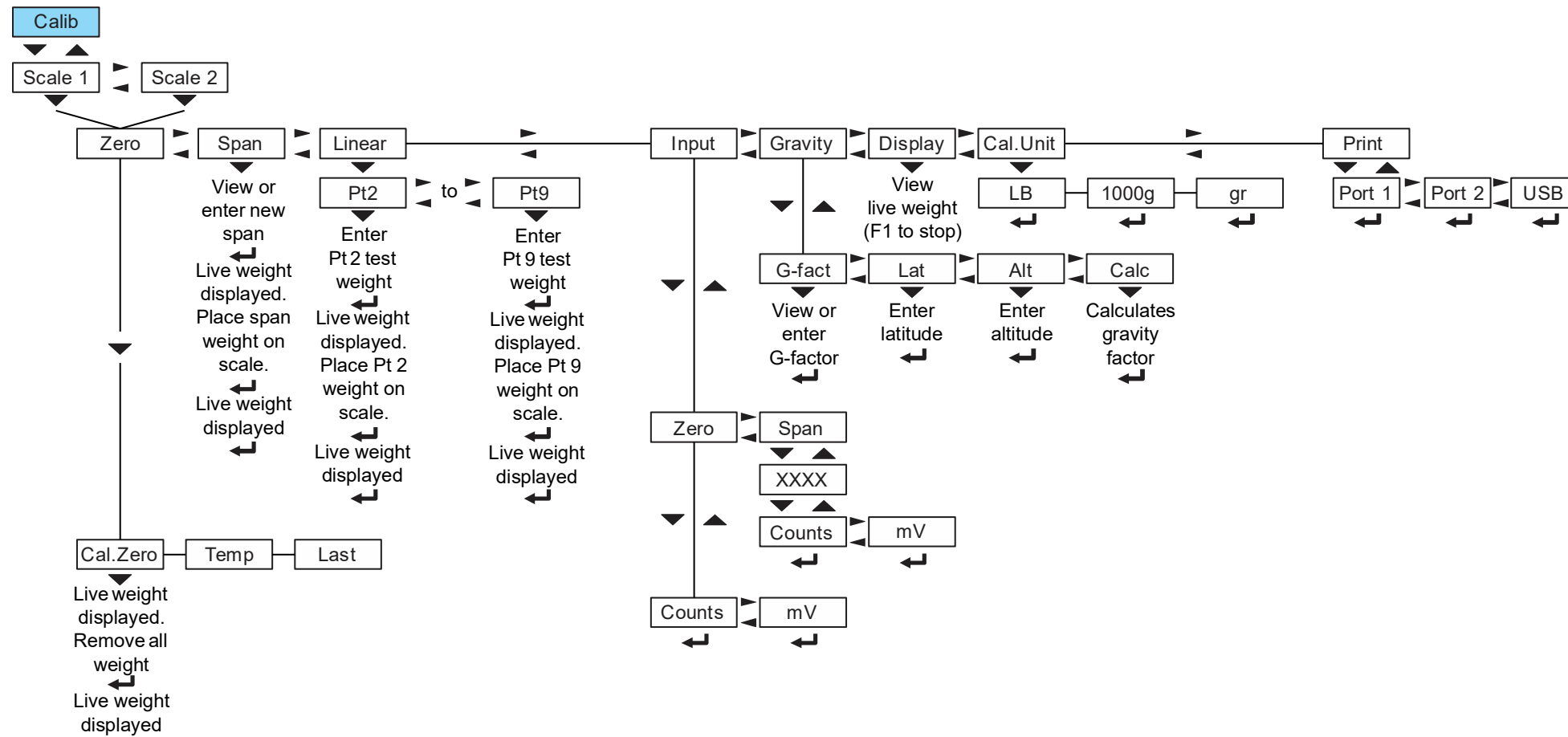

Menu Navigation Keys:

- Press **SELECT**/ ▼ to move down in a menu
- Press **TARE**/ ▲ to move up in a menu, except at the bottom item in a menu, then use **ZERO**/ ← or **F1**
- Press **PRINT**/ ◀ to move left in a menu
- Press **UNITS**/ ▶ to move right in a menu
- Press **ZERO**/ ← to accept a value or choice and move up in the menu.
- Press **F1** to escape and move up in the menu

Scale Menu

See [Scale](#) on page 46

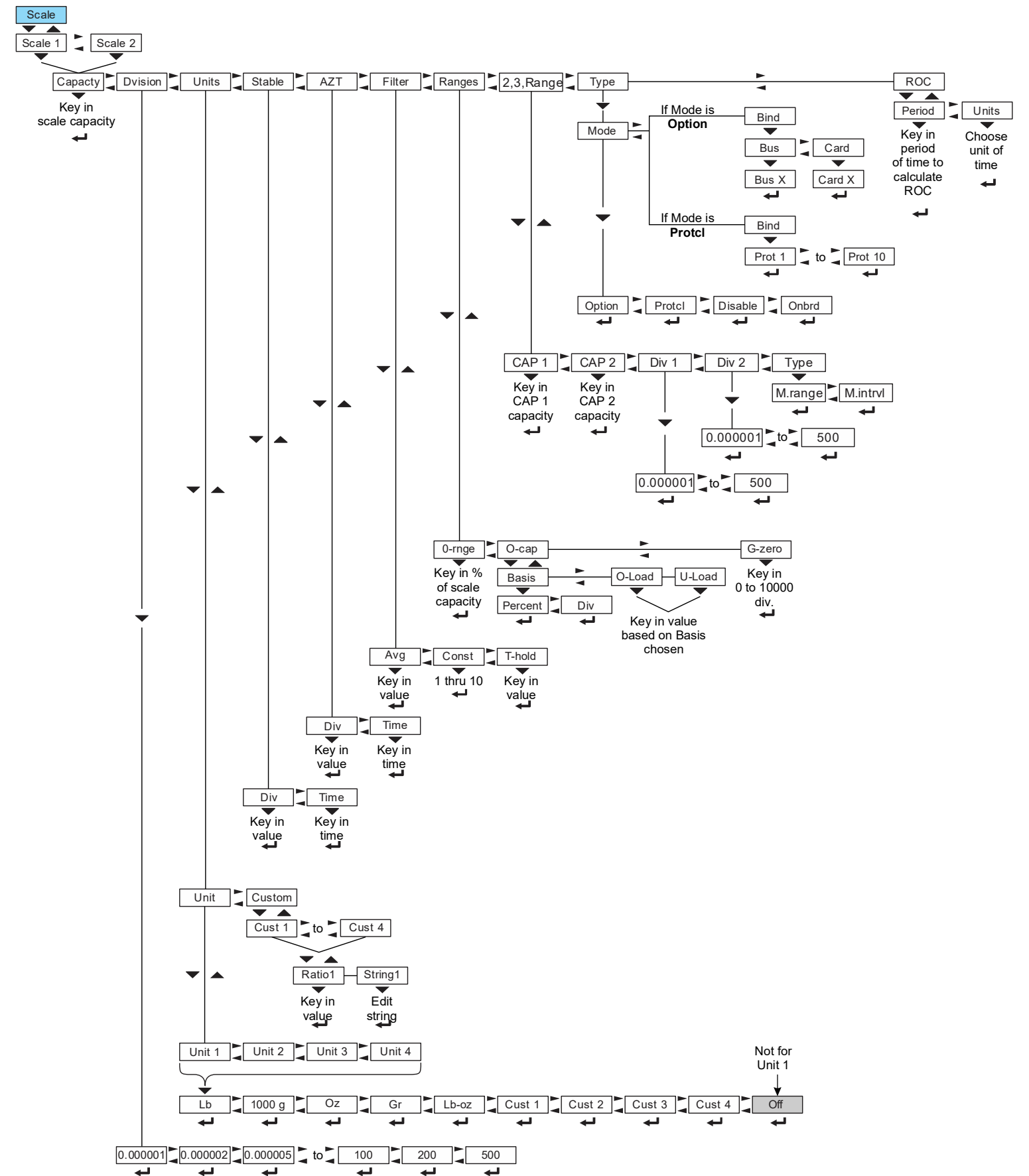

System Menu

See [System](#) on page 55

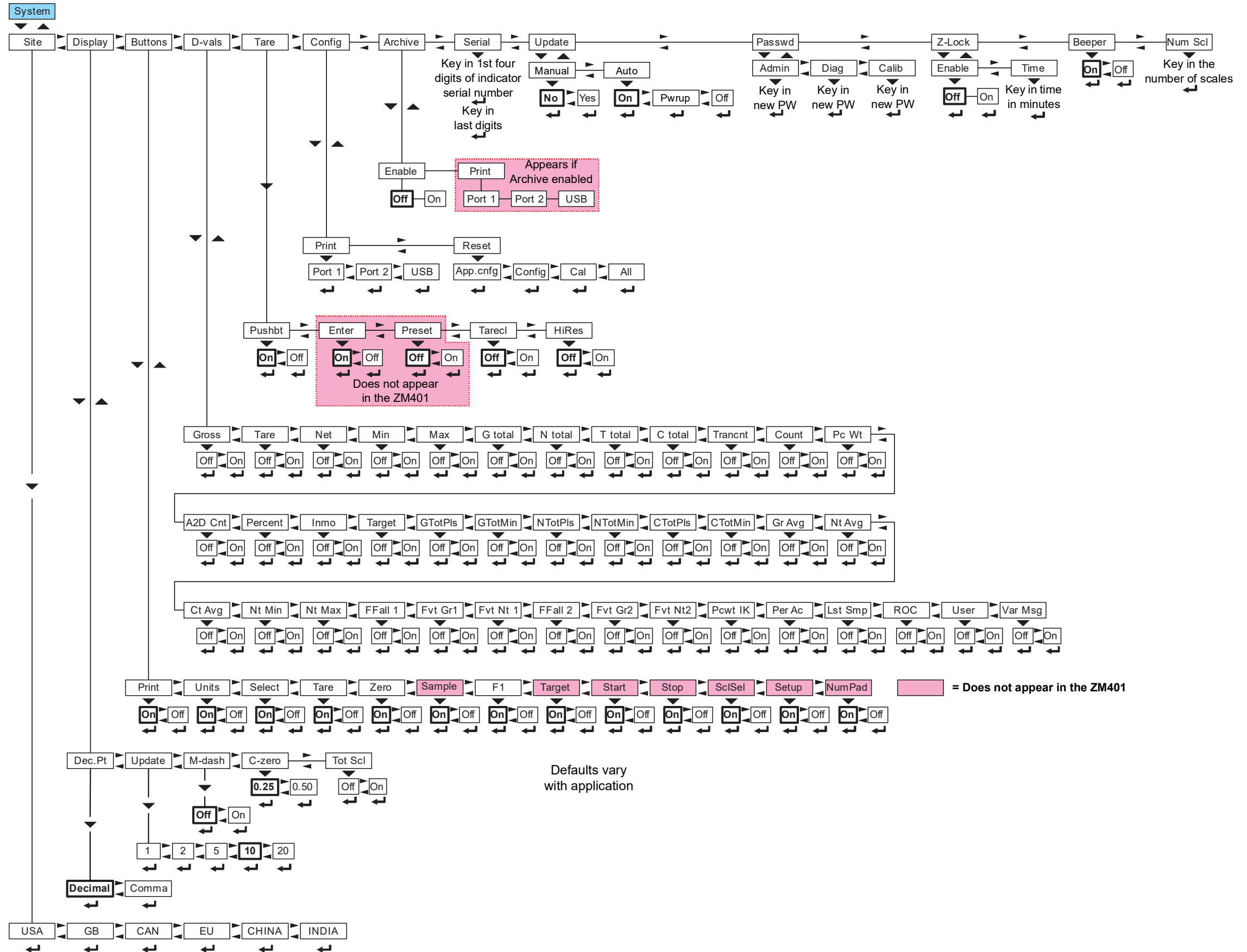

Ports Menu

See [Ports](#) on page 66

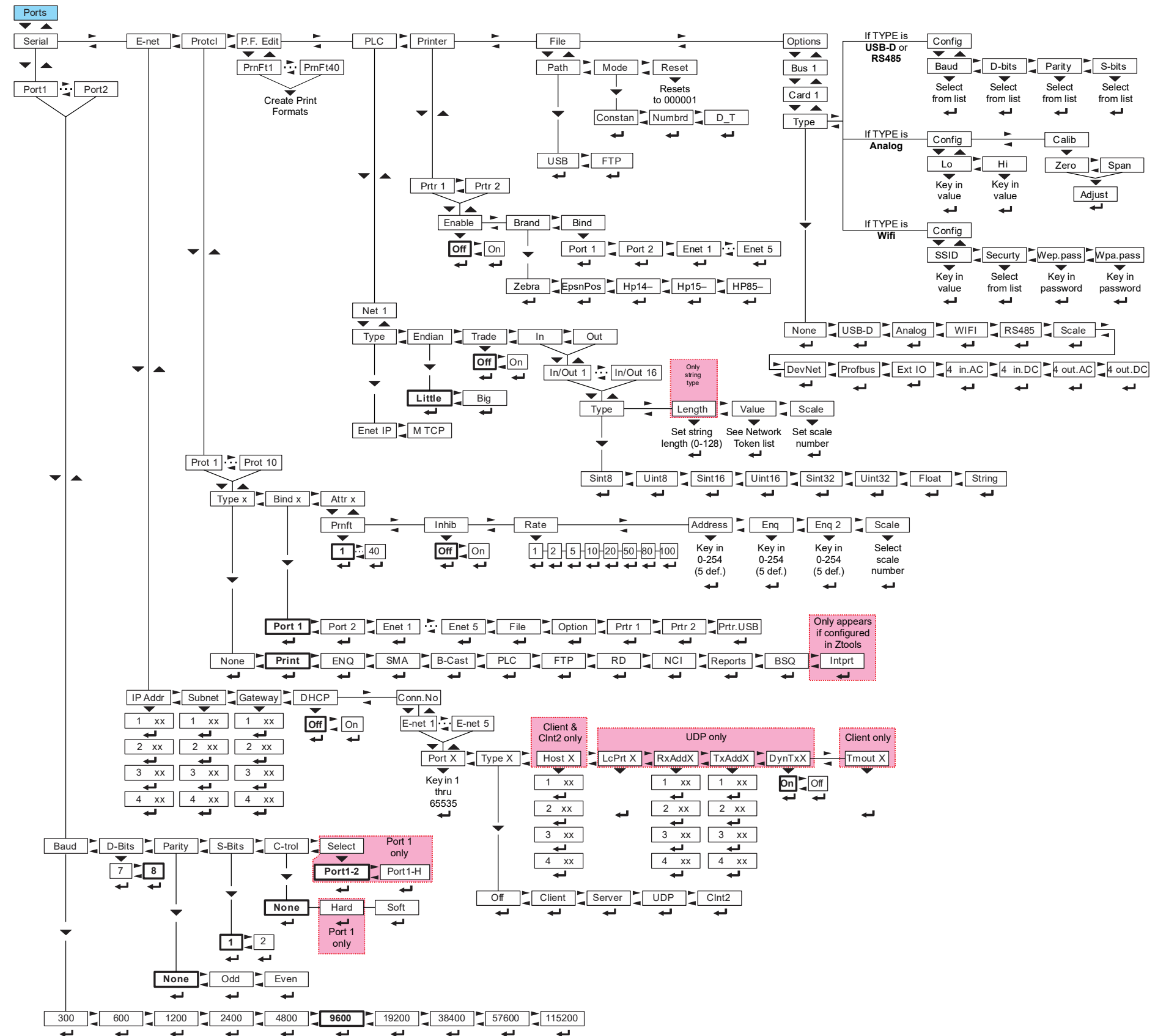

13 Technical illustrations

13.1 Stainless steel enclosure assembly

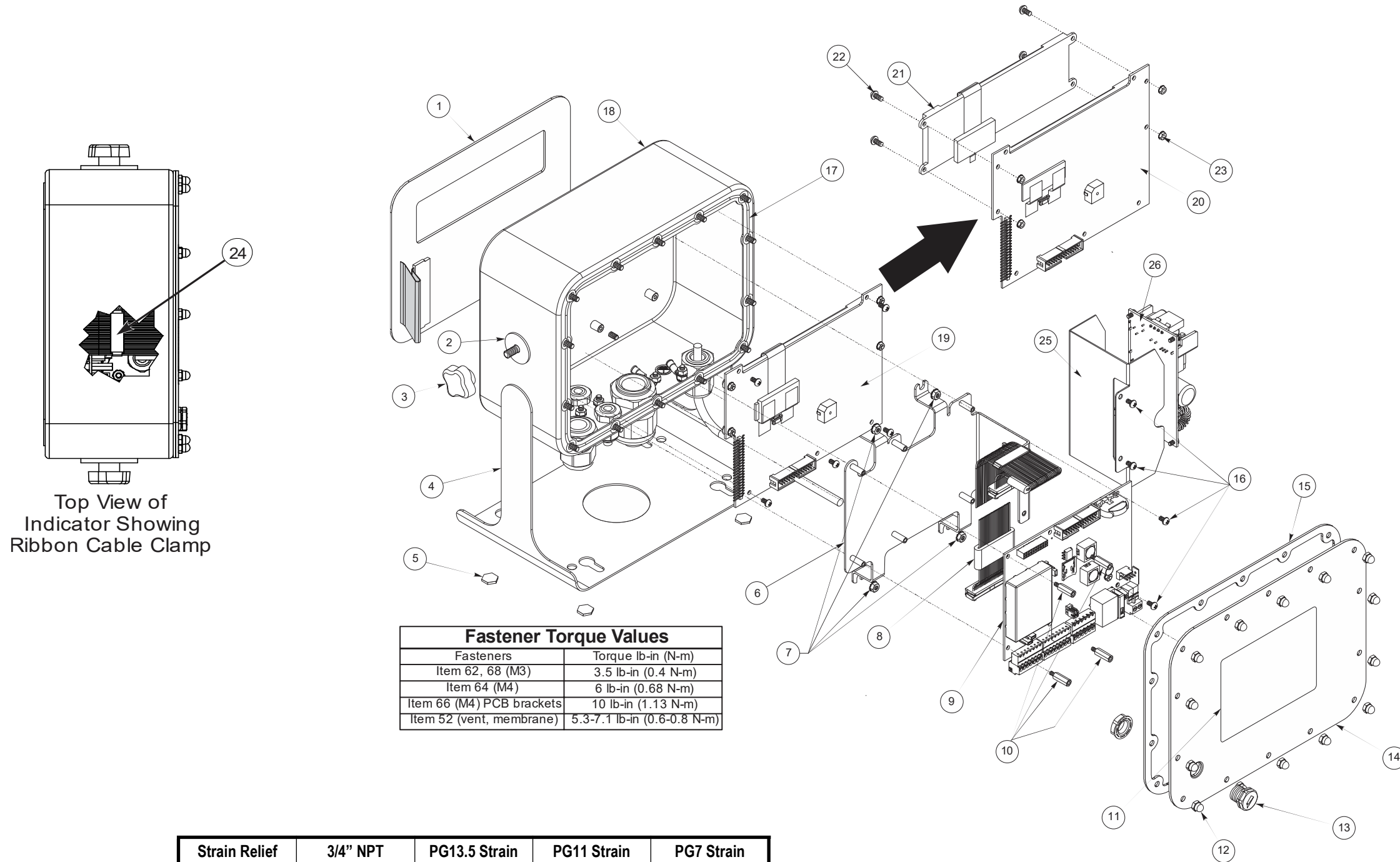

Top View of Indicator Showing Ribbon Cable Clamp

Fastener Torque Values	
Fasteners	Torque lb-in (N-m)
Item 62, 68 (M3)	3.5 lb-in (0.4 N-m)
Item 64 (M4)	6 lb-in (0.68 N-m)
Item 66 (M4) PCB brackets	10 lb-in (1.13 N-m)
Item 52 (vent, membrane)	5.3-7.1 lb-in (0.6-0.8 N-m)

Strain Relief Torque Specs	3/4" NPT Strain Relief	PG13.5 Strain Relief	PG11 Strain Relief	PG7 Strain Relief
Dome Nut	66.4 lb-in 7.5 N-m	33.2 lb-in 3.75 N-m	33.2 lb-in 3.75 N-m	22.1 lb-in 2.5 N-m
Lock Nut	44.2 lb-in 5 N-m	22.1 lb-in 2.5 N-m	22.1 lb-in 2.5 N-m	14.4 lb-in 1.62 N-m

ITEM	DESCRIPTION	QTY
1	OVERLAY KEYPAD, MODEL ZM40x	1
2	PAD, NEOPRENE-1.00 DIA	2
3	KNOB, 4 LOBE-M6	2
4	STAND, ENCLOSURE ZM400	1
5	LOSKID7/16"HEX, 1/16"THK W/9672	4
6	BRACKET, PC BOARD ZM4XX1	1
7	NUT,M4 W/EXT LOCK WASHER SST	11
8	CABLE ASSY MAIN/DSPL INTFC ZM	1
9	PCB ASSY, MAIN ZM305/4XX	1
10	STANDOFF, HEX M3 x 0.5mm x 14mm M/F SST	4
11	LABEL, BLANK	1
12	NUT, ACORN-M4,LOWER-CHAMFER	14
13	VENT, MEMBRANE GREY W/NUT	1
14	PLATE, ENCLOSURE BACK1	1
15	GASKET, UNIVERSAL ZM3XX1	1
16	SCREW, MACH PH M3x0.5x6mm SST	13
17	SEALANT, DOW CORNING 748	4 mL
18	ENCLOSURE, WELDMENT ZM4XX	1
19	DISPLAY/PCB ASSEMBLY	1
20	DISPLAY PCB	1
21	DISPLAY	1
22	SCREW, SEMS, M3.0 X 0.5 X 8mm	4
23	NUT,M3 W/EXT LOCK WASHER SST	6
24	CABLE CLAMP, ALUMINUM FLAT	1
25	SHIELD, POWER SUPPLY-ZM4XX	1
26	POWER SUPPLY, 100-240VAC 65W 24V	1

CAUTION: The acorn nuts holding the back plate of the indicator in place must each be tightened, in multiple passes, in a criss-cross pattern to a final torque of 0.68 N-m (approximately 6 in-lbs) to ensure proper gasket sealing. See illustration of the tightening pattern in [Torque specifications](#) on page 10

13.2 Stainless steel enclosure parts kits

AWT05-506055 - Universal Hardware Kit (Parts appear in one or more ZM400 body styles)	
Description	Qty.
LOSKID7/16"HEX,1/16"THK W/9672	10
SPACER,RD-3.2MMID X 3.0MM LG	10
SCREW, FHD MACH M3X.5X5MM LG	20
NUT,M3 W/EXT LOCK WASHER	30
SCREW/WASHER ASSY M3.0X0.5X8MM	20
SCREW, M3 x.5 6mm LG SEMS PHILIPS PAN HEAD	65
SCREW, M3x10mm LONG	10
STANDOFF,HEX M3X0.5X14mm M/F	20
SPACER, FOAM	5
AC4 NYL.BLK ARROW CLIP	2
SCREW,MACH P/HD M4X12MM SST	4
STANDOFF,HEX M3X0.5X14mm M/F	4

AWT05-507911: Knobs and Pads Kit	
Description	Qty.
KNOB, 4 LOBE-M6	10
PAD, NEOPRENE-1"DIA	10

AWT05-508302: Enclosure Subassembly ZM401 SST	
Description	Qty.
ENCLOSURE, WLEDMENT, ZM4XX	1
OVERLAY, KEYPAD-MODEL ZM401	1

AWT05-508303: Enclosure Subassembly ZM405 SST	
Description	Qty.
ENCLOSURE, WLEDMENT, ZM4XX	1
OVERLAY, KEYPAD-MODEL ZM405	1

T05-800098 Gasket Kit, AW	
Description	Qty.
GASKET, UNIVERSAL ZM2XX,ZM300,4ZM00 REAR GASKET	5

AWT05-506052 - SS Hardware kit		
Item # (page 139)	Description	Qty.
2	PAD,NEOPRENE-1"DIA	10
3	KNOB, 4 LOBE-M6	10
7	NUT,M4 W/EXT LOCK WASHER	55
13	VENT,MEMBRANE GREY W/NUT	5
	CABLE CLAMP	5
	WASHER,RUBBER,BLUE	10
	TIE,CABLE	5

Common Parts			
Item # (page 139)	PN	Description	Qty.
	AWT25-501095	CABLE ASSY, POWER ALLOY ZMXXX	1
8	AWT25-501168	CABLE ASSY MAIN/DSPL INTFC ZM	1
	AWT05-509160	MAIN PC PROGRAMMED BOARD KIT	1
21	AWT05-508532	DISPLAY ONLY, ZM4XX KIT	1
20	AWT05-508535	DISPLAY PCB KIT	1
1	AWT05-508528	OVERLAY, KEYPAD, ZM401 KIT	1
1	AWT05-508529	OVERLAY, KEYPAD, ZM405 KIT	1

AWT05-506054 - Kit, M4 ACORN NUT	
PN	Qty.
NUT, ACORN-M4	100

AWT05-506301 - Kit Service Connectors for ZM Indicator	
DESC	QTY
TERMINAL BLOCK,PLUG 2 PIN	1
TERMINAL BLOCK, 7 POS PLUG PHOENIX ONLY	1
TERMINAL BLOCK 6 POS PLUG 3.8	1
TERMINAL BLOCK 8 POS PLUG 3.5	1

Stainless steel enclosure parts			
Item # (page 139)	PN	Description	Qty.
4	AWT20-505480	STAND, ENCLOSURE ZM4xx	1
6	AWT05-508533	BRACKET, PC BOARD ZM4xx KIT	1
25	AWT20-505670	SHIELD, POWER SUPPLY-ZM4xx	1
26	AWT25-501098	POWER SPLY 100-240VAC 65W 24V	1
NA	AWT25-501063	CABLE ASSY, ZMXXX POWER SUPPLY	1
NA	AWT25-501064	POWER CORD KIT, ZMXXX NA	1
NA	AWT25-501162	WIRE GND ZM PWR SUPPLY TO CHAS	1
15	AWT20-505668	GASKET, UNIVERSAL ZM400	1
14	AWT05-800086	KIT, BACK PLATE, ZM3XX/4XX	1
NA	AWT25-501072	WIRE, GROUND ZMXXX SERIES	1

AWT05-506053 - Strain Relief Kit for Stainless steel enclosure		
Item # (page 139)	Description	Qty.
32	O-RING PG 13.5 BUNA-N	5
34	O-RING 3/4" NPT BUNA-N	5
33	PG7 'O' RING SEAL:HUMMEL OR-07	10
33	STRAIN RELIEF,PWR CORD .11-.26	10
32	STRAIN RELIEF,PWR CORD .24-.47	5
33	NUT,LOCK STR RELIEF PG7 THR'D	10
32	NUT,LOCK STR RELIEF PG13.5 THR	5
34	STRAIN RELIEF,PWR CORD .39-.62	5
	CORD,BLACK NEOPRENE - .25" DIA	5
	CORD,BLACK NEOPRENE - .62" DIA	5

AWT05-508874 - Kit, GORETEX Vent	
Description	Qty.
VENT, MEMBRANE GREY W/NUT	10

13.3 Panel mount enclosure parts and assembly

Fastener Torque Values	
Fasteners	Torque lb-in (N-m)
Item 17, 18, 20, 22, & 24 (M3)	3.5 lb-in (0.4 N-m)

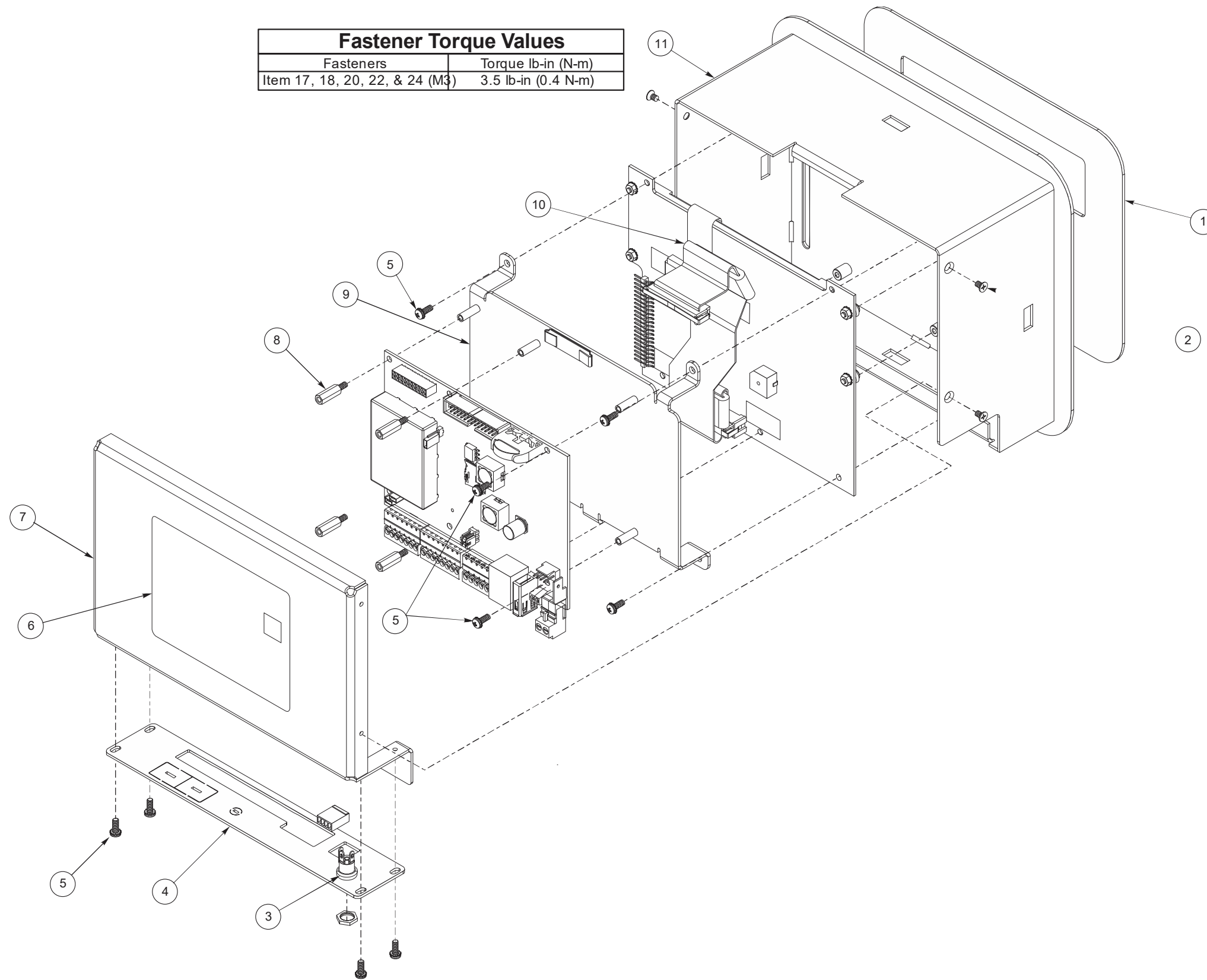

ITEM	DESCRIPTION	QTY
1	OVERLAY KEYPAD, MODEL ZM40x	1
2	SCREW, FHD MACH M3x.5x5mm LONG	4
3	CABLE, ASSY, POWER ALLOY ZMXXX	1
4	PLATE, COVER PCB-PANEL MOUNT	1
5	SCREW, SEMS, M3.0 X 0.5 X 8mm	15
6	LABEL, BLANK	1
7	COVER, REAR-PANEL MOUNT	1
8	STANDOFF, HEX M3 x 0.5mm x 14mm M/F SST	4
9	BRACKET, PC BOARD, PM w/STANDOFFS	1
10	CABLE ASSY MAIN/DSPL INTFC ZM	1
11	BACKER PLATE/COVER WELD ZM4XX	1

13.4 Panel mount enclosure parts lists

AWT05-506055 - Universal Hardware Kit	
Description	Qty.
LOSKID7/16"HEX,1/16"THK W/9672	10
SPACER,RD-3.2MMID X 3.0MM LG	10
SCREW, FHD MACH M3X.5X5MM LG	20
NUT,M3 W/EXT LOCK WASHER	30
SCREW/WASHER ASSY M3.0X0.5X8MM	20
SCREW, M3 x.5 6mm LG SEMS PHILIPS PAN HEAD	65
SCREW, M3x10mm LONG	10
STANDOFF,HEX M3X0.5X14mm M/F	20
SPACER, FOAM	5
AC4 NYL.BLK ARROW CLIP	2
SCREW,MACH P/HD M4X12MM SST	4
STANDOFF,HEX M3X0.5X14mm M/F	4

AWT05-509172 - Panel Mount Kit with Medium Brkt/Blks	
Description	Qty.
PLATE, BASE TORQUE-PANEL MOUNT	1
GASKET, FRONT PLATE PANEL MNT	1
BLOCK, TENSION	4
SCREW, M6X1 45MM LG SST P/PH	6

Parts for Panel Mount Enclosure			
Item # (from page 141)	PN	Description	Qty.
7	AWT20-506125	COVER, REAR, PANEL MOUNT	1
9	AWT20-508301	BRACKET, PCB PM W/STDOFF KIT	1
4	AWT20-508081	PLATE, COVER PCB-PANEL MOUNT	1
	AWT20-508439	DECAL ZM4XX REAR PLATE PNL MTG	1
	AWT05-508532	DISPLAY, SEGMENT/CHARACTER IBN KIT	1
	AWT05-508529	KEYPAD, ZM405 KIT	1
	AWT05-508528	KEYPAD, ZM401 KIT	1

Common Parts		
AWT25-501095	CABLE ASSY, POWER ALLOY ZMXXX	1
AWT25-501168	CABLE ASSY MAIN/DSPL INTFC ZM	1
AWT25-501234	SPACER, CARD ENGINE ZM SERIES	1
AWT05-800082	PCB ASSY, CARD ENGINE MCF54450 KIT	1

AWT05-508305: Enclosure Subassembly ZM405 PANEL MOUNT	
Description	Qty.
BACKER PLATE/COVER WELD ZM4XX	1
OVERLAY, KEYPAD-MODEL ZM405	1

AWT05-508304: Enclosure Subassembly ZM401 PANEL MOUNT	
Description	Qty.
BACKER PLATE/COVER WELD ZM4XX	1
OVERLAY, KEYPAD-MODEL ZM401	1

13.5 System block diagram

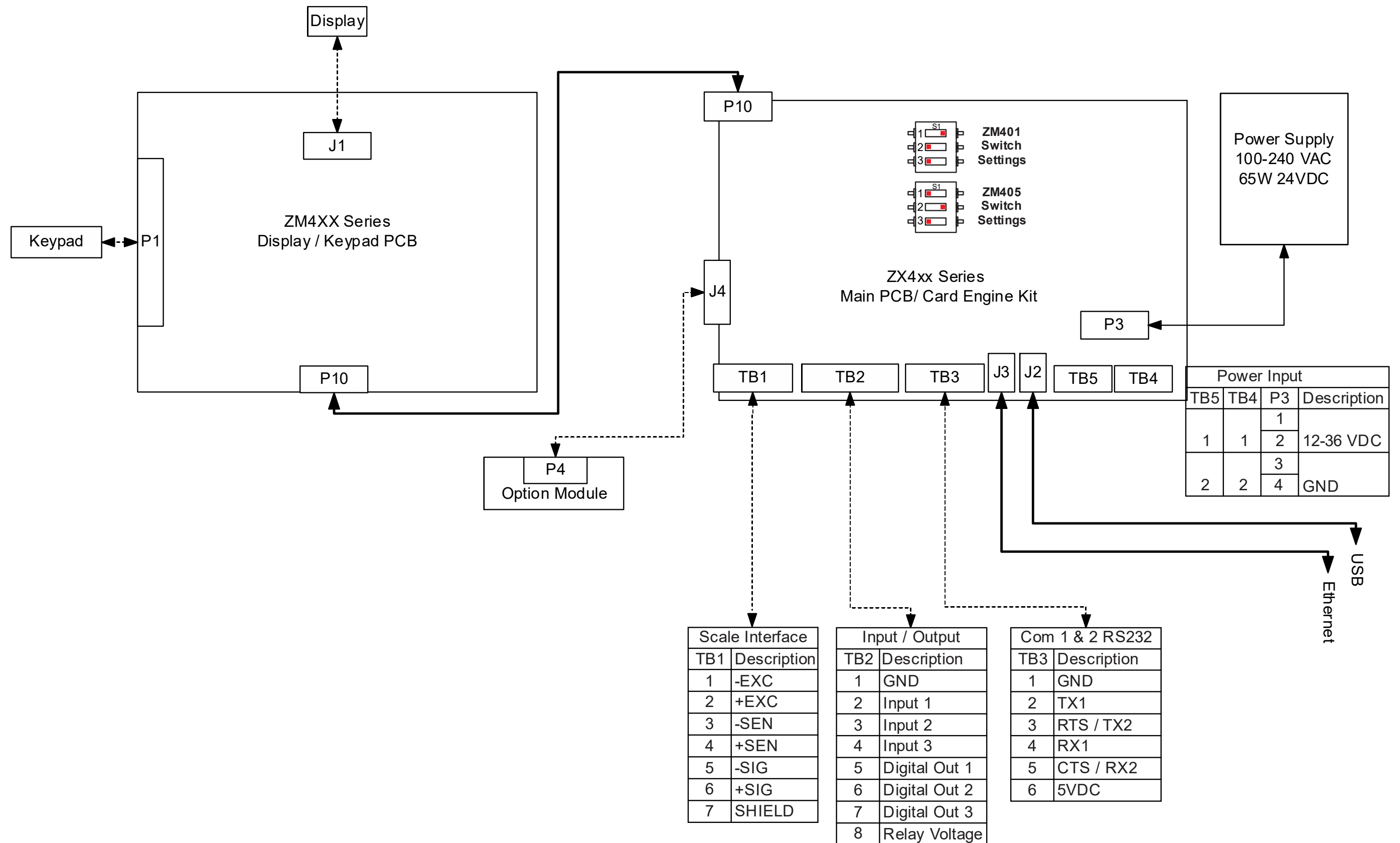

13.6 ZM jumper and switch settings

ZM4xx Main PC board

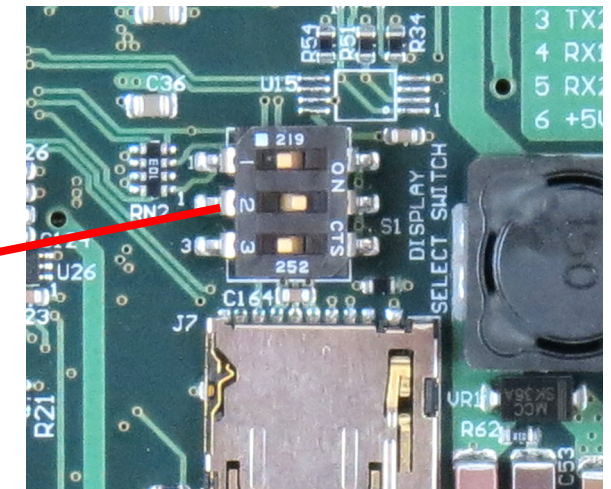
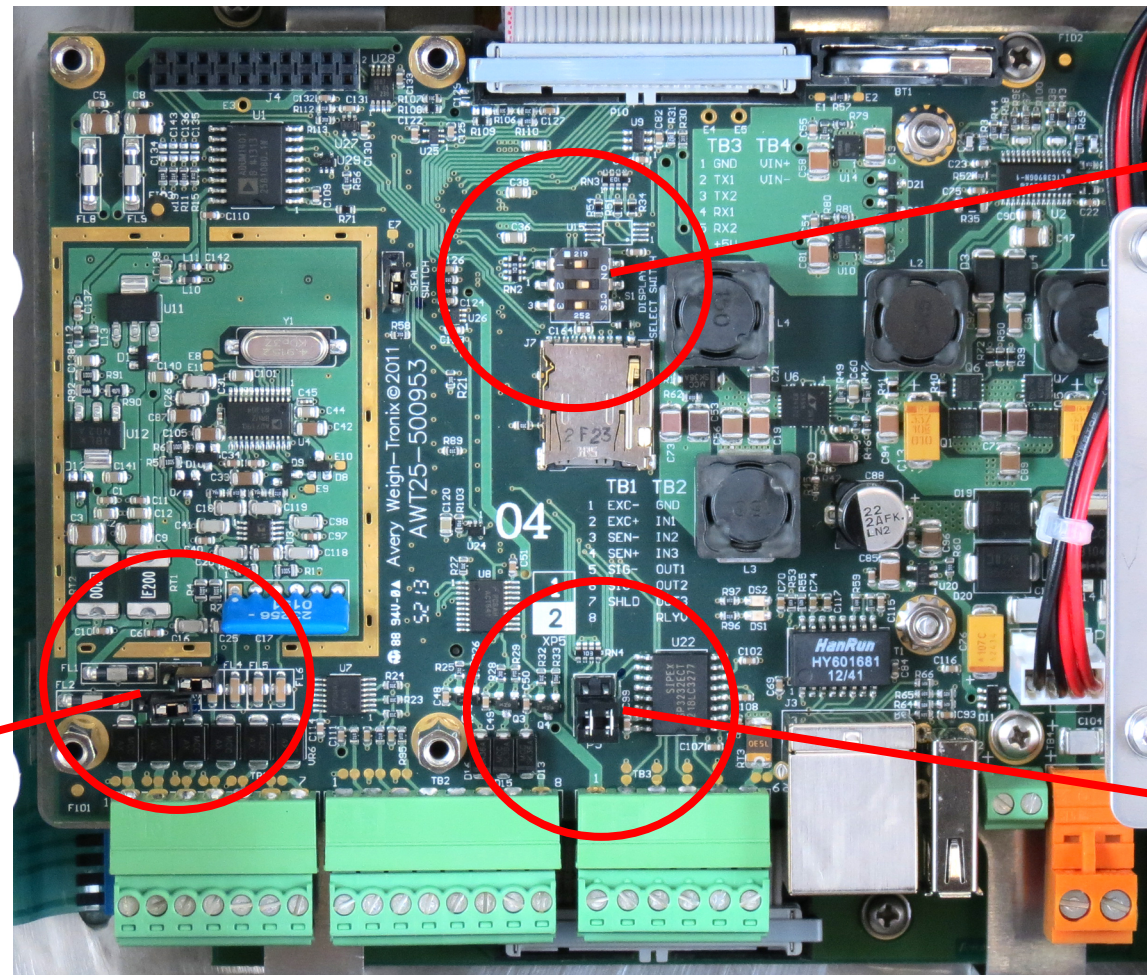

Model Select Switch

See the settings for these switches in the [System block diagram on page 143](#).

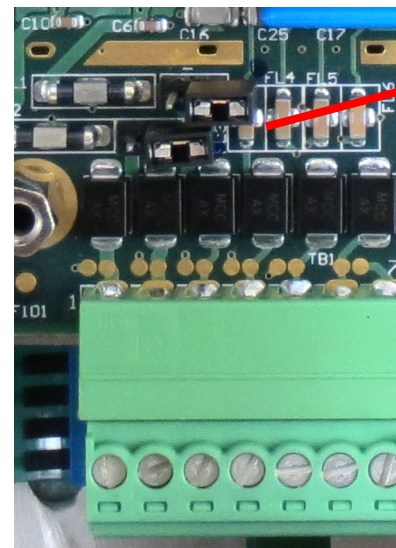

Sense (Excitation) jumpers shown in the unjumped position.

4 wire loadcells require jumper.
6 wire loadcells do not require jumper.

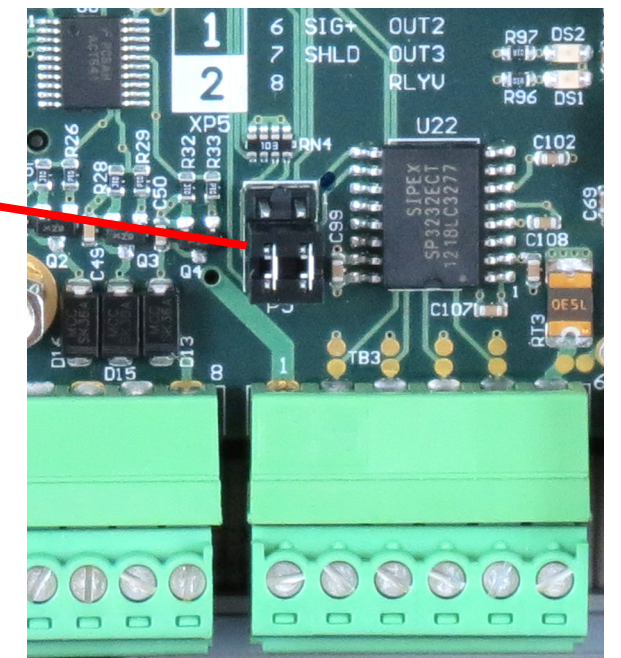

Flow control jumper

Jumper shown in position 2 (default) for 2 comm ports.

Position 1 = Hardware flow control for port 1.

13.7 ZM remote inputs and outputs, Opto-22 module

USING EXTERNAL DC VOLTAGE TO OPERATE RELAYS

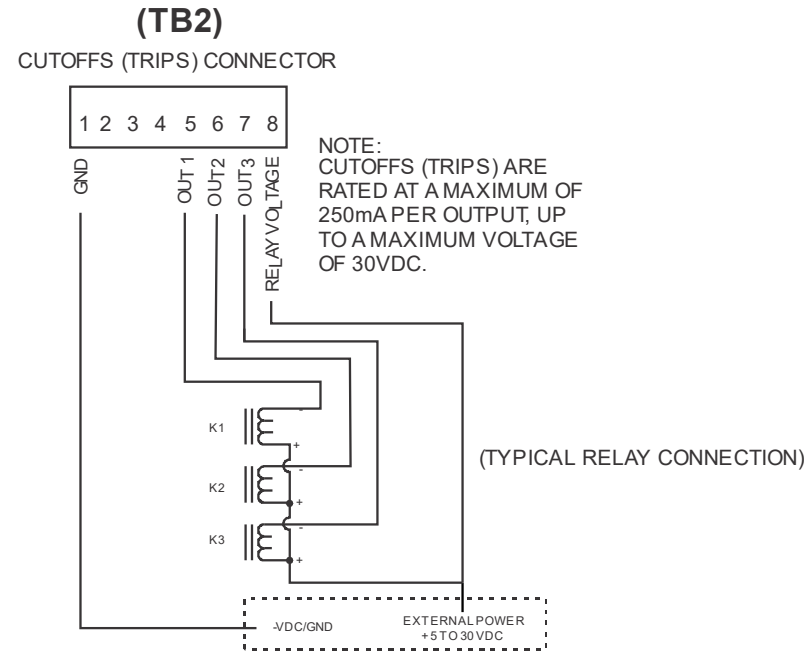

USING INTERNAL +5VDC VOLTAGE TO OPERATE RELAYS

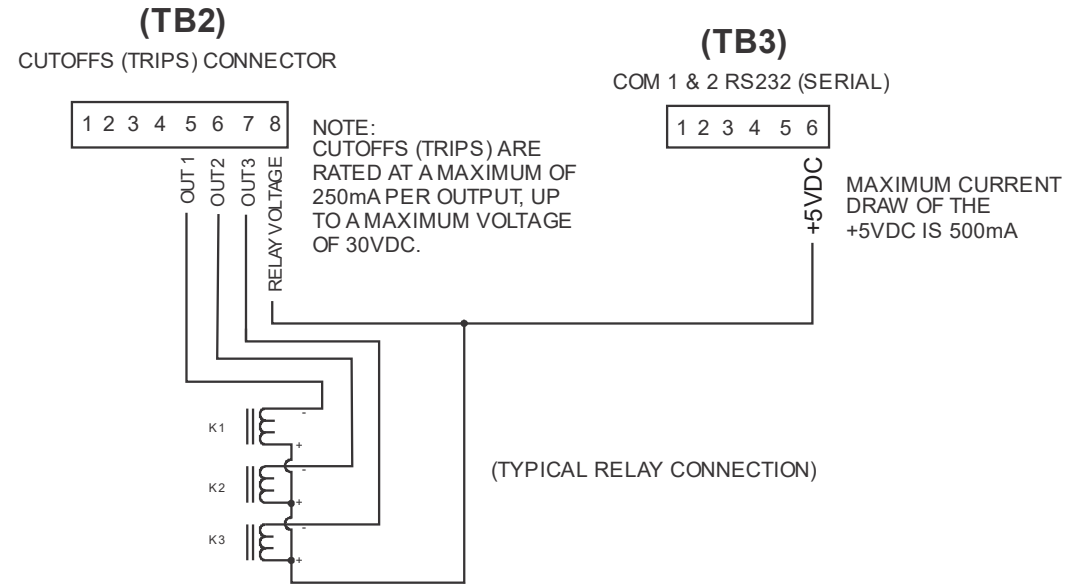

USING INTERNAL +24VDC VOLTAGE TO OPERATE RELAYS

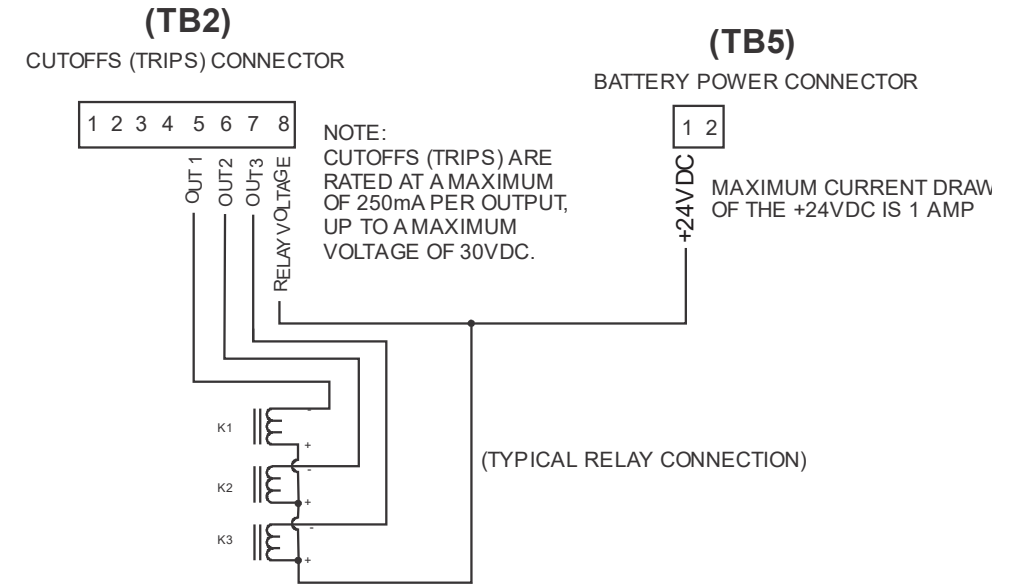

WARNING: EXCEEDING ANY OF THE CURRENT LIMITS OR VOLTAGE MAXIMUMS WILL DAMAGE THE INDICATOR.

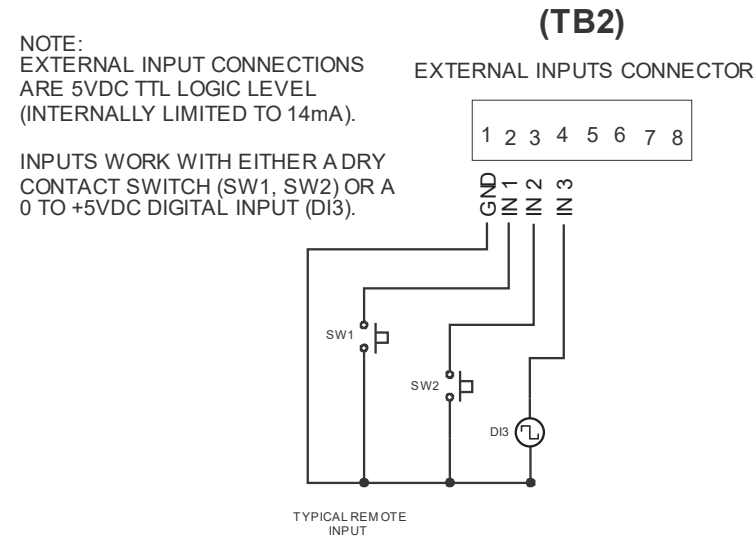

ZM Opto Box Wiring Information

Indicator TB2-1 Ground	↔	ZM Opto Box TB1-1
Indicator TB2-2 Input 1	↔	ZM Opto Box TB1-7
Indicator TB2-3 Input 2	↔	ZM Opto Box TB1-6
Indicator TB2-4 Input 3	↔	ZM Opto Box TB1-5
Indicator TB2-5 Output 1	↔	ZM Opto Box TB1-4
Indicator TB2-6 Output 2	↔	ZM Opto Box TB1-3
Indicator TB2-7 Output 3	↔	ZM Opto Box TB1-2
Indicator TB2-8 Relay Voltage/+5VDC	↔	ZM Opto Box TB1-8
Indicator TB2-8 Relay Voltage/+5VDC	↔	Indicator TB3-6

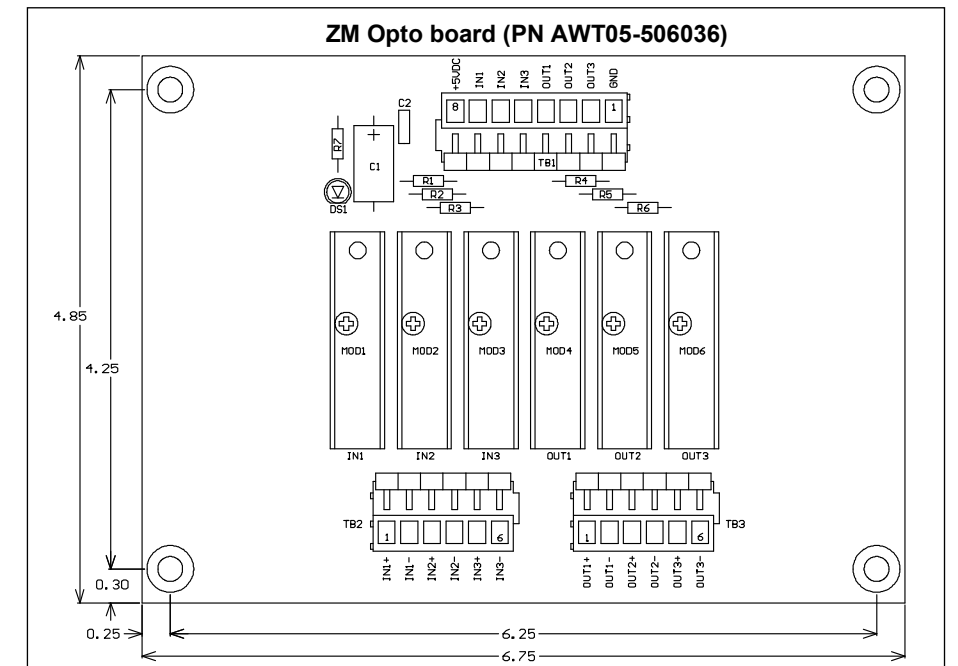

13.8 STVS (Severe Transient Voltage Suppressor) installation

The STVS kit is used to suppress high voltages before they can damage the components of the indicator. Use these instructions to install the STVS module.

1. Disconnect the indicator from power.
2. Remove the acorn nuts from the back panel and carefully remove the back. Be sure not to stretch or damage the ground wire connected to the inside of the back panel.
3. There are four studs on the inside the back cover. Mount the STVS module to the studs as shown in the photos below. Use the supplied screws. The module should be vertical on the back plate with the IN marked connector positioned closer to the Gore® Vent. The OUT side should face up. See the photos below.



4. Attach the scale interface wires to the IN side of the module per the wiring illustration shown below.
5. Use wires of adequate length and connect the OUT side of the STVS module to TB1 on the indicator main board, per the illustration below.
6. Be sure no wires or cables are pinched between the front and back of the indicator as you replace the back panel. Tighten the acorn nuts in the proper fashion.

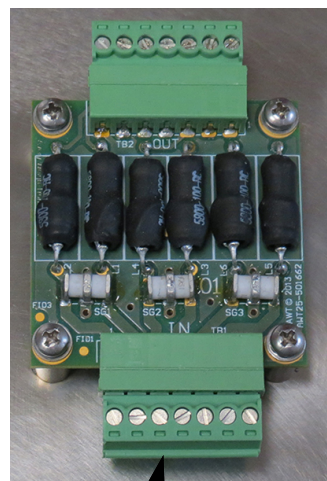
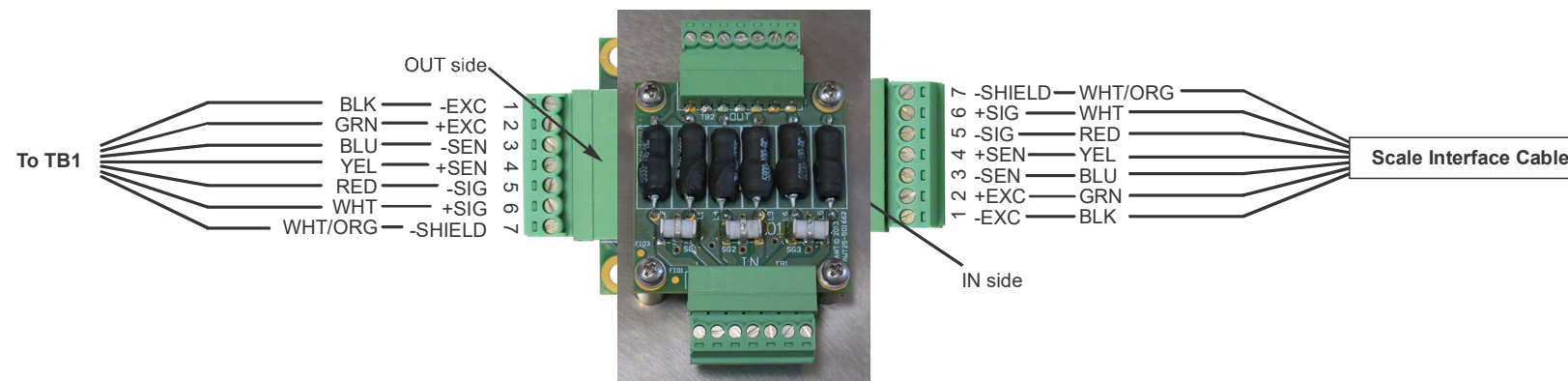

STVS module orientation should be vertical with the side marked IN towards the bottom of the indicator, closer to the Gore Vent.

Attach OUT side of the STVS module to TB1.

Attach incoming scale interface lines to the IN side of the STVS module.

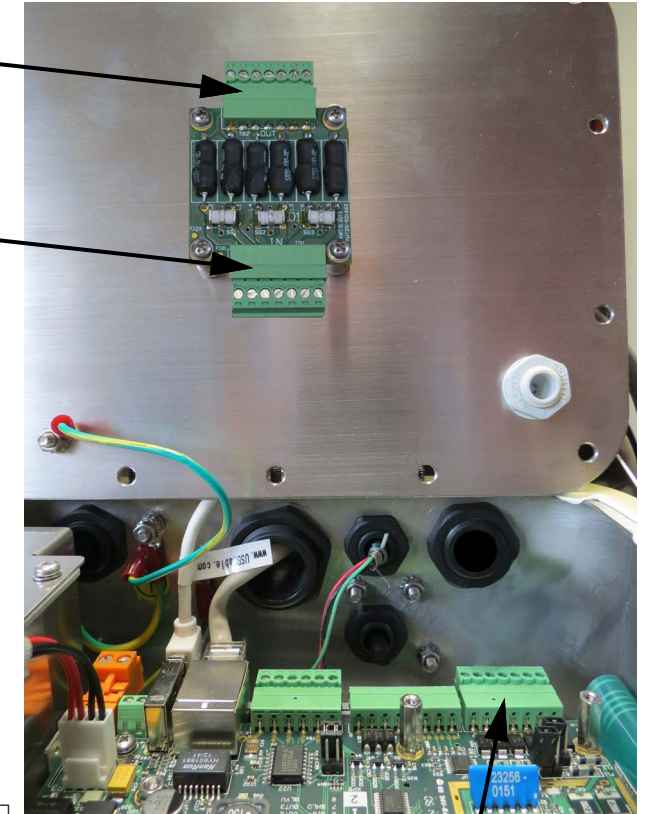

TB1

13.9 Outline dimensions (stainless steel)

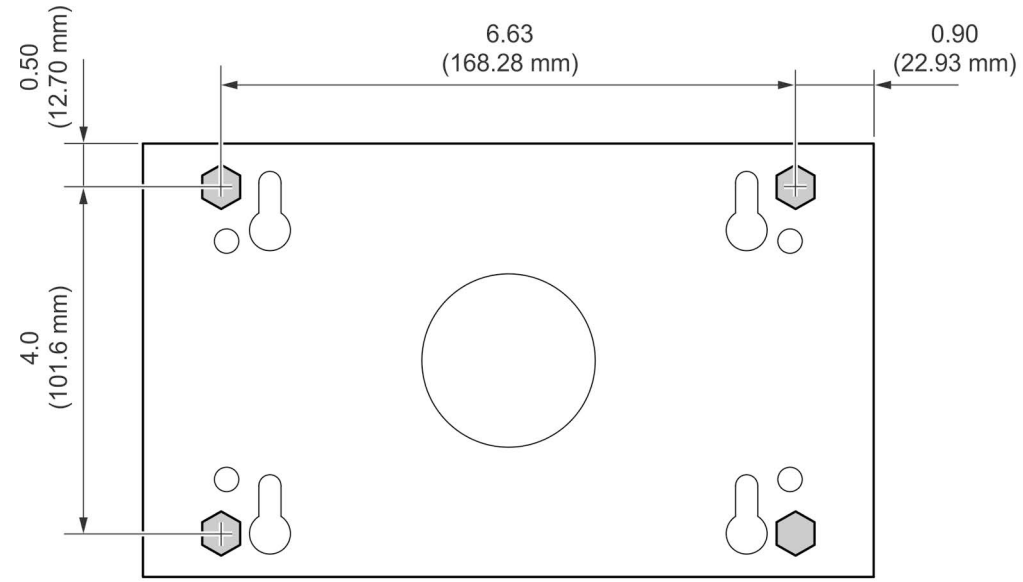

ZM4xx Stainless Steel

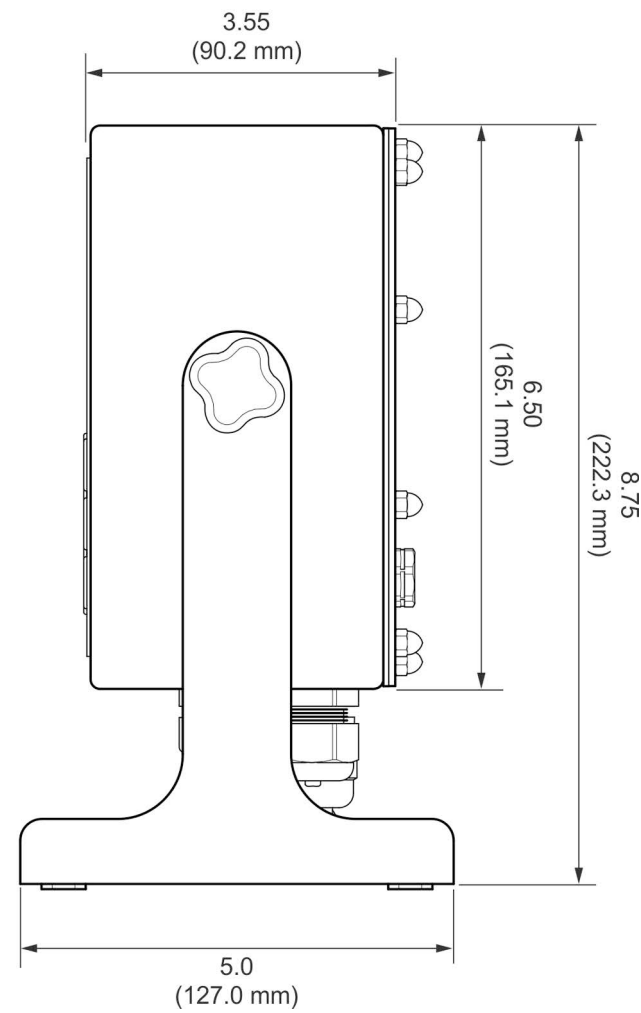
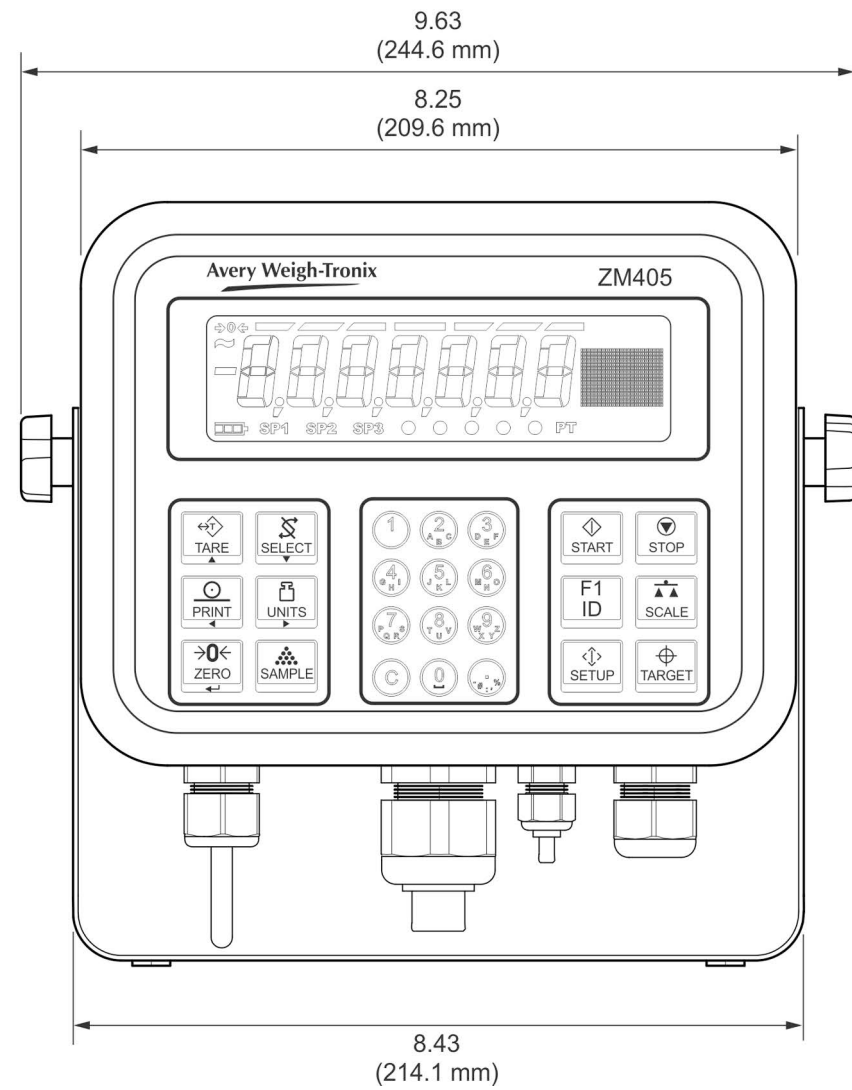

13.10 Outline dimensions (panel mount)

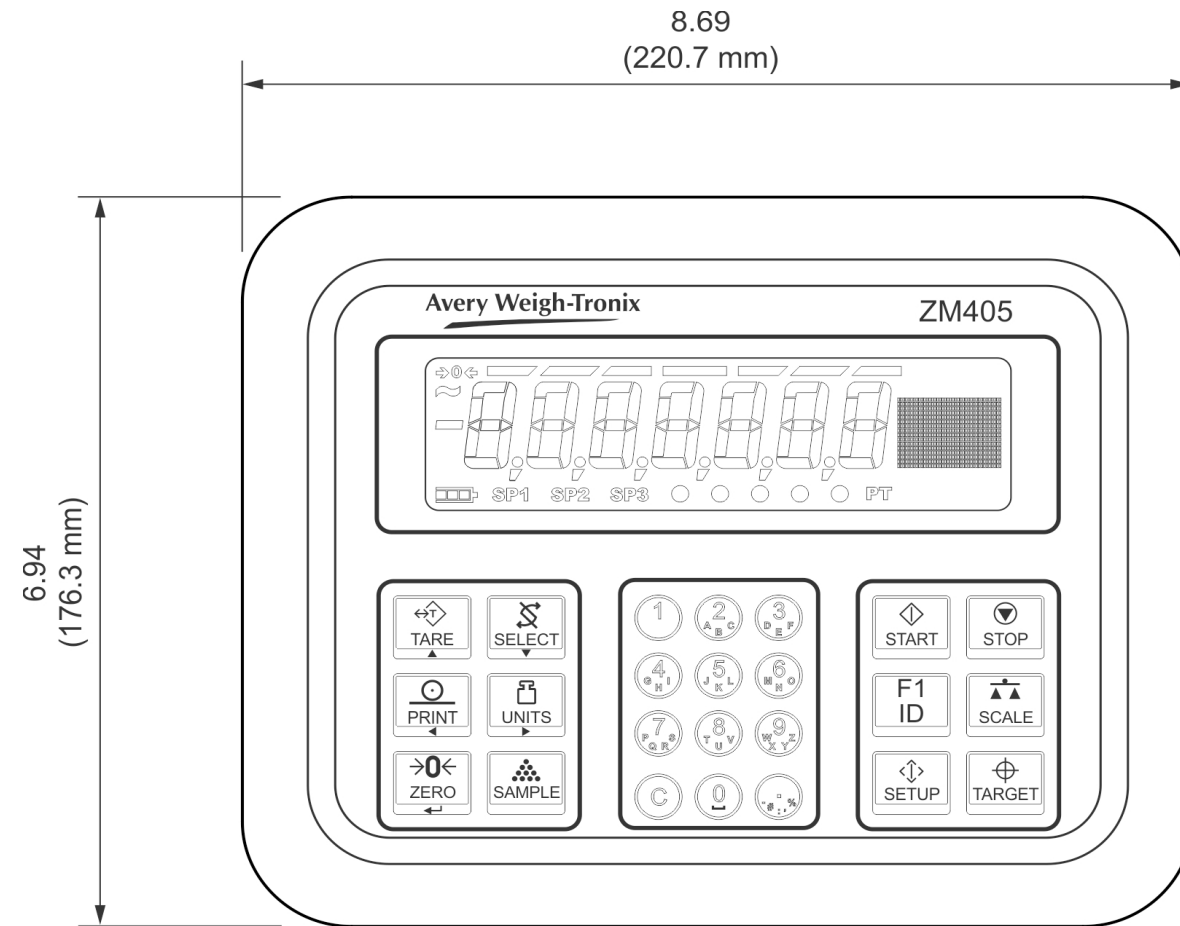

6.94
(176.3 mm)

8.69
(220.7 mm)

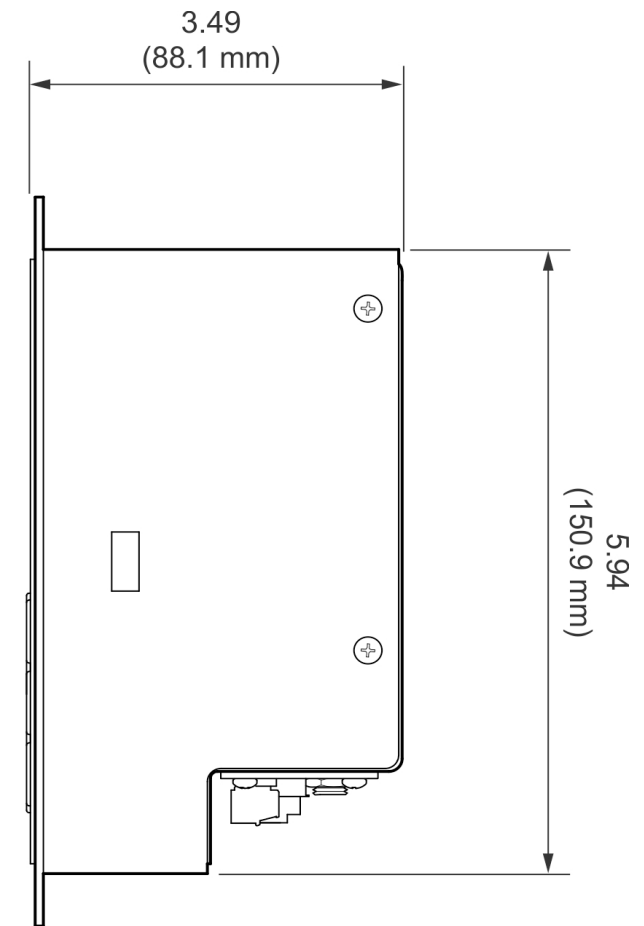

3.49
(88.1 mm)

5.94
(150.9 mm)

ZM4xx Panel Mount

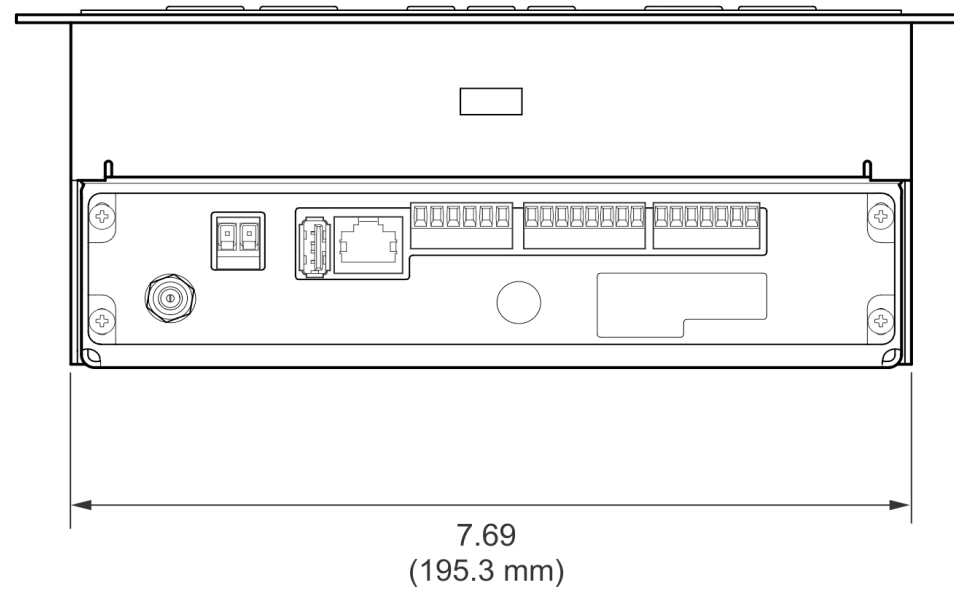

7.69
(195.3 mm)

13.11 Panel mount assembly

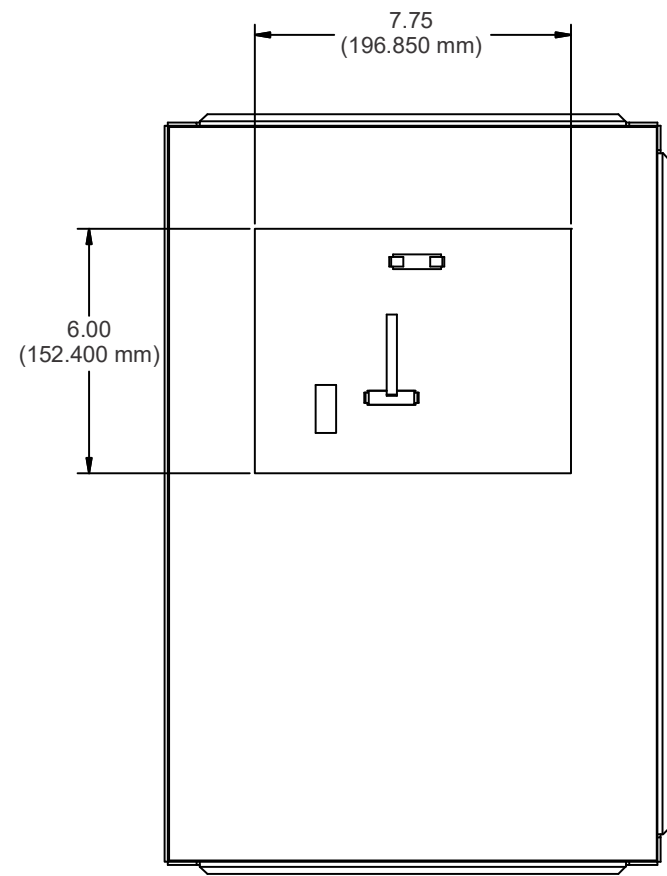

CUTOUT DIMENSIONS

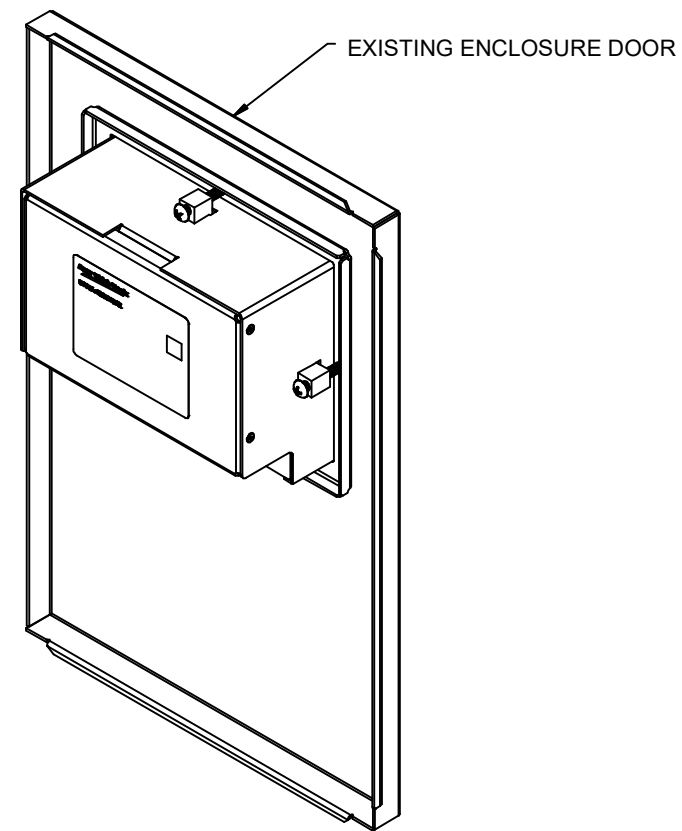

INSIDE VIEW ASSEMBLY

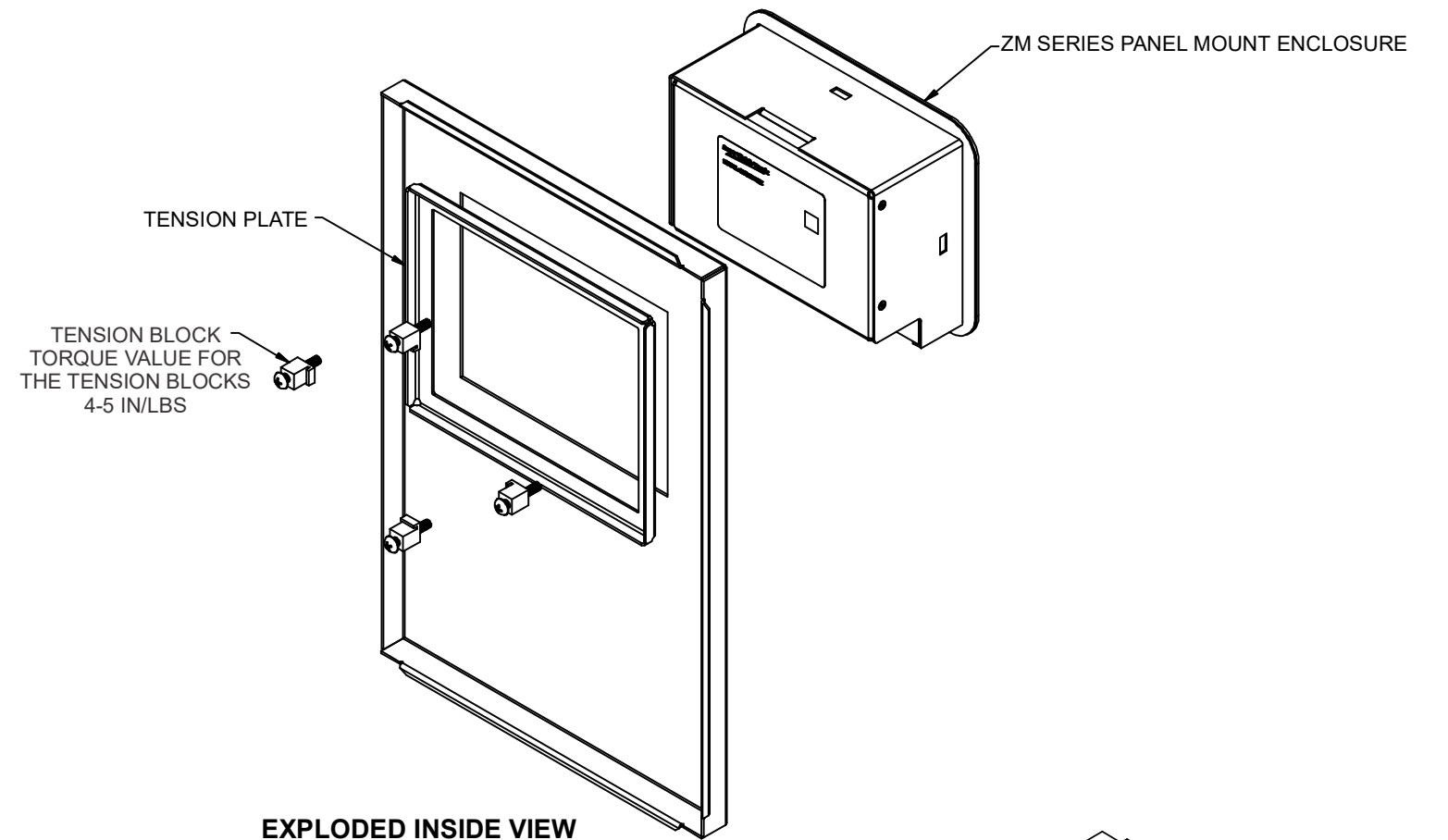

EXPLODED INSIDE VIEW ASSEMBLY

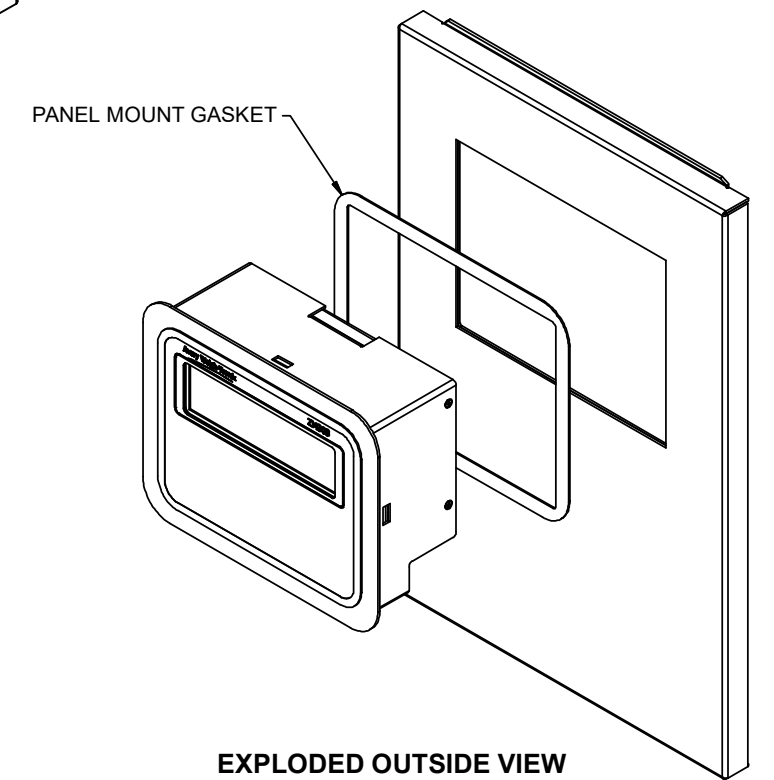

EXPLODED OUTSIDE VIEW ASSEMBLY

13.12 D-cell Battery pack option (AWT05-505852) and external battery circuitry

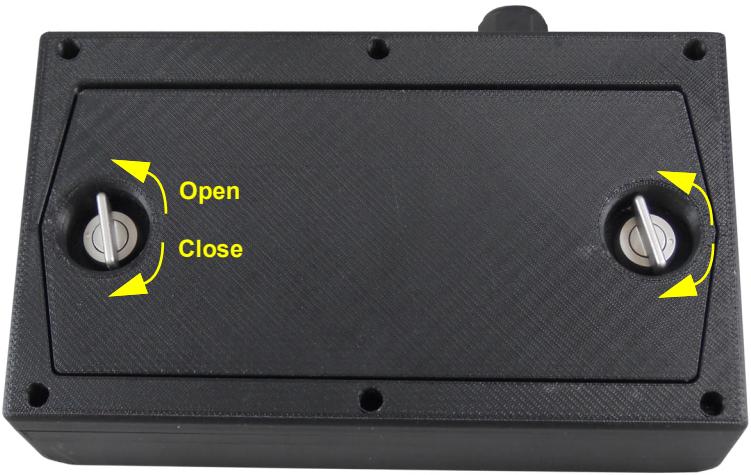

Turn knobs counter clockwise to remove the door.
 Clockwise to secure door in place.



Pass cable through an available gland, attach the wires to the orange connector as described below:
Battery Connections:
 White wire to + side of TB4
 Black wire to - side of TB4.

Internal PC board

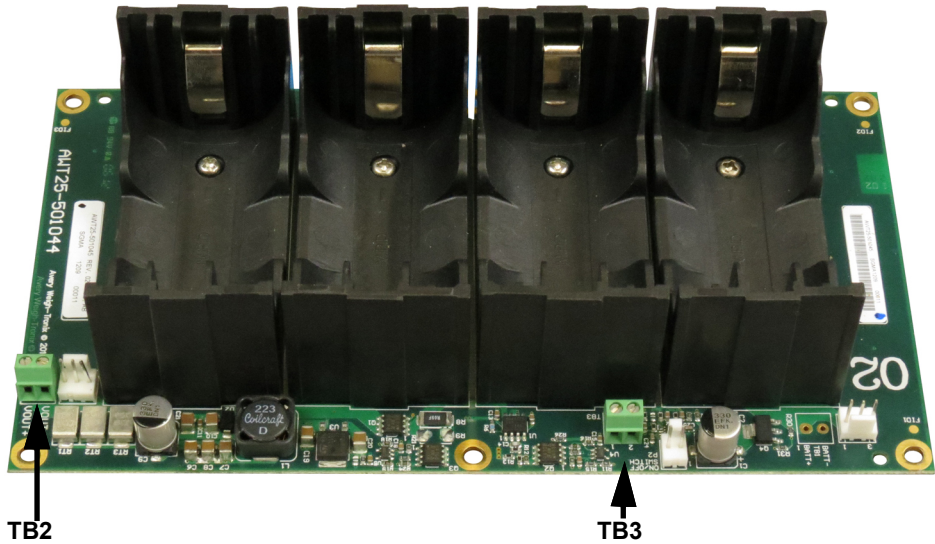

Wiring chart

ZM-BAT PCB	Wire Color	Signal	ZM30x
TB2 - 1	White	+ Volt	TB4 (+)
TB2 - 2	Black	- Volt	TB4 (-)
TB3 - 1	Green	Out3 (sleep)	TB2 - 7

External battery circuit

If you use an external battery for power and wish to take advantage of the auto off function, follow the suggested circuit illustration below.

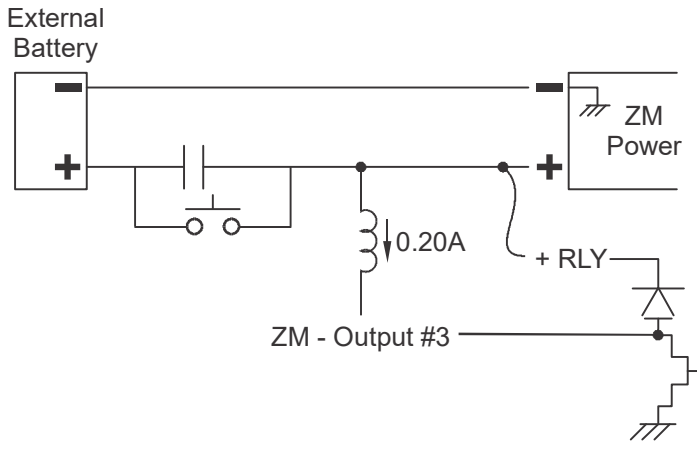

13.13 Keypad overlay replacement procedure

Problems that arise due to the keypad being changed are not covered by any warranty, such as keys not functioning correctly or water ingress through the front panel.

The IP69K rating cannot be guaranteed when changing the keypad overlay. If you are in an environment that requires the IP69K rating, it is advised that you order the keypad/enclosure assembly instead of changing out the keypad.

13.13.1 To change the keypad you will need these tools:

- 1 A razor blade
- 1 A container big enough to place the indicator case in
- 1 Rubbing alcohol.
- 1 A large wooden dowel or wooden kitchen rolling pin.

13.13.2 Process to remove and replace the keypad overlay

1. Open the enclosure and remove all electronic P.C. boards, including the display board.
2. Use the razor blade to remove the old overlay and remove as much of the glue as possible.
3. Place some rubbing alcohol in the container, enough to be able to submerge the front of the enclosure where the keypad was. No more than ½ an inch should be needed.
4. Place the enclosure face down in the rubbing alcohol and soak it for 30 minutes.
5. Use the razor blade to remove all remaining glue.
6. Let the enclosure dry for at least 5 minutes.
7. Place new keypad on the enclosure; ensure that the keypad is aligned correctly.
8. Use rolling pin on the overlay to ensure good contact between the enclosure and the keypad overla

Index

Numerics

- 2,3,Range
 - CAP 1... 52
 - CAP 2... 52
 - DIV 1... 52
 - DIV 2... 52
 - Multi Interval... 53
 - Multi Range... 52
 - tYPE... 52
- 802.11g wireless communication module installation... 97

A

- About menu... 27, 134
 - Bootloader... 28
 - Download... 30
 - Ethernet... 29
 - Firmware... 28
 - Serial number... 28
 - user menu... 27
- AC relay module installation... 98
- Accessing the menus... 17
- ADMIN level menus... 39
- Analog option module... 94
- App... 27
- Application variable token table... 127
- ASCII characters... 129
- Assembly
 - stainless steel enclosure... 139
- Audit menu... 31
 - counter... 31
 - print... 32
- Audit menu structure... 133
- Audit report... 108
- Automatic zero tracking (AZT)... 49
- AWT Extended SMA Commands... 85

B

- Bootloader... 27
- Button test... 35

C

- Cable grounding... 10
- Calibration
 - Alternate zero procedures
 - Input Calibration Procedure... 43
 - linearity... 42
 - span... 42
 - zero... 41
- Calibration menu structure... 135
- Calibration procedure... 40
- Calibration report... 107
- Calibration unit... 45
- Command response... 84
- Communication port protocols... 82
- Complete menu structures... 133
- Configuration report... 107
- Control codes... 130
- Current loop module installation... 95

D

- Data entry... 18
- Date... 25
- D-cell battery pack option... 150
- Default parameter values... 56
- Default print formats... 131
- Diagnostics level menus... 33
- Diagnostics menu... 33
- Diagnostics menu structure... 133
- DIS token... 126
- Display
 - live scale weight... 45
 - system menu... 57
- Display test... 35
- Division
 - scale menu... 47

E

- Edit an existing print string... 110
- ENQ and B-Cast commands... 87
- Error log report... 37, 38
- Errors

- print format... 118
- Ethernet... 97
- Ethernet/IP explicit messaging... 92
- Ethernet/IP implicit messaging... 92
- Exiting the menus... 21
- External battery circuitry... 150

F

- Filter... 50
- Firmware... 27, 28
- Front panel... 14

G

- Gravity factor procedure... 44

I

- Indicator installation... 10
- Inserting tokens... 114
- Installation... 10

J

- Jumper settings... 144

K

- Keypad overlay replacement... 151

L

- Leading zeroes
 - transmit... 117
- Linearity
 - calibration... 42

M

- Mainboard jumper settings... 144
- Mainboard switch settings... 144
- Menu access... 21
- Menu annunciators... 18
- Menu level... 20

- Menu navigation keys... 20
- Menu passwords... 20
- Modbus/TCP... 90

N

- NCI commands... 88
- NCI Status Byte... 126
- Network tokens... 127

O

- Option installation
 - analog output module... 94
- Option modules... 93
 - analog output... 94
 - current loop... 95
 - RS422... 95
 - RS485... 95
- Opto-22 module... 145
- Outline dimensions
 - panel mount enclosure... 148
 - stainless steel enclosure... 147

P

- Panel mount
 - outline dimensions... 148
- Panel mount assembly... 149
- Panel mount enclosure assembly... 141
- Panel mount enclosure parts... 141
- Panel mount enclosure parts lists... 142
- Parameter values
 - default... 56
- Parts kits
 - stainless steel enclosure... 140
- Parts lists
 - panel mount enclosure... 142
- Password... 64
- Passwords... 20
- PLC configuration... 90
- Port menu structure... 138
- Ports menu... 66
 - options... 79
 - P.F.Edit... 74
 - PLC... 74
 - printer... 76

- protocol... 71
- serial... 67
- Powering up the ZM400... 17
- Print
 - edit print string... 110
 - format editor... 109
 - format errors... 118
 - insert tokens... 114
 - transmit leading zeroes... 117
- Print calibration report... 45
- Print format editor... 109
- Print format errors... 118
- Print formats
 - default... 131
- Printed reports... 107

Q

- Quick code parameter entry... 23
- Quick code table... 23

R

- R-Disp commands... 89
- Remote inputs... 145
- Remote outputs... 145
- Routine maintenance... 12
- RS422 module installation... 95
- RS485 module installation... 95

S

- Scale menu... 46, 136
 - AZT... 49
 - division... 47
 - filter... 50
 - ranges... 51, 53
 - stable... 49
 - units... 48
- Scale menu structure... 136
- Seal... 26
- Sense jumpers... 144
- Setup menu... 39
- Setup menu password... 39
- Site ID... 26
- SMA Protocol... 82
 - Level 1 and 2 Commands... 82

- Span calibration... 42
- Stability... 49
- Stainless steel
 - outline dimensions... 147
- Stainless steel enclosure assembly... 139
- Stainless steel enclosure parts kits... 140
- String index/character data entry... 18
- STVS voltage suppressor... 146
- Switch settings... 144
- System block diagram... 143
- System menu... 55
 - archive... 62
 - buttons... 58
 - config... 62
 - display... 57
 - display values... 58
 - password... 64
 - serial... 63
 - site... 57
 - tare... 61
 - update... 63
 - Z-lock... 64
- System menu structure... 137

T

- Tare... 61
- Technical illustrations... 139
- Test inputs... 36
- Time... 25
- Torque specifications... 10
- Transmit leading zeroes... 117
- TSAT token... 126

U

- USB device option module installation... 96
- User level menus... 24
- User menu... 24
- User menu structure... 133

W

- width syntax... 119
- WSTAT token... 126

Z

Zero calibration... 41

ZM305 main PC board... 144

Avery Weigh-Tronix



Avery Weigh-Tronix USA

1000 Armstrong Dr.

Fairmont MN 56031 USA

Tel:507-238-4461

Fax:507-238-4195

Email: usinfo@awtxglobal.com

www.averyweigh-tronix.com

Avery Weigh-Tronix UK

Foundry Lane,

Smethwick, West Midlands,

England B66 2LP

Tel:+44 (0) 8453 66 77 88

Fax:+44 (0)121 224 8183

Email: info@awtxglobal.com

www.averyweigh-tronix.com